



Transport
Canada
Motor Vehicle
Safety

Transports
Canada
Sécurité des
véhicules
automobiles

TECHNICAL STANDARDS DOCUMENT No. 108, Revision 5R

Lamps, Reflective Devices, and Associated Equipment

The text of this document is based on Federal Motor Vehicle Safety Standard No. 108, *Lamps, Reflective Devices, and Associated Equipment*, as published in the U.S. *Code of Federal Regulations*, Title 49, Part 571, revised as of April 27, 2011.

Publication Date:	July 9, 2011
Effective Date:	July 9, 2011
Mandatory Compliance Date:	January 9, 2012

(Ce document est aussi disponible en français)

Introduction

As defined by section 12 of the *Motor Vehicle Safety Act*, a Technical Standards Document (TSD) is a document that reproduces an enactment of a foreign government (e.g. a Federal Motor Vehicle Safety Standard issued by the U.S. National Highway Traffic Safety Administration). According to the Act, the *Motor Vehicle Safety Regulations* may alter or override some provisions contained in a TSD or specify additional requirements; consequently, it is advisable to read a TSD in conjunction with the Act and sections 108 and 108.1 of the Regulations. As a guide, where modifications have been made, they are indicated in the margin of the TSD within parentheses () when they refer to section 108 and within braces { } when they refer to section 108.1.

TSDs are revised from time to time in order to incorporate amendments made to the reference document, at which time a Notice of Revision is published in the *Canada Gazette*, Part I. All TSDs are assigned a revision number, with “Revision 0” designating the original version.

Identification of Changes

In order to facilitate the incorporation of a TSD, certain non-technical changes may be made to the foreign enactment. These may include the deletion of words, phrases, figures, or sections that do not apply under the Act or Regulations, the conversion of imperial to metric units, the deletion of superseded dates, and minor changes of an editorial nature. Additions are underlined, and provisions that do not apply are ~~stroked through~~. Where an entire section has been deleted, it is replaced by: “[CONTENT DELETED]”. Changes are also made where there is a reporting requirement or reference in the foreign enactment that does not apply in Canada. For example, the name and address of the U.S. Department of Transportation are replaced by those of the Department of Transport, Infrastructure and Communities.

Effective Date and Mandatory Compliance Date

Compliance with the requirements of a TSD that is being introduced for the first time is not mandatory until six months after publication in the *Canada Gazette*, Part II, of the Regulations that incorporate the TSD. In the case of a revision, compliance becomes mandatory six months after publication of the Notice of revision in the *Canada Gazette*, Part I, as long as the requirements of the previous version continue to be met. Voluntary compliance is permitted as of the Effective Date of the TSD.

Official Version of Technical Standards Documents

The PDF version is a replica of the TSD as published by the Department and is to be used for the purposes of legal interpretation and application.

Table of Contents

Introduction	i
S1. Scope	1
S2. Purpose	1
S3. Application	1
S4. Definitions	1
S5. Requirements	3
S5.1 Required motor vehicle lighting equipment	3
S5.2 Other requirements	8
S5.3 Location of required equipment	8
S5.4 Equipment combinations	11
S5.5 Special wiring requirements	11
S5.6 [Reserved]	14
S5.7 Conspicuity systems	14
S5.8 Replacement equipment	18
S6. Subreferenced SAE standards and recommended practices	18
S7. Headlighting requirements	18
S7.1 [Untitled]	18
S7.2 [Untitled]	18
S7.3 Sealed beam headlighting system	19
S7.4 Integral beam headlighting system	23
S7.5 Replaceable bulb headlamp system	26
S7.6 Combination headlighting system	29
S7.7 Replaceable light sources	30
S7.8 Aimability performance requirements	32
S7.9 Motorcycles	41
S8. Tests and procedures for integral beam and replaceable bulb headlighting systems	43
S8.1 Photometry	43
S8.2 Abrasion	44
S8.3 Chemical resistance	44
S8.4 Corrosion	45
S8.5 Dust	46
S8.6 Temperature and internal heat test	46
S8.7 Humidity	47

S8.8 Vibration _____	48
S8.9 Sealing _____	48
S8.10 Chemical and corrosion resistance of reflectors of replaceable lens headlamps _____	48
S9. Deflection test for replaceable light sources _____	49
S10. Simultaneous aim photometry tests _____	50
S11. Photometric test _____	50
S12. Headlamp Concealment Devices _____	51

Table of Figures

Figure 1A: Required Percentages of Minimum Candlepower of Figure 1B _____	52
Figure 1B: Minimum and Maximum Allowable Candlepower Values _____	52
Figure 1C: Sum of the Percentages of Grouped Minimum Candlepower _____	53
Figure 2: Minimum Luminous Intensity Requirements for Backup Lamps _____	53
Figure 4-1: Dimensional Specifications for Location of Aiming Pads on Replaceable Bulb Headlamp Units _____	54
Figure 4-2: Detailed Example of Aiming Pad _____	55
Figure 4-3: Dimensional Specifications for Location of Aiming Pads on Replaceable Bulb Units _____	56
Figure 4-4: Dimensional Specifications for Location of Aiming Pads on Replaceable Bulb Units _____	57
Figure 5: Abrasion Test Fixture _____	58
Figure 6: Thermal Cycle Profile _____	59
Figure 7: Dirt/Ambient Test Setup _____	60
Figure 8: Bulb Deflection Test _____	61
Figure 9: Temperature-Humidity Environmental Test Profile _____	62
Figure 10: Photometric Requirements for Center High-Mounted Stop Lamps _____	63
Figure 15-1: Photometric Test Point Values for Mechanical Aim Headlighting Systems ____	65
Figure 15-2: Photometric Test Point Values for Visual/Optical Aim Headlighting Systems	66
Figure 17-1: Photometric Test Point Values for Mechanical Aim Headlighting Systems ____	67
Figure 17-2: Photometric Test Point Values for Visual/Optical Aim Headlighting Systems	68
Figure 19: Visibility of Installed Lighting Devices _____	69
Figure 20: Visibility of Installed Lighting Devices _____	70
Figure 25: Pressure Chamber _____	71
Figure 26: Table for Determining the Photometric Requirements of Replaceable Bulb Headlamp Systems _____	72
Figure 27-1: Photometric Test Point Values for Mechanical Aim Headlighting Systems _	73

Figure 27-2: Photometric Test Point Values for Visual/Optical Aim Headlighting Systems	74
Figure 28-1: Photometric Test Point Values for Mechanical Aim Headlighting Systems	75
Figure 28-2: Photometric Test Point Values for Visual/Optical Aim Headlighting Systems	76
Figure 29: Minimum Photometric Performance of Retroreflective Sheeting	77
Figure 30-1: Trailer Conspicuity Treatment Example	78
Figure 30-2: Trailer Conspicuity Treatment Example	79
Figure 30-3: Trailer Conspicuity Treatment Example	80
Figure 30-4: Trailer Conspicuity Treatment Example	81
Figure 31: Tractor Conspicuity Treatment Example	82
Figure 32: Motorcycle and Limited-Speed Motorcycle Motor-Driven Cycle Headlamp Photometric Requirements	83

List of Tables

Table I: Required Motor Vehicle Lighting Equipment other than Headlamps	85
Table II: Location of Required Equipment	86
Table II (Cont'd): Location of Required Equipment	88
Table III: Required Motor Vehicle Lighting Equipment	89
Table IV: Location of Required Equipment	90
Table IV (Cont'd): Location of Required Equipment	91

S1. Scope

This Technical Standards Document (TSD) standard specifies requirements for ~~original and replacement~~ lamps, reflective devices, and associated equipment fitted to new motor vehicles.

S2. Purpose

The purpose of this TSD standard is to reduce traffic accidents, deaths, and injuries resulting from traffic accidents by providing adequate illumination of the roadway and by enhancing the conspicuity of motor vehicles on public roads so that their presence is perceived and their signals understood, both in daylight and in darkness or other conditions of reduced visibility.

(1) S3. Application

[CONTENT DELETED] For applicability, see Schedule III and section 108 of Schedule IV to the [Motor Vehicle Safety Regulations \(MVSR\)](#).

S4. Definitions

Aiming reference plane means a plane which is perpendicular to the longitudinal axis of the vehicle and tangent to the forward-most aiming pad on the headlamp. (*Plan d'orientation repère*)

Axis of reference means the characteristic axis of the lamp for use as the direction of reference ($H = 0^\circ$, $V = 0^\circ$) for angles of field for photometric measurements and for installing the lamp on the vehicle. (*Axe de référence*)

Beam contributor means an indivisible optical assembly, including a lens, reflector, and light source, that is part of an integral beam headlighting system and contributes only a portion of a headlamp beam. (*Projecteur contribuant*)

Cargo lamp is a lamp that is mounted on a multipurpose passenger vehicle, truck, or bus for the purpose of providing illumination to load or unload cargo. (*Feu de déchargement*)

Cutoff means a generally horizontal, visual/optical aiming cue in the lower beam that marks a separation between areas of higher and lower luminance. (*Coupure*)

Direct reading indicator means a device that is mounted in its entirety on a headlamp or headlamp aiming or headlamp mounting equipment, is part of a VHAD, and provides information about headlamp aim in an analog or digital format. (*Indicateur à lecture directe*)

Effective light-emitting surface means that portion of a lamp that directs light to the photometric test pattern, and does not include transparent lenses, mounting hole bosses, the reflex reflector area, beads, or rims that may glow or produce small areas of increased intensity as a result of uncontrolled light from an area of 0.5-degree radius around a test point. (*Surface de sortie efficace de la lumière*)

Effective projected luminous lens area means the area of the orthogonal projection of the effective light-emitting surface of a lamp on a plane perpendicular to a defined direction relative to the axis of reference. Unless otherwise specified, the direction is coincident with the axis of reference. (*Surface lumineuse efficace projetée d'une lentille*)

Filament means that part of the light source or light emitting element(s), such as a resistive element, the excited portion of a specific mixture of gases under pressure, or any part of other energy conversion sources, that generates radiant energy which can be seen. (*Filament*)

* ~~Flash means a cycle of activation and deactivation of a lamp by automatic means continuing until stopped either automatically or manually.~~ (*Clignotement*)

Fully opened means the position of the headlamp concealment device in which the headlamp is in the design open operating position. (*Entièrement ouvert*)

Headlamp concealment device means a device, with its operating system and components, that provides concealment of the headlamp when it is not in use, including a movable headlamp cover and a headlamp that displaces for concealment purposes. (*Dispositif de dissimulation de projecteur*)

Headlamp test fixture means a device designed to support a headlamp or headlamp assembly in the test position specified in the laboratory tests and whose mounting hardware and components are those necessary to operate the headlamp as installed in a motor vehicle. (*Appareil d'essai de projecteur*)

Integral beam headlamp means a headlamp (other than a standardized sealed beam headlamp designed to conform to paragraph S7.3 or a replaceable bulb headlamp designed to conform to paragraph S7.5) comprising an integral and indivisible optical assembly including lens, reflector, and light source, except that a headlamp conforming to paragraph S7.8.5.2 or paragraph S7.8.5.3 may have a lens designed to be replaceable. (*Projecteur à faisceau intégré*)

Multiple compartment lamp means a device which gives its indication by two or more separately lighted areas which are joined by one or more common parts, such as a housing or lens. (*Feu à compartiments multiples*)

Multiple lamp arrangement means an array of two or more separate lamps on each side of the vehicle which operate together to give a signal. (*Arrangement à feux multiples*)

Remote reading indicator means a device that is not mounted in its entirety on a headlamp or headlamp aiming or headlamp mounting equipment, but otherwise meets the definition of a direct reading indicator. (*Téléindicateur*)

Replaceable bulb headlamp means a headlamp comprising a bonded lens and reflector assembly and one or two replaceable headlamp light sources, except that a headlamp

* Please see subsection 2(1) of the [Motor Vehicle Safety Regulations](#) for the applicable definition.

conforming to paragraph S7.8.5.2 or paragraph S7.8.5.3 may have a lens designed to be replaceable. (*Projecteur à ampoule remplaçable*)

Replaceable light source means an assembly of a capsule, base, and terminals that is designed to conform to the specifications specified or provided in accordance with section 108 of the MVSR requirements of Appendix A or Appendix B of part 564 Replaceable Light Source Information of this Chapter. (*Source lumineuse remplaçable*)

Vehicle headlamp aiming device or **VHAD** means motor vehicle equipment, installed either on a vehicle or headlamp, which is used for determining the horizontal or vertical aim, or both the vertical and horizontal aim of the headlamp. (*Dispositif d'orientation intégré du véhicule* ou *DOIV*)

Visually/optically aimable headlamp means a headlamp which is designed to be visually/optically aimable in accordance with the requirements of paragraph S7.8.5.3 of this TSD standard. (*Projecteur orientable visuellement/optiquement*)

S5. Requirements

(8) S5.1 Required motor vehicle lighting equipment

- (2) **S5.1.1** Except as provided in succeeding paragraphs of this S5.1.1, each vehicle shall be equipped with at least the number of lamps, reflective devices, and associated equipment specified in Tables I and III and S7, as applicable. Required equipment shall be designed to conform to the SAE Standards or Recommended Practices referenced in those tables. Table I applies to multipurpose passenger vehicles, trucks, trailers, and buses 2.05 m or more (80 or more inches) in overall width. Table III applies to passenger cars and motorcycles and to multipurpose passenger vehicles, trucks, trailers, and buses less than 2.05 m (80 inches) in overall width.

S5.1.1.1 A truck tractor need not be equipped with turn signal lamps mounted on the rear if the turn signal lamps at or near the front are so constructed (double-faced) and so located that they meet the requirements for double-faced turn signals specified in SAE Standard J588e, *Turn Signal Lamps*, September 1970.

S5.1.1.2 A truck tractor need not be equipped with any rear side marker devices, rear clearance lamps, and rear identification lamps.

S5.1.1.3 Intermediate side marker devices are not required on vehicles less than 9.1 m (30 feet) in overall length.

- (10) **S5.1.1.4** Reflective material conforming to Federal Specification L-S-300, *Sheeting and Tape, Reflective; Non-exposed Lens, Adhesive Backing*, September 7, 1965, may be used for side reflex reflectors if this material, as used on the vehicle, meets the performance standards in either Table I or Table IA of SAE Standard J594f, *Reflex Reflectors*, January 1977.

S5.1.1.5 The turn signal operating unit on each passenger car and multipurpose passenger vehicle, truck, and bus less than 2.05 m (80 inches) in overall width shall be self-canceling by steering wheel rotation and capable of cancellation by a manually operated control.

S5.1.1.6 Instead of the photometric values specified in Table 1 of SAE Standards J222 December 1970 or J585e September 1977, a parking lamp or tail lamp, respectively, shall meet the minimum percentage specified in Figure 1A of the corresponding minimum allowable value specified in Figure 1B. The maximum candlepower output of a parking lamp shall not exceed that prescribed in Figure 1B, or of a tail lamp that prescribed in Figure 1B at H or above. If the sum of the percentages of the minimum candlepower measured at the test points is not less than that specified for each group listed in Figure 1C, a parking lamp or tail lamp is not required to meet the minimum photometric value at each test point specified in SAE Standards J222 or J585e, respectively.

S5.1.1.7 A motorcycle turn signal lamp need meet only one-half of the minimum photometric values specified in Table 1 and Table 3 of SAE J588 NOV84, *Turn Signal Lamps*.

S5.1.1.8 For each motor vehicle less than 9.1 m (30 feet) in overall length, the photometric minimum candlepower requirements for side marker lamps specified in SAE Standard J592e, *Clearance, Side Marker, and Identification Lamps*, July 1972, may be met for all inboard test points at a distance of 4.6 m (15 feet) from the vehicle and on a vertical plane that is perpendicular to the longitudinal axis of the vehicle and located midway between the front and rear side marker lamps.

S5.1.1.9 A boat trailer whose overall width is 2.05 m (80 inches) or more need not be equipped with both front and rear clearance lamps, provided an amber (to front) and red (to rear) clearance lamp is located at or near the midpoint on each side so as to indicate its extreme width.

S5.1.1.10 Multiple license plate lamps and backup lamps may be used to fulfill the requirements of the SAE Standards applicable to such lamps referenced in Tables I and III.

S5.1.1.11 A stop lamp that is not optically combined, as defined by SAE Information Report J387, *Terminology—Motor Vehicle Lighting*, NOV87, with a turn signal lamp shall remain activated when the turn signal lamp is flashing.

- (11) ~~**S5.1.1.12** On a motor vehicle, except a passenger car, whose overall width is 2,032 mm (80 inches) or more, measurements of the effective projected luminous lens area, and of the photometries of a multiple compartment stop lamp and a multiple compartment turn signal lamp, shall be made for the entire lamp and not for the individual compartments.~~

S5.1.1.13 Each passenger car and each multipurpose passenger vehicle, truck, and bus of less than 2.05 m (80 inches) overall width shall be equipped with a turn signal operating unit designed to complete a durability test of 100,000 cycles.

S5.1.1.14 A trailer that is less than 760 mm (30 inches) in overall width may be equipped with only one tail lamp, stop lamp, and rear reflex reflector, which shall be located at or near its vertical centerline.

S5.1.1.15 A trailer that is less than 1.8 m (6 feet) in overall length, including the trailer tongue, need not be equipped with front side marker lamps and front side reflex reflectors.

S5.1.1.16 A lamp designed to use a type of bulb that has not been assigned a mean spherical candlepower rating by its manufacturer and is not listed in SAE Standard J573d, *Lamp Bulbs*

and Sealed Units, December 1968, shall meet the applicable requirements of this TSD standard when used with any bulb of the type specified by the lamp manufacturer, operated at the bulb's design voltage. A lamp that contains a sealed-in bulb shall meet these requirements with the bulb operated at the bulb's design voltage.

- (6) **S5.1.1.17** Except for a lamp having a sealed-in bulb, a lamp shall meet the applicable requirements of this TSD standard when tested with a bulb whose filament is positioned within ± 0.25 mm (± 0.010 inch) of the nominal design position specified in SAE Standard J573d, *Lamp Bulbs and Sealed Units*, December 1968, or specified by the bulb manufacturer.

S5.1.1.18 A backup lamp is not required to meet the minimum photometric values at each test point specified in Table I of SAE Standard J593c, *Backup Lamps*, February 1968, if the sum of the candlepower measured at the test points within each group listed in Figure 2 is not less than the group totals specified in that figure.

S5.1.1.19 Each variable load turn signal flasher shall comply with the voltage drop and durability requirements of SAE Standard J590b, *Turn Signal Flashers*, October 1965, with the maximum design load connected, and shall comply with starting time, flash rate, and percent current "on" time requirements of J590b, both with the minimum and with the maximum design load connected.

S5.1.1.20 The lowest voltage drop for turn signal flashers and hazard warning signal flashers measured between the input and load terminals shall not exceed 0.8 volt.

- (11) **S5.1.1.21** ~~A motor-driven cycle whose speed attainable in 1 mile is 30 mph or less need not be equipped with turn signal lamps.~~

- (7) **S5.1.1.22** A limited-speed motorcycle ~~motor-driven cycle~~ whose speed attainable in 1.6 km (1 mile) is 50 km/h (30 mph) or less may be equipped with a stop lamp whose effective projected luminous lens area is not less than 23 cm² (3.5 square inches) and whose photometric output for the groups of test points specified in Figure 1 is at least one-half of the minimum values set forth in that figure.

S5.1.1.23 [Reserved]

S5.1.1.24 [Reserved]

S5.1.1.25 Each turn signal lamp on a motorcycle shall have an effective projected luminous lens area of not less than 2,258 mm² (3.5 square inches).

S5.1.1.26 On a motor vehicle whose overall width is less than 2.05 m (80 inches):

- (a) The effective projected luminous lens area of a single compartment stop lamp, and a single compartment rear turn signal lamp, shall be not less than 50 cm² (7.75 square inches).
- (b) If a multiple compartment lamp or multiple lamps are used to meet the photometric requirements for stop lamps and rear turn signal lamps, the effective projected luminous lens area of each compartment or lamp shall be at least 22 cm², provided the combined area is at least 50 cm² (7.75 square inches).

S5.1.1.27

- (a) Except as provided in paragraph (b) of this section, each passenger car ~~manufactured on or after September 1, 1985~~, and each multipurpose passenger vehicle, truck, and bus whose overall width is less than 2.05 m (80 inches) and whose GVWR is 4,536 kg (10,000 pounds) or less ~~manufactured on or after September 1, 1993~~, shall be equipped with a high-mounted stop lamp which:
- (1) Shall have an effective projected luminous lens area not less than 2,903 mm² (4.5 square inches).
 - (2) Shall meet the visibility requirements specified in S5.3.2(c).
 - (3) Shall have the minimum photometric values in the amount and location listed in Figure 10.
 - (4) Need not meet the requirements of paragraphs 3.1.6 Moisture Test, 3.1.7 Dust Test, and 3.1.8 Corrosion Test of SAE Recommended Practice J186a, *Supplemental High-Mounted Stop and Rear Turn Signal Lamps*, September 1977, if it is mounted inside the vehicle.
 - (5) Shall provide access for convenient replacement of the bulb without the use of special tools.
- (b) Each multipurpose passenger vehicle, truck and bus whose overall width is less than 2.05 m (80 inches), whose GVWR is 4,536 kg (10,000 pounds) or less, whose vertical centerline, when the vehicle is viewed from the rear, is not located on a fixed body panel but separates one or two movable body sections, such as doors, which lacks sufficient space to install a single high-mounted stop lamp on the centerline above such body sections, ~~and which is manufactured on or after September 1, 1993~~, shall have two high-mounted stop lamps which:
- (1) Are identical in size and shape and have an effective projected luminous lens area not less than 1,452 mm² (2.25 square inches) each.
 - (2) Shall meet the visibility requirements specified in S5.3.2 (d).
 - (3) Together have the minimum photometric values specified in paragraph (a)(3) of this S5.1.1.27.
 - (4) Shall provide access for convenient replacement of the bulbs without special tools.

S5.1.1.28 [Reserved]

S5.1.1.29 A trailer equipped with a conspicuity treatment in conformance with paragraph S5.7 of this ~~TSD standard~~ need not be equipped with the reflex reflectors required by Table I of this ~~TSD standard~~ if the conspicuity material is placed at the locations of the reflex reflectors required by Table I.

- {1} **S5.1.2** Plastic materials used for optical parts such as lenses and reflectors shall conform to SAE Recommended Practice J576 JUL91, except that:

- (a) Plastic lenses (other than those incorporating reflex reflectors) used for inner lenses or those covered by another material and not exposed directly to sunlight shall meet the requirements of paragraphs 3.3 and 4.2 of SAE J576 JUL91 when covered by the outer lens or other material;
 - (b) After the outdoor exposure test, the haze and loss of surface luster of plastic materials (other than those incorporating reflex reflectors) used for outer lenses shall not be greater than 30 percent haze as measured by ASTM D 1003-92, *Haze and Luminous Transmittance of Transparent Plastic*;
 - (c) After the outdoor exposure test, plastic materials used for reflex reflectors and for lenses used in front of reflex reflectors shall not show surface deterioration, crazing, dimensional changes, color bleeding, delamination, loss of surface luster, or haze that exceeds 7 percent as measured under ASTM D 1003-92.
 - (d) The thickness of the test specimens specified in paragraph 3.2.2 of SAE J576 JUL91 may vary by as much as ± 0.25 mm.
 - (e) After exposure to the heat test as specified in subparagraph (f) of this paragraph, and after cooling to room ambient temperature, a test specimen shall show no change in shape and general appearance discernible to the naked eye when compared with an unexposed specimen. The trichromatic coefficients of the samples shall conform to the requirements of SAE Standard J578c, *Color Specification for Electric Signal Lighting Devices*, February 1977.
 - (f) Two samples of each thickness of each plastic material are used in the heat test. Each sample is supported at the bottom, with at least 51 mm of the sample above the support, in the vertical position in such a manner that, on each side, the minimum uninterrupted area of exposed surface is not less than 3,225 sq. mm. The samples are placed for two hours in a circulating air oven at 79 ± 3 degrees C.
 - (g) All outdoor exposure tests shall be 3 years in duration, whether the material is exposed or protected. Accelerated weathering procedures are not permitted.
- (65) **S5.1.3** No additional lamp, reflective device, or other motor vehicle equipment shall be installed that impairs the effectiveness of lighting equipment required by this TSD standard.
- (13) **S5.1.4** Each school bus other than a multifunction school activity bus shall be equipped with a system of either:
- (a) Four red signal lamps designed to conform to SAE Standard J887, *School Bus Red Signal Lamps*, July 1964, and installed in accordance with that standard; or
 - (b) Four red signal lamps designed to conform to SAE Standard J887, *School Bus Red Signal Lamps*, July 1964, and four amber signal lamps designed to conform to that standard, except for their color and except that their candlepower shall be at least 2.5 times that specified for red signal lamps. Both red and amber lamps shall be installed in accordance with SAE Standard J887, except that:

- (i) Each amber signal lamp shall be located near each red signal lamp, at the same level, but closer to the vertical centerline of the bus; and
- (ii) The system shall be wired so that the amber signal lamps are activated only by manual or foot operation, and if activated are automatically deactivated, and the red signal lamps automatically activated when the bus entrance door is opened.

S5.1.5 The color in all lamps, reflective devices, and associated equipment to which this ~~TSD standard~~ applies shall comply with SAE Standard J578c, *Color Specification for Electric Signal Lighting Devices*, February 1977.

S5.2 Other requirements

S5.2.1 The words “it is recommended that”, “recommendations”, or “should be” appearing in any SAE Standard or Recommended Practice referenced or subreferenced in this ~~TSD standard~~ shall be read as setting forth mandatory requirements, except that the aiming pads on the lens face and the black area surrounding the signal lamp recommended in SAE Standard J887, *School Bus Red Signal Lamps*, July 1964, are not required.

S5.2.2 The words “Type 1 (5¾)”, “Type 2 (5¾)”, “Type 2 (7)”, “Type 1A”, “Type 2A”, and “Type 2B” appearing in any SAE Standard or Recommended Practice reference or subreferenced in this ~~TSD standard~~ shall also be read as setting forth requirements respectively for the following types of headlamps: 1C1, 2C1, 2D1, 1A1, 2A1, and 2B1.

S5.3 Location of required equipment

(14)
(14.1)
(15)
(65)

Except as provided in paragraphs S5.3.2, S5.7, and S7, each lamp, reflective device, and item of associated equipment shall be securely mounted on a rigid part of the vehicle other than glazing that is not designed to be removed except for repair, in accordance with the requirements of Table I and Table III, as applicable, and in the location specified in Table II [multipurpose passenger vehicles, trucks, trailers, and buses 2.05 m or more (80 or more inches) in overall width] or Table IV [all passenger cars and motorcycles, and multipurpose passenger vehicles, trucks, trailers, and buses less than 2.05 m (80 inches) in overall width], as applicable.

S5.3.1 [Reserved]

[In accordance with the Notice that was published in the *Canada Gazette*, Part I, on June 9, 2007, see S5.3.]

S5.3.1.1 [Reserved]

[In accordance with the Notice that was published in the *Canada Gazette*, Part I, on June 9, 2007, see S5.3.2.]

S5.3.1.1.1 [Reserved]

S5.3.1.2 On a truck tractor, the red rear reflex reflectors may be mounted on the back of the cab at a minimum height not less than 100 mm (4 inches) above the height of the rear tires.

S5.3.1.3 On a trailer, the amber front side reflex reflectors and amber front side marker lamps may be located as far forward as practicable, exclusive of the trailer tongue.

S5.3.1.4 When the rear identification lamps are mounted at the extreme height of a vehicle, rear clearance lamps need not meet the requirement of Table II that they be located as close as practicable to the top of the vehicle.

S5.3.1.5 [Reserved]

S5.3.1.6 On a truck tractor, clearance lamps mounted on the cab may be located to indicate the width of the cab, rather than the overall width of the vehicle.

S5.3.1.7 On a motor vehicle on which the front turn signal lamp is less than 100 mm from the lighted edge of a lower beam headlamp, as measured from the optical center of the turn signal lamp, the multiplier applied to obtain the required minimum luminous intensities shall be 2.5.

S5.3.1.8

- (a) Each high-mounted stop lamp installed in or on a vehicle subject to S5.1.1.27(a) shall be located as follows:
 - (1) With its center at any place on the vertical centerline of the vehicle, including the glazing, as the vehicle is viewed from the rear.
 - (2) If the lamp is mounted below the rear window, no portion of the lens shall be lower than 153 mm (6 inches) below the rear window on convertibles, or 77 mm (3 inches) on other passenger cars.
 - (3) If the lamp is mounted inside the vehicle, means shall be provided to minimize reflections from the light of the lamp upon the rear window glazing that might be visible to the driver when viewed directly, or indirectly in the rearview mirror.
- (b) The high-mounted stop lamps installed in or on a vehicle subject to S5.1.1.27(b) shall be located at the same height, with one vertical edge of each lamp on the vertical edge of the body section nearest the vertical centerline.

S5.3.2 Except as provided in S5.3.2.1 through S5.3.2.4 and in paragraphs S5.7 and S7, each vehicle must conform to the following requirements:

- (a) Each lamp and reflective device must be installed in a location where it complies with all applicable photometric requirements and visibility requirements, with all obstructions (e.g., mirrors, snow plows, wrecker booms, backhoes, and winches) installed on the vehicle.
- (b) A manufacturer must certify compliance of each lamp to one of the following visibility requirement options, and it may not thereafter choose a different option for that vehicle:
 - (1) When a vehicle is equipped with any lamp listed in Figure 19 of this TSD standard, each such lamp must provide not less than 12.5 cm² of unobstructed

effective projected luminous lens area in any direction throughout the pattern defined by the corner points specified in Figure 19 for each such lamp; or

- (2) When a vehicle is equipped with any lamp listed in Figure 20 of this TSD standard, each such lamp must provide a luminous intensity not less than that specified in Figure 20 in any direction throughout the pattern defined by the corner points specified in Figure 20 for each such lamp. The luminous intensity must be measured in accordance with the photometry test requirements of the applicable SAE Standards and Recommended Practices incorporated by reference or subreference in this TSD standard.
- (c) A high-mounted stop lamp must have a signal visible to the rear through a horizontal angle from 45 degrees to the left to 45 degrees to the right of the longitudinal axis of the vehicle.
- (d) High-mounted stop lamps required to comply with S5.1.1.27(b) must together have a signal to the rear as specified in S5.3.2(c).
- (e) Backup lamps must be mounted on the rear so that the optical center of at least one lamp is visible from any eye point elevation from at least 1,828 mm (6 ft) to 610 mm (2 ft) above the horizontal plane on which the vehicle is standing and from any position in the area rearward of a vertical plane perpendicular to the longitudinal axis of the vehicle 914 mm (3 ft) to the rear of the vehicle and extending 914 mm (3 ft) beyond each side of the vehicle.

S5.3.2.1 Clearance lamps may be located at a location other than on the front and rear, if necessary, to indicate the overall width of a vehicle, or for protection from damage during normal operation of the vehicle, and at such a location that they need not meet the photometric output at any test point that is 45 degrees inboard.

S5.3.2.2 If any required lamp or reflective device is obstructed by motor vehicle equipment (e.g., mirrors, snow plows, wrecker booms, backhoes, winches, etc.) and cannot meet the requirements of S5.3.2, the vehicle must be equipped with an additional lamp or device of the same type which meet all applicable requirements of this TSD standard, including S5.3.2.

S5.3.2.3 For signal lamps and reflective devices mounted less than 750 mm above the road surface, as measured to the lamp axis of reference, the vertical test point angles located below the horizontal plane subject to photometric and visibility requirements of this TSD standard may be reduced to 5 degrees.

S5.3.2.4 As an alternative to S5.3.2(b), each passenger car and motorcycle, and each multipurpose passenger vehicle, truck, trailer, and bus that is of less than 2,032 mm overall width, that is manufactured on or before September 1, 2011, and each multipurpose passenger vehicle, truck, trailer, and bus of 2,032 mm or more overall width that is manufactured on or before September 1, 2014, must have each lamp located so that it meets the visibility requirements specified in any applicable SAE Standard or Recommended Practice.

S5.4 Equipment combinations

Two or more lamps, reflective devices, or items of associated equipment may be combined if the requirements for each lamp, reflective device, and item of associated equipment are met, with the following exceptions:

- (a) No high-mounted stop lamp shall be combined with any other lamp or reflective device, other than ~~with~~ a cargo lamp.
- (b) No high-mounted stop lamp shall be combined optically, as defined by SAE Information Report J387, *Terminology—Motor Vehicle Lighting* NOV87, with any cargo lamp.
- (c) No clearance lamp shall be combined optically, as defined by SAE Information Report J387, *Terminology—Motor Vehicle Lighting* NOV87, with any tail lamp.

S5.5 Special wiring requirements

- (16) **S5.5.1** Each vehicle shall have a means of switching between lower and upper beams that (59) conforms to SAE Recommended Practice J564a, *Headlamp Beam Switching*, April 1964, or to SAE Recommended Practice J565b, *Semi-Automatic Headlamp Beam Switching Devices*, February 1969. Except as provided in S5.5.8, the lower and upper beams shall not be energized simultaneously except momentarily for temporary signalling purposes or during switching between beams.
- (16) **S5.5.2** Each vehicle shall have a means for indicating to the driver when the upper beams of the headlamps are on that conforms to SAE Recommended Practice J564a, April 1964, except that the signal color need not be red.
- (48) **S5.5.3** The tail lamps on each vehicle shall be activated when the headlamps are activated in (50) a steady-burning state, but need not be activated if the headlamps are activated at less than (58) full intensity ~~as permitted by paragraph S5.5.11(a)~~.

S5.5.4 The stop lamps on each vehicle shall be activated upon application of the service brakes. The high-mounted stop lamp on each vehicle shall be activated only upon application of the service brakes.

S5.5.5 The vehicular hazard warning signal operating unit on each vehicle shall operate independently of the ignition or equivalent switch, and when activated, shall cause to flash simultaneously sufficient turn signal lamps to meet, as a minimum, the turn signal lamp photometric requirements of this TSD standard.

S5.5.6 Each vehicle equipped with a turn signal operating unit shall also have an illuminated pilot indicator. Failure of one or more turn signal lamps to operate shall be indicated in accordance with SAE Standard J588e, *Turn Signal Lamps*, September 1970, except when a variable-load turn signal flasher is used on a truck, bus, or multipurpose passenger vehicle 2.05 m or more (80 or more inches) in overall width, on a truck that is capable of accommodating a slide-in camper, or on any vehicle equipped to tow trailers.

- (19) **S5.5.7** On each passenger car and motorcycle, and on each multipurpose passenger vehicle, truck, and bus of less than 2.05 m (80 inches) overall width:
- (a) When the parking lamps are activated, the tail lamps, license plate lamps, and side marker lamps shall also be activated; and
 - (b) When the headlamps are activated in a steady-burning state, the tail lamps, parking lamps, license plate lamps, and side marker lamps shall also be activated.

S5.5.8 On a motor vehicle equipped with a headlighting system designed to conform to the photometric requirements of Figure 15-1 or Figure 15-2, the lamps marked “L” or “LF” may be wired to remain permanently activated when the lamps marked “U” or “UF” are activated. On a motor vehicle equipped with an Integral Beam headlighting system meeting the photometric requirements of paragraph S7.4(a)(1)(ii), the lower beam headlamps shall be wired to remain permanently activated when the upper beam headlamps are activated. On a motor vehicle equipped with a headlighting system designed to conform to the requirements of Figure 17-1 or Figure 17-2, a lower beam light source may be wired to remain activated when an upper beam light source is activated if the lower beam light source contributes to compliance of the headlighting system with the upper beam requirements of Figure 17-1 or Figure 17-2.

- {1} **S5.5.9** Except as provided in section S5.5.8, the wiring harness or connector assembly of each headlamp system shall be designed so that only those light sources intended for meeting lower beam photometrics are energized when the beam selector switch is in the lower beam position, and that only those light sources intended for meeting upper beam photometrics are energized when the beam selector switch is in the upper beam position.

S5.5.10 The wiring requirements for lighting equipment in use are:

- (a) Turn signal lamps, hazard warning signal lamps, and school bus warning lamps shall be wired to flash;
 - (b) Headlamps and side marker lamps may be wired to flash for signaling purposes;
 - (c) A motorcycle headlamp may be wired to allow either its upper beam or its lower beam, but not both, to modulate from a higher intensity to a lower intensity in accordance with section S7.9.4 ~~S5-6~~;
- (60) (d) All other lamps shall be wired to be steady-burning.

- (20) **S5.5.11** [Replaced by subsections 108(44) to (65) of the [MVSR](#).]

- ~~(a) Any pair of lamps on the front of a passenger car, multipurpose passenger vehicle, truck, or bus, whether or not required by this standard, other than parking lamps or fog lamps, may be wired to be automatically activated, as determined by the manufacturer of the vehicle, in a steady burning state as daytime running lamps (DRLs) and to be automatically deactivated when the headlamp control is in any “on” position, and as otherwise determined by the manufacturer of the vehicle, provided that each such lamp:~~

- ~~(1) Has a luminous intensity not less than 500 candela at test point H-V, nor more than 3,000 candela at any location in the beam, when tested in accordance with Section S11 of this standard, unless it is:
 - ~~(i) A lower beam headlamp intended to operate as a DRL at full voltage, or at a voltage lower than used to operate it as a lower beam headlamp; or~~
 - ~~(ii) An upper beam headlamp intended to operate as a DRL, whose luminous intensity at test point H-V is not more than 7,000 candela, and which is mounted not higher than 864 mm above the road surface as measured from the center of the lamp with the vehicle curb weight;~~~~
 - ~~(2) Is permanently marked "DRL" on its lens in letters not less than 3 mm high, unless it is optically combined with a headlamp;~~
 - ~~(3) Is designed to provide the same color as the other lamp in the pair, and that is one of the following colors as defined in SAE Standard J578 MAY88: White, white to yellow, white to selective yellow, selective yellow, or yellow;~~
 - ~~(4) If not optically combined with a turn signal lamp, is located so that the distance from its lighted edge to the optical center of the nearest turn signal lamp is not less than 100 mm, unless:
 - ~~(i) The luminous intensity of the DRL is not more than 2,600 candela at any location in the beam and the turn signal meets the requirements of S5.3.1.7; or~~
 - ~~(ii) (For a passenger car, multipurpose passenger vehicle, truck, or bus that is manufactured before October 1, 1995, and which uses an upper beam headlamp as a DRL as specified in paragraph S5.5.11(a)(1)(ii)) the luminous intensity of the DRL is greater than 2,600 candela at any location in the beam and the turn signal lamp meets the requirements of S5.3.1.7; or~~
 - ~~(iii) The DRL is optically combined with a lower beam headlamp and the turn signal lamp meets the requirements of S5.3.1.7; or~~
 - ~~(iv) The DRL is deactivated when the turn signal or hazard warning signal lamp is activated.~~~~
 - ~~(5) If optically combined with a turn signal lamp, is automatically deactivated as a DRL when the turn signal lamp or hazard warning lamp is activated, and automatically reactivated as a DRL when the turn signal lamp or hazard warning lamp is deactivated.~~
- ~~(b) Any pair of lamps that are not required by this standard and are not optically combined with any lamps that are required by this standard, and which are used as DRLs to fulfill the specifications of S5.5.11(a), shall be mounted at the same height, which shall be not more than 1.067 m above the road surface measured from the center of the lamp on the vehicle at curb weight, and shall be symmetrically disposed about the vertical centerline of the vehicle.~~

S5.6 [Reserved]

(21) S5.7 Conspicuity systems

Each trailer of 2.05 m or more (80 or more inches) overall width, and with a GVWR over 4,536 kg (10,000 pounds), ~~manufactured on or after December 1, 1993~~, except a trailer designed exclusively for living or office use, and each truck tractor ~~manufactured on or after July 1, 1997~~, shall be equipped with either retroreflective sheeting that meets the requirements of S5.7.1, reflex reflectors that meet the requirements of S5.7.2, or a combination of retroreflective sheeting and reflex reflectors that meet the requirement of S5.7.3.

S5.7.1 Retroreflective sheeting. Each trailer or truck tractor to which S5.7 applies that does not conform to S5.7.2 or S5.7.3 shall be equipped with retroreflective sheeting that conforms to the requirements specified in S5.7.1.1 through S5.7.1.5.

S5.7.1.1 Construction. Retroreflective sheeting shall consist of a smooth, flat, transparent exterior film with retroreflective elements embedded or suspended beneath the film so as to form a non-exposed retroreflective optical system.

- (21) **S5.7.1.2 Performance requirements.** Retroreflective sheeting shall meet the requirements
(22) of ASTM D 4956-90, *Standard Specification for Retroreflective Sheeting for Traffic Control*,
(24) *for Type V Sheeting*, except for the photometric requirements, and shall meet the minimum photometric performance requirements specified in Figure 29.

S5.7.1.3 Sheeting pattern, dimensions, and relative coefficients of retroreflection

- (a) Retroreflective sheeting shall be applied in a pattern of alternating white and red color segments to the sides and rear of each trailer, and to the rear of each truck tractor, and in white to the upper rear corners of each trailer and truck tractor, in the locations specified in S5.7.1.4, and Figures 30-1 through 30-4, or Figure 31, as appropriate.
- (b) Except for a segment that is trimmed to clear obstructions, or lengthened to provide red sheeting near red lamps, each white or red segment shall have a length of 300 mm \pm 150 mm.
- (c) Neither white nor red sheeting shall represent more than two thirds of the aggregate of any continuous strip marking the width of a trailer, or any continuous or broken strip marking its length.
- (d) Retroreflective sheeting shall have a width of not less than 50 mm (Grade DOT-C2), 75 mm (Grade DOT-C3), or 100 mm (Grade DOT-C4).
- (e) The coefficients for retroreflection of each segment of red or white sheeting shall be not less than the minimum values specified in Figure 29 of this TSD standard for grades DOT-C2, DOT-C3, and DOT-C4.

(22) **S5.7.1.4 Location**

- (a) Retroreflective sheeting shall be applied to each trailer and truck tractor as specified below, but need not be applied to discontinuous surfaces such as outside ribs, stake post pickets on platform trailers, and external protruding beams, or to items of equipment such as door hinges and lamp bodies on trailers and body joints, stiffening beads, drip rails and rolled surfaces on truck tractors.
- (b) The edge of white sheeting shall not be located closer than 75 mm to the edge of the luminous lens area of any red or amber lamp that is required by this TSD standard.
- (c) The edge of red sheeting shall not be located closer than 75 mm to the edge of the luminous lens area of any amber lamp that is required by this TSD standard.

S5.7.1.4.1 Rear of trailers. Retroreflective sheeting shall be applied to the rear of each trailer as follows, except that Element 2 is not required for container chassis or for platform trailers without bulkheads, and Element 3 is not required for trailers without underride protection devices:

- (21) (a) *Element 1:* A strip of sheeting, as horizontal as practicable, in alternating colors across the full width of the trailer, as close to the extreme edges as practicable, and as close as practicable to not less than 375 mm and not more than 1525 mm above the road surface at the stripe centerline with the trailer at curb mass weight.
- (b) *Element 2:* Two pairs of white strips of sheeting, each pair consisting of strips 300 mm long of grade DOT-C2, DOT-C3, or DOT-C4, applied horizontally and vertically to the right and left upper contours of the body, as viewed from the rear, as close to the top of the trailer and as far apart as practicable. If the perimeter of the body, as viewed from the rear, is other than rectangular, the strips may be applied along the perimeter, as close as practicable to the uppermost and outermost areas of the rear of the body on the left and right sides.
- (23) (c) *Element 3:* A strip of sheeting in alternating colors across the full width of the horizontal member of the rear underride protection device. Grade DOT-C2 material not less than 38 mm wide may be used.

(21) **S5.7.1.4.2 Side of trailers.** Retroreflective sheeting shall be applied to each side of a trailer as follows:

- (a) A strip of sheeting, as horizontal as practicable, in alternating colors, originating and terminating as close to the front and rear as practicable, as close as practicable to not less than 375 mm and not more than 1525 mm above the road surface at the stripe centerline with the trailer at curb mass weight, except that at the location chosen the strip shall not be obscured in whole or in part by other motor vehicle equipment or trailer cargo. The strip need not be continuous as long as not less than half of the length of the trailer is covered and the spaces are distributed as evenly as practicable.
- (b) If necessary to clear rivet heads or other similar obstructions, grade DOT-C2 retroreflective sheeting may be separated into two 25 mm wide strips of the same

length and color, separated by a space of not more than 25 mm, and used in place of the retroreflective sheeting that would otherwise be applied.

S5.7.1.4.3 Rear of truck tractors. Retroreflective sheeting shall be applied to the rear of each truck tractor as follows:

- (a) *Element 1:* Two strips of sheeting in alternating colors, each not less than 600 mm long, located as close as practicable to the edges of the rear fenders, mudflaps, or the mudflap support brackets, to mark the width of the truck tractor. The strips shall be mounted as horizontal as practicable, in a vertical plane facing the rear, on the rear fenders, on the mudflap support brackets, on plates attached to the mudflap support brackets, or on the mudflaps. Strips on mudflaps shall be mounted not lower than 300 mm below the upper horizontal edge of the mudflap. If the vehicle is certified with temporary mudflap support brackets, the strips shall be mounted on the mudflaps or on plates transferable to permanent mudflap support brackets. For a truck tractor without mudflaps, the strips may be mounted outboard of the frame on brackets behind the rear axle or on brackets ahead of the rear axle and above the top of the tires at unladen vehicle height, or they may be mounted directly or indirectly to the back of the cab as close to the outer edges as practicable, above the top of the tires, and not more than 1525 mm above the road surface at unladen vehicle height. If the strips are mounted on the back of the cab, no more than 25 percent of their cumulative area may be obscured by vehicle equipment as determined in a rear orthogonal view.
- (b) *Element 2:* Two pairs of white strips of sheeting, each pair consisting of strips 300 mm long, applied as horizontally and vertically as practicable, to the right and left upper contours of the cab, as close to the top of the cab and as far apart as practicable. No more than 25 percent of their cumulative area may be obscured by vehicle equipment as determined in a rear orthogonal view. If one pair must be relocated to avoid obscuration by vehicle equipment, the other pair may be relocated in order to be mounted symmetrically. If the rear window is so large as to occupy all the practicable space, the material may be attached to the edge of the window itself.

S5.7.1.5 Certification. The letters DOT-C2, DOT-C3, or DOT-C4, as appropriate, constituting a certification that the retroreflective sheeting conforms to the requirements of S5.7.1.2, shall appear at least once on the exposed surface of each white or red segment of retroreflective sheeting, and at least once every 300 mm on retroreflective sheeting that is white only. The characters shall be not less than 3 mm high, and shall be permanently stamped, etched, molded, or printed in indelible ink.

S5.7.2 Reflex reflectors. Each trailer or truck tractor to which S5.7 applies that does not conform to S5.7.1 or S5.7.3 shall be equipped with reflex reflectors in accordance with this section.

S5.7.2.1

- (a) Each reflex reflector shall conform to SAE Standard J594f, *Reflex Reflectors*, January 1977.
- (b) Each red reflex reflector shall also provide, at an observation angle of 0.2 degree, not less than 300 millicandela/lux at any light entrance angle between 30 degrees left and 30 degrees right, including an entrance angle of 0 degree, and not less than 75 millicandela/lux at any light entrance angle between 45 degrees left and 45 degrees right.
- (c) Each white reflex reflector shall also provide at an observation angle of 0.2 degree, not less than 1250 millicandela/lux at any light entrance angle between 30 degrees left and 30 degrees right, including an entrance angle of 0 degree, and not less than 300 millicandela/lux at any light entrance angle between 45 degrees left and 45 degrees right.
- (d) A white reflex reflector complying with S5.7.2.1(a) and (c) when tested in a horizontal orientation may be installed in all orientations specified for rear upper locations in S5.7.1.4.1(b) or S5.7.1.4.3(b) if, when tested in a vertical orientation, it provides at an observation angle of 0.2 degree not less than 1680 millicandelas/lux at a light entrance angle of 0 degree, not less than 1120 millicandelas/lux at any light entrance angle from 10 degrees down to 10 degrees up, and not less than 560 millicandelas/lux at any light entrance angle from 20 degrees right to 20 degrees left.

S5.7.2.2 Reflex reflectors shall be installed and located as specified below:

- (a) In the same locations and in the same length in which retroreflective sheeting is required by S5.7.1.4 to be applied in alternating colors, reflex reflectors shall be installed in a repetitive pattern of two or three white reflex reflectors alternating with two or three red reflex reflectors, with the center of each reflector not more than 100 mm from the center of each adjacent reflector.
- (b) In the same locations and in the same length in which white retroreflective sheeting is required by S5.7.1.4 to be installed, white reflex reflectors shall be installed, with the center of each white reflex reflector not more than 100 mm from the center of each adjacent reflector.

S5.7.2.3 Certification. The exposed surface of each reflex reflector shall be marked with the letters DOT-C, which constitutes a certification that the reflector conforms to all applicable requirements of §571.108 of ~~this part~~ Title 49 of the U.S. *Code of Federal Regulations*. The certification shall be not less than 3 mm high and shall be permanently stamped, etched, molded, or printed in indelible ink.

S5.7.3 Combination of sheeting and reflectors. Each trailer or truck tractor to which S5.7 applies, that does not conform to S5.7.1 or S5.7.2, shall be equipped with retroreflective materials that meet the requirements of S5.7.1, except that reflex reflectors that meet the requirements of S5.7.2.1 and that are installed in accordance with S5.7.2.2 may be used

instead of any corresponding element of retroreflective sheeting located as required by S5.7.1.4.

S5.8 Replacement equipment

[CONTENT DELETED]

S6. Subreferenced SAE standards and recommended practices

- (4) **S6.1** SAE Standards and Recommended Practices subreferenced by the SAE Standards and Recommended Practices included in Tables I and III and paragraphs S5.1.4 and S5.5.1 are those published in the 1970 edition of the SAE Handbook, except that the SAE standard referred to as “J575” is J575e, *Tests for Motor Vehicle Lighting Devices and Components*, August 1970, for stop lamps designed to conform to SAE Standards ~~J586e~~, J586 FEB84 and J1398 MAY85; for tail lamps designed to conform to SAE Standards J585d and J585e; for turn signal lamps designed to conform to SAE Standards J588e, J588 NOV84, and J1395 APR85; and for high-mounted stop lamps designed to conform to SAE Recommended Practice J186a. The reference in J585e to J256 does not apply. For headlamps other than motorcycle headlamps, unless otherwise specified in this TSD standard, the version of SAE Standard J575 is DEC88, and the version of SAE Standard J602 is OCT80. The definition of “optically combined” in SAE Information Report J387, *Terminology—Motor Vehicle Lighting* NOV87, applies to that term as used in ~~J586e and~~ J588e.

S6.2 Requirements of SAE Standards incorporated by reference in this TSD standard, other than J576b and J576c, do not include test for warpage of devices with plastic lenses.

S6.3 The term “functional lighted lens area” in any SAE Standard or Recommended Practice incorporated by reference or by subreference in this TSD standard has the same meaning as the term “effective projected luminous lens area”.

S7. Headlighting requirements

S7.1 [Untitled]

Each passenger car, multipurpose passenger vehicle, truck, and bus ~~manufactured on or after September 1, 1994~~, shall be equipped with a headlighting system designed to conform to the requirements of S7.3, S7.4, S7.5, or S7.6.

S7.2 [Untitled]

- (25) (a) The lens of each ~~original and replacement equipment~~ headlamp, and of each ~~original equipment and replacement equipment~~ beam contributor shall be marked with the symbol “DOT” either horizontally or vertically ~~which shall constitute the certification required by 49 U.S.C. 30115~~.

- (b) The lens of each headlamp and of each beam contributor ~~manufactured on or after December 1, 1989,~~ to which paragraph (a) of this section applies shall be marked with the name and/or trademark ~~registered with the U.S. Patent and Trademark Office~~ of the manufacturer of such headlamp or beam contributor, or its importer, or any manufacturer of a vehicle equipped with such headlamp or beam contributor. Nothing in this paragraph shall be construed to authorize the marking of any such name and/or trademark by one who is not the owner, unless the owner has consented to it.
- (c) Each headlamp and beam contributor to which paragraph (a) of this section applies shall be marked with its voltage and with its part or trade number.
- (d) Unless stated otherwise, a tolerance of ± 0.25 degree is permitted during photometric performance tests for any headlamp or beam contributor, and the test points 10U-90U shall be measured from the normally exposed surface of the lens face. The term “aiming plane” means “aiming reference plane” or an appropriate vertical plane defined by the manufacturer as required in S7.7.1.
- (e) [CONTENT DELETED]

(31) **S7.3 Sealed beam headlighting system**

A sealed beam headlighting system shall be designed to meet the requirements of one of the following subparagraphs of S7.3.2 through S7.3.9. In references to Figures in SAE J1383 APR85 for headlamp dimensional requirements, only those dimensions marked “I” for interchangeability are applicable.

S7.3.1 The lens of each sealed beam headlamp designed to conform to S7.3.2 through S7.3.6 shall be marked according to paragraph 5.4.3 through 5.4.5 of SAE Standard J1383 APR85 *Performance Requirements for Motor Vehicle Headlamps*.

S7.3.2 Type A headlighting system. A Type A headlighting system consists of two Type 1A1 and two Type 2A1 headlamps and associated hardware, which are designed to conform to the following requirements:

- (a) SAE Standard J1383 APR85 *Performance Requirements for Motor Vehicle Headlamps*, with the following exceptions:
 - (1) Paragraphs 1, 2.1.2, 2.8.2, 3, 4.1.1, 4.1.2, 4.1.3, 4.4, 4.6, 4.8 through 4.18, 5.1.1, 5.1.3, 5.1.5, 5.1.7 through 5.1.16, 5.2.2, 5.3.5, 5.4.1, 5.4.2, and 6 through 6.4 do not apply.
 - (2) In paragraph 5.3.2, the words “and retaining rings” are omitted.
 - (3) In paragraphs 4.5.2 and 5.1.6, the words “Figure 28-1 or 28-2 of Motor Vehicle Safety Standard No. 108” are substituted for “Table 3”.
- (b) SAE Standard J580 DEC86 *Sealed Beam Headlamp Assembly* (except paragraphs 3, 4.1.1, 5.1.1.1, 5.1.2.3, and the second sentence of 5.1.6): in 5.2.1, delete the words “and retaining rings.” The correct reference is SAE J1383 Figures 6, 9, 12, and 14.

- (c) After a vibration test conducted in accordance with paragraph S8.8, there shall be no evidence of loose or broken parts, other than filaments, visible without magnification.
- (d) The maximum wattage at 12.8 V (design voltage): Single filament headlamp, 55 watts on the upper beam; dual filament headlamp, 43 watts on the upper beam and 65 watts on the lower beam.

S7.3.3 Type B headlighting system. A Type B headlighting system consists of two Type 2B1 headlamps and associated hardware, which are designed to conform to the following requirements:

- (a) The requirements of paragraphs S7.3.2 (a) through (c), except that the words “Figure 27-1 or Figure 27-2” are substituted for “Table 3” in paragraph S7.3.2(a)(3).
- (b) The maximum wattage at 12.8 V (design voltage): 70 watts on the upper beam and 60 watts on the lower beam.

S7.3.4 Type C headlighting system. A Type C headlighting system consists of two Type 1C1 and two Type 2C1 headlamps and associated hardware, which are designed to conform to the requirements of paragraphs S7.3.2(a) through (d), except that the words “Figure 28-1 or Figure 28-2” are substituted for “Table 3” in paragraph S7.3.2(a)(3).

S7.3.5 Type D headlighting system

- (a) A Type D headlighting system consists of two Type 2D1 headlamps and associated hardware, which are designed to conform to the requirements of paragraphs S7.3.2(a) through (c), except that the words “Figure 27-1 or Figure ~~27-2~~ 27-1” are substituted for “Table 3” in paragraph S7.3.2(a)(3).
- (b) The maximum wattage at 12.8 V (design voltage): 65 watts on upper beam and 55 watts on lower beam.

S7.3.6 Type E headlighting system

- (a) A Type E headlighting system consists of two Type 2E1 headlamps and associated hardware, which are designed to conform to the requirements of paragraphs S7.3.2(a) through (c), except that the words “Figure 27-1 or Figure ~~27-2~~ 27-1” are substituted for “Table 3” in paragraph S7.3.2(a)(3).
- (b) The maximum wattage at 12.8 V (design voltage): 70 watts on upper beam and 60 watts on lower beam.

S7.3.7 Type F headlighting system. A Type F headlighting system consists of two Type UF and two Type LF headlamps and associated hardware, which are designed to conform to the following requirements:

- (26) (a) ~~Figures 11, 12, 13, and 14 as appropriate.~~
- (b) The photometric requirements of Figure 15-1 or Figure 15-2 of this TSD standard. A reaim tolerance of ± 0.25 degree is allowed for any test point on the Type LF lamp when tested alone, but is not allowed on the Type UF lamp when tested alone. For the

- test point 10U-90U, measurement shall be from the normally exposed surface of the lens face.
- (c) SAE Standard J1383 APR85 *Performance Requirements for Motor Vehicle Headlamps*, Sections 2.4, 2.5, 2.6, 4.1, 4.1.4, and 5.1.4.
- (d) When tested in accordance with section (c), the mounted assembly (either a Type UF or Type LF headlamp and its respective mounting ring, aiming ring, and aim adjustment mechanism) shall be designed to conform to the requirements of Figure 15-1 or Figure 15-2 for upper or lower beams, respectively, without reaim, when any conforming Type UF or LF headlamp is tested and replaced by another conforming headlamp of the same Type.
- (e) SAE J580 DEC86 *Sealed Beam Headlamp Assembly*, with the following exceptions:
- (1) Section 2.2 Mounting Ring shall read: “the adjustable ring upon which the sealed beam unit is mounted and which forces the sealed beam unit to seat against the aiming ring when assembled into a sealed beam assembly.”
 - (2) The definition “2.3 Aiming Ring” shall read: “The clamping ring that retains the sealed beam unit against the mounting ring, and that provides an interface between the unit’s aiming/seating pads and the headlamp aimer adapter (locating plate).”
 - (3) Section 4.1.1 Vibration Test does not apply.
 - (4) Sections 5.1.1.1 and 5.1.2.3 do not apply.
 - (5) Section 5.1.2.1 shall read: “When the headlamp assembly is tested in the laboratory, a minimum aiming adjustment of ± 2.5 degrees shall be provided in the horizontal plane and ± 4 degrees in the vertical plane.”
 - (6) Section 5.1.2.2 shall conclude: “* * * through an angle of ± 2.5 degrees and ± 4 degrees, respectively.”
 - (7) Section 5.1.6 is retitled: “Retaining Ring/Aiming Ring Tests”. The phrase “92x150 mm * * * 8.6 mm (0.340 in)” is added at the end of the table for flange thickness. The sentence beginning “The fastening means” is deleted.
- (27) (8) Figures 2, 3, and 4 do not apply, and the reference to them in section 4.5 is deleted, replaced by “Figure 16, Deflectometer, of Federal Motor Vehicle Safety Standard No. 108.”
- (f) A lens for a Type F headlamp incorporating an upper beam shall be labeled “UF”. A lens for a Type F headlamp incorporating a lower beam shall be labeled “LF”. The face of letters, numbers, or other symbols molded on the surface of the lens shall not be raised more than 0.5 mm (0.020 inch), and shall be placed no closer to the geometric center of the lens than 35 mm (1.375 inch). The marking shall be molded in the lens and shall be not less than 6.35 mm (0.25 inch) in size.

- (g) The maximum wattage at 12.8 volt (design voltage): 70 watts on the upper beam and 60 watts on the lower beam.
- (h) Type F headlamps may be mounted on common or parallel seating and aiming planes to permit simultaneous aiming of both headlamps, provided that when tested with any conforming Type UF and LF headlamps according to Section S10:
 - (1) The assembly (consisting of the Type UF and LF headlamps, mounting rings, the aiming/seating rings, and aim adjustment mechanism) shall be designed to conform to the test points of Figure 15-1 or Figure 15-2.
 - (2) There shall be no provision for adjustment between the common or parallel aiming and seating planes of the two lamps.
- (i) After a vibration test conducted in accordance with paragraph S8.8, the Type F system shall show no evidence of loose or broken parts, other than filaments, visible without magnification.

S7.3.8 Type G headlighting system. A Type G headlamp system consists of two Type 1G1 headlamps and two Type 2G1 headlamps, each of which is designed to conform to the following requirements:

- (26)
 - (a) ~~Figures 18 and 21.~~
 - (b) SAE Standard J1383 APR85 *Performance Requirements for Motor Vehicle Headlamps* (except paragraphs 1, 2.1.2, 2.8.2, 3, 4.1.1, 4.1.2, 4.1.3, 4.4, 4.6, 4.8 through 4.18, 5.1.1, 5.1.3, 5.1.5 through 5.1.16, 5.2.2, and 5.3.5 through 6.4). In paragraph 5.3.2, the words “and retaining rings” are omitted. In paragraph 4.5.2, the words “either Figure 28-1 or Figure 28-2” are substituted for “Table 3”.
 - (c) SAE Standard J580 DEC86 *Sealed Beam Headlamp Assembly*, with the following exceptions:
 - (1) Sections 2.2, 2.3, 4.1.1, 5.1.1.1, 5.1.2.3, 5.1.6, and 5.2.1.
- (28)
 - (2) Section 4.5 shall read: “Torque Deflection Test. The headlamp assembly to be tested shall be mounted in the designed vehicle position and set at nominal aim (0.0). A special adapter (Figure 22) for the deflectometer (Figure 16) shall be clamped onto the headlamp assembly. A torque of 2.25 N-m (20 inch-pounds) shall be applied to the headlamp assembly through the deflectometer, and a reading on the thumb wheel shall be taken. The torque shall be removed and a second reading on the thumb wheel shall be taken.”
 - (d) After a vibration test conducted in accordance with paragraph S8.8, there shall be no evidence of loose or broken parts, other than filaments, visible without magnification.
 - (e) The maximum wattage at 12.8 volts (design voltage) for the 1G1 and 2G1 upper beam is 55 watts and 43 watts respectively; for the 2G1 lower beam, 65 watts.
 - (f) A lens for a Type G headlamp incorporating only part of an upper beam shall be labeled 1G1. A lens for a Type G headlamp incorporating both part of an upper beam

and a lower beam shall be labeled 2G1. The face of letters, numbers, or other symbols molded on the surface of the lens shall not be raised more than 0.5 mm (0.020 inch), and shall be placed no closer to the geometric center of the lens than 35 mm (1.375 inch). The marking shall be molded in the lens and shall be not less than 6.35 mm (0.25 inch) in size.

S7.3.9 Type H headlighting system. A Type H headlamp system consists of two Type 2H1 headlamps and associated hardware, which are designed to conform to the following requirements:

- (a) Paragraphs S7.3.8 (a) through (d) except that in paragraph S7.3.8(b), the words “Figure 27-1 or Figure 27-2” are substituted for “Table 3”.
- (b) The maximum wattage at 12.8 volts (design voltage): 70 watts on the upper beam and 60 watts on the lower beam.
- (c) A lens for a Type H headlamp incorporating both an upper beam and a lower beam shall be labeled 2H1. The face of letters, numbers, or other symbols molded on the surface of the lens shall not be raised more than 0.5 mm (0.020 inch), and shall be placed no closer to the geometric center of the lens than 35 mm (1.375 inch). The marking shall be molded in the lens and shall be not less than 6.35 mm (0.25 inch) in size.

S7.4 Integral beam headlighting system

An integral beam headlighting system shall be designed to conform to the following requirements:

- (a) The system shall provide ~~in total not more than~~ two upper beams and two lower beams of the performance described in one of the following:
 - (1) In a four-headlamp system, each upper beam headlamp and each lower beam headlamp shall be designed to conform to the photometrics of one of the following:
 - (i) Figure 15-1 or Figure 15-2; or
 - (ii) Figure 15-1 or Figure 15-2, except that the upper beam test values at 2.5 D-V and 2.5D-12R and 12L shall apply to the lower beam headlamp and not to the upper beam headlamp, and the upper beam test point values at 1.5D-9R and 9L shall be 1000; or
 - (iii) Figure 28-1 or Figure 28-2.
 - (2) In a two-headlamp system, each headlamp shall be designed to conform to the photometrics of one of the following:
 - (i) Figure 17-1 or Figure 17-2; or
 - (ii) Figure 27-1 or Figure 27-2.

- (32) (3) In a system in which there is more than one beam contributor providing a lower beam, and/or more than one beam contributor providing an upper beam, each beam contributor in the system shall be designed to meet only the photometric performance requirements of Figure 15-1 or Figure 15-2 based upon the following mathematical expression: conforming test point value = 2 (Figure 15-1 or Figure 15-2 test point value)/total number of lower or upper beam contributors for the vehicle, as appropriate. The system shall be designed to use the Vehicle Headlamp Aiming Device (VHAD) as specified in paragraph S7.8.5.2.
- (b) The lower and upper beams shall be provided only as follows where each headlamp contains two light sources:
- (1) The lower beam shall be provided either by the most outboard light source (or the uppermost if arranged vertically) or by all light sources.
 - (2) The upper beam shall be provided either by the most inboard light source (or the lowermost if arranged vertically) or by all light sources.
- (c) The lower and upper beams shall be provided only as follows where each headlamp contains a single light source:
- (1) The lower beam shall be provided by the most outboard headlamps (or the uppermost if arranged vertically), and the lens of each such headlamp shall be permanently marked with the letter “L”.
 - (2) The upper beam shall be provided by the most inboard headlamps (or lowermost if arranged vertically), and the lens of each such headlamp shall be permanently marked with the letter “U”.
- (d) A headlamp or beam contributor designed to meet paragraphs (a)(1) or (a)(3) of this section and S7.8.5.1 may be mounted in an assembly to permit simultaneous aiming of the headlamps or beam contributors, provided that with any complying headlamp or beam contributor, the assembly complete with all lamps meets the appropriate photometric requirements when tested in accordance with S10.
- (e) Each integral beam headlamp system shall be designed to conform to the applicable photometric performance requirements in paragraph (a) of this section, when tested in accordance with Sections 4.1 and 4.1.4 of SAE Standard J1383 APR85 with any headlamps intended for use in such system. The term “aiming plane” means “aiming reference plane” or an appropriate vertical plane defined by the manufacturer as required in paragraph S7.8.1.
- (f) The system shall be aimable in accordance with the requirements of paragraph S7.8. A system that incorporates any headlamp or beam contributor that does not have a VHAD as an integral and indivisible part of the headlamp or beam contributor shall be designed so that the appropriate photometrics are met when any correctly aimed and photometrically conforming headlamp or beam contributor is removed from its mounting and aiming mechanism and when it is replaced without reaim by any conforming headlamp or beam contributor of the same type.

- (31) (g) A headlamp with a glass lens need not meet the abrasion resistance test (S8.2). A
{1} headlamp with a nonreplaceable glass lens need not meet the chemical resistance
test (S8.3). A headlamp with a glass lens and a non-plastic reflector need not meet the
internal heat test of paragraph S8.6.2. A headlamp of sealed design as verified in
paragraph S8.9 (Sealing) need not meet the corrosion (S8.4), dust (S8.5), or
humidity (S8.7) tests; however, the headlamp shall meet the requirements of
paragraphs 4.1, 4.1.2, 4.4 and 5.1.4 for corrosion and connector of SAE Standard J580
DEC86, *Sealed Beam Headlamp Assembly*. An integral beam headlamp may
incorporate light sources that are replaceable and are used for purposes other than
headlighting.
- (8) (h) When tested according to any of the procedures indicated in subparagraphs (1)
{1} through (7), each headlamp or beam contributor shall meet the appropriate
requirement:
- (1) After an abrasion test conducted in accordance with paragraph S8.2, the headlamp
or beam contributor shall meet the photometric requirements applicable to the
headlamp system under test.
 - (2) After the chemical resistance tests of paragraphs S8.3 and S8.10.1, the headlamp
or beam contributor shall have no surface deterioration, coating delamination,
fractures, deterioration of bonding or sealing materials, color bleeding or color
pickup visible without magnification, and the headlamp or beam contributor shall
meet the photometric requirements applicable to the headlamp system under test.
 - (3) After a corrosion test conducted in accordance with paragraph S8.4, there shall be
no evidence of external or internal corrosion or rust visible without magnification.
After a corrosion test conducted in accordance with paragraph S8.10.2, there shall
be no evidence of corrosion or rust visible without magnification on any part of
the headlamp reflector that receives light from a headlamp light source, on any
metal light or heat shield assembly, or on a metal reflector of any other lamp not
sealed from the headlamp reflector. Loss of adhesion of any applied coating shall
not occur more than 3.2 mm (0.125 inch) from any sharp edge on the inside or
outside. Corrosion may occur on terminals only if the current produced during the
test of paragraph S8.4(c) is not less than 9.7 amperes.
 - (4) After a dust test conducted in accordance with paragraph S8.5, the headlamp or
beam contributor shall meet the photometric requirements applicable to the
headlamp system under test.
 - (5) The headlamp or beam contributor shall first meet the requirements of
subparagraph (i) and then those of subparagraph (ii).
 - (i) After a temperature cycle test conducted in accordance with paragraph S8.6.1,
the headlamp or beam contributor shall show no evidence of delamination,
fractures, entry of moisture, deterioration of bonding material, color bleeding,
warpage, or deformation visible without magnification or lens warpage greater
than 3 mm (0.118 inch) when measured parallel to the optical axis at the point
of intersection of the axis of each light source with the exterior surface of the

lens, and it shall meet the photometric requirements applicable to the headlamp system under test.

- (ii) After an internal heat test conducted in accordance with paragraph S8.6.2, there shall be no lens warpage greater than 3 mm (0.118 inch) when measured parallel to the optical axis at the point of intersection of the axis of each light source with the exterior surface of the lens, and the headlamp or beam contributor ~~it~~ shall meet the photometric requirements applicable to the headlamp system under test.
- (6) After a humidity test conducted in accordance with paragraph S8.7, the inside of the headlamp or beam contributor shall show no evidence of delamination or moisture, fogging or condensation visible without magnification.
- (7) After a vibration test conducted in accordance with paragraph S8.8, there shall be no evidence of loose or broken parts, other than filaments, visible without magnification.
- (i) An integral beam headlamp may incorporate replaceable light sources that are used for purposes other than headlighting.

S7.5 Replaceable bulb headlamp system

Each replaceable bulb headlamp system shall be designed to conform to the following requirements:

- (a) The system shall provide only two lower beams and two upper beams and shall incorporate not more than two replaceable light sources in each headlamp.
- (b) The photometrics as specified in subparagraphs (c) through (e) of this paragraph (depicted in Figure 26), using any light source of the Type intended for use in such system.
- (c) The test requirements of sections 4.1 and 4.1.4 and the performance requirements of section 5.1.4 of SAE J1383 APR85, using the photometric requirements specified in subparagraphs (d) and (e) of this paragraph.
- (d) For a headlamp equipped with dual filament replaceable light sources, the following requirements apply:
 - (1) Headlamps designed to conform to the external aiming requirements of S7.8.5.1 shall have no mechanism that allows adjustment of an individual light source, or, if there are two light sources, independent adjustments of each reflector.
 - (2) The lower and upper beams of a headlamp system consisting of two lamps, each containing either one or two replaceable light sources, shall be provided as follows:
 - (i) The lower beam shall be provided in one of the following ways:

- (A) By the outboard light source (or upper one if arranged vertically), designed to conform to:
- (1) The lower beam requirements of Figure 27-1 or Figure 27-2, or Figure 17-1 or Figure 17-2, if the light sources in the headlamp system are any combination of dual filament replaceable light sources other than Type HB2; or
 - (2) The lower beam requirements of Figure 17-1 or Figure 17-2 if the light sources are Type HB2, or any combination of dual filament replaceable light sources that include Type HB2; or
- (B) By both light sources in the headlamp, designed to conform to the lower beam requirements specified above.
- (ii) The upper beam shall be provided in one of the following ways:
- (A) By the inboard light source (or the lower one if arranged vertically), designed to conform to:
- (1) The upper beam requirements of Figure 27-1 or Figure 27-2, or Figure 17-1 or Figure 17-2, if the light sources in the headlamp system are any combination of dual filament replaceable light sources other than that include Type HB2; or
 - (2) The upper beam requirements of Figure 17-1 or Figure 17-2 if the light sources are type HB2, or any combination of replaceable light sources that include Type HB2; or
- (B) By both light sources in the headlamp, designed to conform to the upper beam requirements specified above.
- (3) The lower and upper beams of a headlamp system consisting of four lamps, each containing a single replaceable light source, shall be provided as follows:
- (i) The lower beam shall be provided by the outboard lamp (or the upper one if arranged vertically), designed to conform to:
- (A) The lower beam requirements of Figure 27-1 or Figure 27-2, or Figure 15-1 or Figure 15-2, if the light sources in the headlamp system are any combination of dual filament light sources other than Type HB2; or
 - (B) The lower beam requirements of Figure 15-1 or Figure 15-2 if the light sources are Type HB2, or dual filament light sources other than Type HB1 and HB5. The lens of each such headlamp shall be marked with the letter "L".
- (ii) The upper beam shall be provided by the inboard lamp (or the lower one if arranged vertically), designed to conform to:

- (A) The upper beam requirements of Figure 27-1 or Figure 27-2, or Figure 15-1 or Figure 15-2, if the light sources in the headlamp system are any combination of dual filament light sources other than Type HB2; or
 - (B) The upper beam requirements of Figure 15-1 or Figure 15-2 if the light sources are Type HB2, or dual filament light sources other than Type HB1 and Type HB5. The lens of each such headlamp shall be marked with the letter "U".
- (e) The following requirements apply to a headlamp system equipped with any combination of replaceable light sources, except those specified in paragraph (d) of this section:
- (1) Headlamps designed to conform to the external aim requirements of S7.8.5.1 shall have no mechanism that allows adjustment of an individual light source, or, if there are two replaceable light sources, independent adjustment of each reflector.
 - (2) The lower and upper beams of a headlamp system consisting of two lamps, each containing a combination of two replaceable light sources (other than those combinations specified in subparagraph (d) of this paragraph), shall be provided only as follows:
 - (i) The lower beam shall be provided in one of the following ways:
 - (A) By the outboard light source (or the uppermost one if arranged vertically), designed to conform to the lower beam requirements of Figure 17-1 or Figure 17-2; or
 - (B) By both light sources, designed to conform to the lower beam requirements of Figure 17-1 or Figure 17-2.
 - (ii) The upper beam shall be provided in one of the following ways:
 - (A) By the inboard light source (or the lower one if arranged vertically), designed to conform to the upper beam requirements of Figure 17-1 or Figure 17-2; or
 - (B) By both light sources, designed to conform to the upper beam requirements of Figure 17-1 or Figure 17-2.
 - (3) The lower and upper beams of a headlamp system consisting of four lamps, using any combination of replaceable light sources except those specified in subparagraph (d) of this paragraph, each lamp containing only a single replaceable light source, shall be provided only as follows:
 - (i) The lower beam shall be produced by the outboard lamp (or the upper one if arranged vertically), designed to conform to the lower beam requirements of Figure 15-1 or Figure 15-2. The lens of each headlamp shall be permanently marked with the letter "L".

- (ii) The upper beam shall be produced by the inboard lamp (or the lower one if arranged vertically), designed to conform to the upper beam requirements of Figure 15-1 or Figure 15-2. The lens of each headlamp shall be permanently marked with the letter "U".

(f) [CONTENT DELETED]

- (33) (g) The lens of each replaceable bulb headlamp shall bear permanent marking in front of each replaceable light source with which it is equipped ~~that stating~~ the HB Type, if the light source is designed to conform to subparagraphs (a) through (e) of paragraph S7.7, or bearing the bulb marking/designation specified or provided in accordance with subsection 108(5) of the MVSR, provided in compliance with Section VIII of appendix A of Part 564, if the light source is designed to conform to subparagraph (g) of paragraph S7.7. No marking need be provided if the only replaceable light source in the headlamp is Type HB1.
- (h) The system shall be aimable in accordance with paragraph S7.8.
- (i) Each headlamp shall meet the requirements of paragraphs S7.4 (g) and (h), except that the sentence in paragraph (g) to verify sealing according to section S8.9 (Sealing) does not apply.
- (j) A replaceable bulb headlighting system may incorporate replaceable light sources that are used for purposes other than headlighting.

S7.6 Combination headlighting system

A combination headlighting system shall be comprised of either two headlamps designed to conform to the requirements of S7.6.2 or any combination of four headlamps designed to conform to the requirements of S7.3.7, S7.4, or S7.5 of this TSD standard.

S7.6.1 A combination headlighting system shall provide ~~in total not more than~~ two upper beams and two lower beams. When installed on a motor vehicle, the headlamps (or parts thereof) that provide the lower beam shall be of the same type and provide a symmetrical effective projected luminous lens area when illuminated.

S7.6.2 In a combination headlighting system consisting of two headlamps, each headlamp shall be designed to conform to Figure 17-1 or Figure 17-2 and shall be a combination of two different headlamps chosen from the following types: a Type F headlamp, an integral beam headlamp, and a replaceable bulb headlamp.

S7.6.2.1 That part of the headlamp which contains an integral beam headlamp, or beam contributors used in place of a single headlamp, shall be designed to conform to the requirements of S7.4(c) through (h) of this TSD standard.

S7.6.2.2 That part of the headlamp which contains a replaceable bulb headlamp shall be designed to conform to the requirements of S7.5 of this TSD standard.

S7.6.3 In a combination headlighting system consisting of four headlamps, each headlamp shall be designed to conform to Figure 15-1 or Figure 15-2, or if it is an integral beam

headlamp in which there is more than one beam contributor, it shall be designed to conform to Figure 15-1 or Figure 15-2 in the manner required by S7.4(a)(3) of this TSD standard.

S7.7 Replaceable light sources

Each replaceable light source shall be designed to conform to the dimensions and electrical specifications specified or provided in accordance with subsection 108(5) of the MVSR ~~furnished with respect to it pursuant to part 564 of this chapter~~, and shall conform to the following requirements:

- (a) If other than an HB Type, the light source shall be marked with the bulb marking designation specified or provided in accordance with subsection 108(5) of the MVSR ~~specified for it in compliance with Appendix A or Appendix B of part 564 of this chapter~~. The base of each HB Type shall be marked with its HB Type designation. Each replaceable light source shall also be marked with the symbol DOT and with a name or trademark in accordance with paragraph S7.2.
- {1} (b) The measurement of maximum power and luminous flux that is specified or provided in accordance with subsection 108(5) of the MVSR ~~submitted in compliance with Appendix A or Appendix B of part 564 of this chapter~~ shall be made in accordance with this paragraph. The filament or discharge arc shall be seasoned before measurement of either. Measurement shall be made with the direct current test voltage regulated within one quarter of one percent. The test voltage shall be 12.8 V. The measurement of luminous flux shall be in accordance with the Illuminating Engineering Society of North America, LM-45, *IES Approved Method for Electrical and Photometric Measurements of General Service Incandescent Filament Lamps* (April 1980); shall be made with the black cap installed on Type HB1, Type HB2, Type HB4, and Type HB5, and on any other replaceable light source so designed; and shall be made with the electrical conductor and light source base shrouded with an opaque white cover, except for the portion normally located within the interior of the lamp housing. The measurement of luminous flux for the Types HB3 and HB4 shall be made with the base covered with a white cover as shown in the drawings for Types HB3 and HB4 specified or provided in accordance with subsection 108(5) of the MVSR ~~filed in Docket No. NHTSA 98-3397~~. (The white cover is used to eliminate the likelihood of incorrect lumen measurement that will occur should the reflectance of the light source base and electrical connector be low).
- {1} (c) The capsule, lead wires and/or terminals, and seal on each Type HB1, Type HB3, Type HB4, and Type HB5 light source, and on any other replaceable light source which uses a seal, shall be installed in a pressure chamber as shown in Figure 25 so as to provide an airtight seal. The diameter of the aperture in Figure 25 on a replaceable light source (other than an HB Type) shall be that dimension specified or provided for such light source in accordance with subsection 108(5) of the MVSR ~~furnished for such light source in compliance with Appendix A or Appendix B of part 564 of this chapter~~. An airtight seal exists when no air bubbles appear on the low pressure (connector) side after the light source has been immersed in water for one minute while inserted in a cylindrical aperture specified for the light source, and subjected to an air pressure of 70 kPa (10 P.S.I.G.) on the glass capsule side.

- (d) The measurement of maximum power and luminous flux that is specified or provided in accordance with subsection 108(5) of the MVSR submitted in compliance with section VII of Appendix A of part 564 of this chapter, or section IV of Appendix B of part 564 of this chapter, shall be made with the direct current test voltage regulated within one quarter of one percent. The test voltage shall be 12.8 v. The measurement of luminous flux shall be in accordance with the Illuminating Engineering Society of North America, LM-45; *IES Approved Method for Electrical and Photometric Measurements of General Service Incandescent Filament Lamps* (April 1980). The filament of a replaceable light source shall be seasoned before such measurement. The white covers are used to eliminate the likelihood of incorrect lumens measurement that will occur should the reflectance of the light source base and electrical connector be low.
- (1) For a light source with a resistive element type filament, seasoning of the light source shall be made in accordance with section 2.9 of SAE Standard J1383 APR85, *Performance Requirements for Motor Vehicle Headlamps*. The measurement of luminous flux shall be made with the black cap installed on Type HB1, Type HB2, Type HB4, and Type HB5 light sources, and on any other replaceable light source so designed, and shall be made with the electrical conductor and light source base shrouded with an opaque white colored cover, except for the portion normally located within the interior of the lamp housing. The measurement of luminous flux for Type HB3 and Type HB4 shall be made with the base covered with the white cover shown in the drawings for Types HB3 and HB4 specified or provided in accordance with subsection 108(5) of the MVSR filed in Docket No. NHTSA 98-3397.
 - (2) For a light source using excited gas mixtures as a filament or discharge arc, seasoning of the light source system, including any ballast required for its operation, shall be made in accordance with section 4.0 of SAE Recommended Practice J2009 FEB93, *Discharge Forward Lighting Systems*. With the test voltage applied to the ballast input terminals, the measurement of luminous flux shall be made with the black cap installed, if so designed, and shall be made with the electrical conductor and light source base shrouded with an opaque white colored cover, except for the portion normally located within the interior of the lamp housing.
- (e) If a ballast is required for operation, each ballast shall bear the following permanent markings:
- (1) Name or logo of ballast manufacturer;
 - (2) Ballast part number or unique identification;
 - (3) Part number or other unique identification of the light source for which the ballast is designed;
 - (4) Rated laboratory life of the light source/ballast combination, if the information for the light source has been specified or provided in accordance with subsection 108(5) of the MVSR filed in Appendix B of part 564 of this chapter;

- (5) A warning that ballast output voltage presents the potential for severe electrical shock that could lead to permanent injury or death;
- (6) Ballast output power in watts and output voltage in rms volts AC or DC; and
- (7) The symbol "DOT".
- (f) For light sources that use excited gas mixtures as a filament or discharge arc, the "rated laboratory life" shall be determined in accordance with sections 4.3 and 4.9 of SAE Recommended Practice J2009 FEB93, *Forward Discharge Lighting Systems*.
- {1} (g) After the force deflection test conducted in accordance with S9, the permanent deflection of the glass envelope shall not exceed 0.13 mm in the direction of the applied force.

S7.8 Aimability performance requirements

S7.8.1

- (a) Each headlamp or beam contributor that is not visually/optically aimable in accordance with S7.8.5.3 of this ~~TSD standard~~ shall be equipped with fiducial marks, aiming pads, or similar references of sufficient detail and accuracy for determination of an appropriate vertical vehicle plane to be used with the photometric procedures of SAE J1383 APR85 for correct alignment with the photometer axis when being tested for photometric compliance, and to serve as for the aiming reference when the headlamp or beam contributor is installed on a motor vehicle. The fiducial marks, aiming pads, or similar references are protrusions, bubble vials, holes, indentations, ridges, scribed lines, or other readily identifiable marks established and described by the vehicle or headlamp manufacturer.
 - (b) Each motor vehicle manufactured on and after September 1, 1998, shall be equipped with headlamps or beam contributors which have a mark or markings that are visible from the front of the headlamp or beam contributor when installed on the vehicle to identify the optical axis of the headlamp or beam contributor to assure proper horizontal and vertical alignment of the aiming screen or optical aiming equipment. The manufacturer is free to choose the design of the mark or markings. The mark or markings may be on the interior or exterior of the lens or indicated by a mark or central structure on the interior or exterior of the headlamp.
 - (c) Each headlamp that is visually/optically aimable in accordance with S7.8.5.3 of this ~~TSD standard~~ shall be marked in accordance with S7.8.5.3(f).
- (12) **S7.8.2** Except as provided in this paragraph, each headlamp shall be installed on a motor
(29) vehicle with a mounting and aiming mechanism that allows aim inspection and adjustment of
(40) both vertical and horizontal aim, and is accessible for those purposes without removal of any
{1} vehicle parts, except for protective covers removable without the use of tools.

(12) **S7.8.2.1**(40)
{1}

- (a) When installed on the vehicle, adjustment of one aim axis through its full on-vehicle range shall not cause the aim of the other axis to deviate more than ± 0.76 degree.
- (b) If the performance specified in paragraph (a) of this section is not achievable, the requirements of S7.8.5.2(b)(3) apply, except that if the aiming mechanism is not a VHAD, ~~the requirements specific to VHADs are not applicable, and~~ the instruction shall be specific to the aiming mechanism installed.
- (c) A visually/optically aimable headlamp that has a lower beam shall not have a horizontal adjustment mechanism unless such mechanism meets the requirements of paragraph S7.8.5.2 of this TSD standard.

(12) **S7.8.2.2** If the headlamp is aimed by moving the reflector relative to the lens and headlamp housing, or vice versa, it shall:(40)
{1}

- (a) Allow movement of the headlamp system, when tested in the laboratory, to be not less than the full range of pitch on the vehicle on which the headlamp system is installed and for the horizontal aim range limits of S7.8.4,
- (b) Conform with the photometrics applicable to it with the lens at any position relative to the reflector within the range limits as specified in S7.8.2.2(a),
- (c) Be exempted from the aim range limits for testing in a laboratory in S7.8.3, and
- (d) Be exempted from S7.8.4 if it is visually/optically aimable and has fixed horizontal aim.

S7.8.2.3 [CONTENT DELETED]

(12) **S7.8.3** When a headlamp system is tested in a laboratory, the range of its vertical aim shall
(40) not be less than ± 4 degrees from the nominal correct aim position for the intended vehicle
{1} application. When installed on a motor vehicle, the range of vertical aim shall be not less than the full range of pitch of the vehicle on which the headlamp system is installed. The installed range of static pitch angle shall as a minimum be determined from unloaded vehicle ~~mass weight~~ to gross vehicle weight rating, and incorporate pitch angle effects from maximum trailer or trunk loadings, the full range of tire intermix sizes and suspensions recommended and/or installed by the vehicle manufacturer, and the anticipated effects of variable passenger loading. The vertical aim adjustment mechanism shall be continuously adjustable over the full range.

(12) **S7.8.4** When a headlamp system is tested in a laboratory, the range of its horizontal aim
(40) shall be not less than ± 2.5 degrees from the nominal correct aim position for the intended
{1} vehicle application.

S7.8.5 When activated in a steady-burning state, headlamps shall not have any styling ornament or other feature, such as a translucent cover or grill, in front of the lens. Headlamp wipers may be used in front of the lens provided that the headlamp system is designed to conform with all applicable photometric requirements with the wiper stopped in any position in front of the lens. When a headlamp system is installed on a motor vehicle, it shall be

aimable with at least one of the following: an externally applied aiming device, as specified in S7.8.5.1; an on-vehicle headlamp aiming device installed by the vehicle or lamp manufacturer, as specified in S7.8.5.2; or by visual/optical means, as specified in S7.8.5.3.

S7.8.5.1 External aiming. Each headlamp system that is capable of being mechanically aimed by externally applied headlamp aiming devices shall be mechanically aimable using the equipment specified in SAE Standard J602 OCT80, *Headlamp Aiming Device for Mechanically Aimable Sealed Beam Headlamp Units* without the removal of any ornamental trim rings, covers, wipers, or other vehicle parts.

- (41) (a) The aim of the headlamps in each headlamp system, other than a headlamp system designed to conform to section S7.3, that is designed to use such external aiming devices, shall not deviate more than 0.30 degree when a downward torque of 2.25 N-m (20 ~~inch-pounds~~ ~~pound-inch~~) is removed from the headlamp in its design operating position. The downward force used to create the torque shall be applied parallel to the aiming reference plane, through the aiming pads, and displaced forward using a lever arm such that the force is applied on an axis that is perpendicular to the aiming reference plane and originates at the center of the aiming pad pattern (see Figures 4-1 and 4-3). For headlamps using the aiming pad locations of Group I, the distance between the point of application of force and the aiming reference plane shall be not less than 168.3 mm (6.625 inches) plus the distance from the aiming reference plane to the secondary plane, if used [see section S7.8.5.1(d)(1)]. For headlamps using the aiming pad locations of Group II, the distance between the point of application of force and the aiming reference plane shall be not less than 167.9 mm (6.609 inches) plus the distance from the aiming reference plane to the secondary plane, if used. For headlamps using the nonadjustable Headlamp Aiming Device Locating Plates for the 146 mm diameter, the 176 mm diameter, and the 92 x 150 mm sealed beam units, the distance between the point of application of force and the aiming plane shall, respectively, be not less than 177.4 mm (6.984 inches), 176.2 mm (6.937 inches), and 193.7 mm (7.625 inches). Each headlamp system that is designed to conform to paragraph S7.5 and that is designed to use such external aiming devices, ~~and which is manufactured on or after September 1, 1990~~, shall comply with this paragraph.
- (b) When a headlamp is installed on a motor vehicle, its aim in any direction shall not change by more than 0.30 degree, nor shall the lamp recede more than 2.5 mm (0.1 inch) after being subjected to an inward force of 222 Newtons (50 pounds) applied evenly to the lens parallel to the mechanical axis.
- (12) (c) Each headlamp system mounting and aiming mechanism shall be subjected to a salt
(40) spray (fog) test in accordance with ASTM B117-73, *Method of Salt Spray (Fog)*
{1} *Testing*, for a period of 50 hours, consisting of two successive 25-hour periods of 24 hours exposure followed by 1 hour of drying. At the end of 50 hours, the headlamp system shall be capable of meeting any of the applicable requirements of paragraph S7.8.
- (d) Each headlamp system which is designed to use the Headlamp Aiming Device Locating Plates with adjustable legs for the 100 x 165 mm unit and the 142 x 200 mm

unit, and which has adjustable length legs, shall meet the requirements of subparagraphs (1) and (2) below.

- (1) The lens shall have three aiming pads which meet the requirements of Figure 4, Dimensional Specifications for Location of Aiming Pads on Replaceable Bulb Headlamp Units. The aiming pads need not be centered at the geometric center of the lens or on the optical axis. Except as provided in subparagraph (2), a whole number which represents the distance in multiples of 2.54 mm (tenths of an inch) [i.e. 7.62 mm (0.3 inch) = 3] from the aiming reference plane to the respective aiming pads that are not in contact with that plane shall be inscribed adjacent to each respective aiming pad on the lens. The height of these numbers shall be not less than 4 mm (0.157 inch). If there is interference between the plane and the area of the lens between the aiming pads, the whole number represents the distance to a secondary plane. The secondary plane shall be located parallel to the aiming reference plane and as close to the lens as possible without causing interference.
 - (2) If the most forward aiming pad is the lower inboard aiming pad, then the dimensions may be placed anywhere on the lens. The dimension for the outboard aiming pad (Dimension F in Figure 4-4) shall be followed by the letter “H” and the dimension for the center aiming pad shall be followed by the letter “V”. The dimensions shall be expressed in multiples of 2.54 mm (tenths of an inch).
 - (e) Each headlamp may be designed to use the nonadjustable Headlamp Aiming Device Locating Plate for the 100 x 165 mm unit, the 142 x 200 mm unit, the 146 mm diameter unit, or the 178 mm diameter unit of SAE J602, or the 92 x 150 mm Type F unit, and incorporate lens mounted aiming pads as specified for those units in Figures 10, 13, 5, or 7, respectively, in SAE J1383 APR85 or Figure 11 of this TSD standard for the Type F unit. If so designed, no additional lens marking is necessary to designate the type of plate or dimensions.
- (32) **S7.8.5.2 On-vehicle aiming.** Each headlamp system that is capable of being aimed by equipment installed on the vehicle shall include a Vehicle Headlamp Aiming Device (VHAD) that conforms to the following requirements:
- (a) *Aim.* The VHAD shall provide for headlamp aim inspection and adjustment in both the vertical and horizontal axes.
 - (1) *Vertical aim.* The VHAD shall include the necessary references and scales relative to the horizontal plane to assure correct vertical aim for photometry and aiming purposes. An off-vehicle measurement of the angle of the plane of the ground is permitted. In addition, an equal number of graduations from the “0” position representing angular changes in the axis in the upward and downward directions shall be provided.
 - (i) Each graduation shall represent a change in the vertical position of the mechanical axis not larger than 0.19 degree [25 mm at 7.62 m (1 inch at 25 ft.)] to provide for variations in aim at least 1.2 degrees above and below the horizontal and to have an accuracy relative to the zero mark of less than 0.1 degree.

- (ii) The VHAD shall be marked to indicate headlamp aim movement in the upward and downward directions.
 - (iii) Each graduation shall indicate a linear movement of the scale indicator of not less than 1.27 mm (0.05 inch) if a direct reading analog indicator is used. If a remote reading indicator is provided, it shall represent the actual aim movement in a clear, understandable format.
 - (iv) The vertical indicator shall perform through a minimum range of ± 1.2 degrees.
 - (v) Means shall be provided in the VHAD for compensating for deviations in floor slope less than 1.2 degrees from the horizontal that would affect the correct positioning of the headlamp for vertical aim.
 - (vi) The graduations shall be legible under an illumination level not greater than 325 lux (30 foot-candles), measured at the top of the graduation by an observer having 20/20 vision (Snellen), and shall permit aim adjustment to within 0.19 degree [25 mm at 7.62 m (1 inch at 25 ft.)].
- (2) *Horizontal aim.* The VHAD shall include references and scales relative to the longitudinal axis of the vehicle necessary to assure correct horizontal aim for photometry and aiming purposes. A “0” mark shall be used to indicate alignment of the headlamps relative to the longitudinal axis of the vehicle. In addition, an equal number of graduations from the “0” position representing equal angular changes in the axis relative to the vehicle axis shall be provided.
- (i) Each graduation shall represent a change in the horizontal position of the mechanical axis not greater than 0.38 degree [50 mm at 7.62 m (2 inches at 25 ft.)] to provide for variations in aim at least 0.76 degree [100 mm at 7.62 m (4 inches at 25 ft.)] to the left and right of the longitudinal axis of the vehicle, and shall have an accuracy relative to the zero mark of less than 0.1 degree.
 - (ii) The VHAD shall be marked to indicate headlamp aim movement in the left and right directions.
 - (iii) The graduations shall be legible under an illumination level not greater than 325 lux (30 foot-candles), measured at the top of the graduation by an observer having 20/20 vision (Snellen), and shall permit aim adjustment to within 0.38 degree [50 mm at 7.62 m (2 inches at 25 ft.)].
 - (iv) The horizontal indicator shall perform through a minimum range of ± 0.76 degree [100 mm at 7.62 m (4 inches at 25 ft.)]; however, the indicator itself shall be capable of recalibration over a movement of ± 2.5 degrees relative to the longitudinal axis of the vehicle to accommodate any adjustment necessary for recalibrating the indicator after vehicle repair from accident damage.
- (42) (b) Aiming instructions
- (43)

- (1) The instructions for properly aiming the headlighting system using the VHAD shall be provided on a label permanently affixed to the vehicle adjacent to the VHAD or in the vehicle operator's manual. The instructions shall advise that the headlighting system is properly aimed if the appropriate vertical plane (as defined by the vehicle manufacturer) is perpendicular to both the longitudinal axis of the vehicle and a horizontal plane when the vehicle is on a horizontal surface and when the VHAD is set at "0" vertical and "0" horizontal.
 - (2) Should a remote indicator or a remote indicator and adjuster be provided, the instructions shall be placed in the operator's manual, and may also be placed on a label adjacent to the VHAD.
 - (3) Should the mechanism not meet the requirements of S7.8.2.1, ~~on each motor vehicle manufactured on or after September 1, 1990~~, a cautionary label shall be placed adjacent to the mechanism stating the caution and including either the reason for the caution or the corrective action necessary. Each such label shall also refer the reader to the vehicle operator's manual for complete instructions. Each such vehicle shall be equipped with an operator's manual containing the complete instructions appropriate for the mechanism installed.
- (c) Each headlamp equipped with a VHAD that is manufactured for use on motor vehicles manufactured on or after September 1, 1998, shall be manufactured with its calibration permanently fixed by its manufacturer. Calibration in this case means the process of accurately aligning the geometry of the VHAD devices with the beam pattern for the purposes of compliance with the TSD standard.
- (d) Testing the VHAD
- (1) The headlamp assembly [the headlamp(s) and the VHAD(s)] shall be mounted on a level goniometer aligned to a photometer located not less than 18.3 m (60 ft.) from the VHAD assembly. The assembly shall be mechanically aimed using the VHAD, in accordance with the manufacturer's instructions as provided with the vehicle on which the VHAD is intended to be used. A 0.25-degree reaim is permitted in any direction at any test point to allow for variations in readings between laboratories. The test shall be conducted in accordance with the procedures of paragraphs 4.1 and 4.1.4 of SAE J1383 APR85. Under these conditions, the mounted headlamp assembly shall be designed to conform to the photometric requirements appropriate for the headlamp system under test.
 - (2) When tested in accordance with subsection (1) of this section with any replacement headlamp unit(s) or light sources intended for use in the system under test, the VHAD and headlamp system shall be designed to conform to the photometric performance requirements appropriate for the system under test.
 - (3) The same VHAD and associated headlamp(s) (or headlamp assembly) shall be rigidly mounted in a headlamp test fixture and comply with the following laboratory test procedures:

- (i) Each graduation on the horizontal and vertical aim scales shall be checked and any variation from the correct aim shall not exceed ± 0.2 degree and ± 0.1 degree, respectively.
- (ii) With the aiming plane horizontal and vertical and with the scale on the device set at 0, the aimer shall be adjusted before each of the following tests to assure that the indicators are centered at 0.
 - (A) The VHAD and an unlighted headlamp assembly shall be stabilized at -7 ± 3 degrees C (20 ± 5 degrees F) in a circulating air environmental test chamber. After a period of 30 minutes, when measured at that soak temperature, the variation from correct horizontal ~~and~~ of vertical aim shall not exceed ± 0.2 degree and ± 0.1 degree, respectively.
 - (B) The VHAD and the headlamp assembly, with its highest wattage filament (or combination of filaments intended to be used simultaneously) energized at its design voltage, shall then be stabilized at 38 ± 3 degrees C (100 ± 5 degrees F) in a circulating air environmental test chamber. After a period of 30 minutes, when measured at that soak temperature, the variation from correct horizontal and vertical aim shall not exceed ± 0.2 degree and ± 0.1 degree, respectively.
 - (C) The VHAD and an unlighted headlamp assembly shall then be placed in a circulating air environmental test chamber and exposed to a temperature of 60 ± 3 degrees C (140 ± 5 degrees F) for 24 hours, followed by a temperature of -40 ± 3 degrees C (-40 ± 5 degrees F) for 24 hours and then permitted to return to room temperature, after which the VHAD and headlamp assembly shall show no damage which would impair its ability to perform as specified herein. The variation from correct horizontal or vertical aim shall not exceed ± 0.2 degree and ± 0.1 degree, respectively.
 - (D) The VHAD and headlamp assembly shall then be tested according to the corrosion test procedure of paragraph S7.8.5.1(c).
 - (E) The VHAD and headlamp assembly shall then be tested for photometric compliance as specified in paragraphs S7.8.5.2(c)(1) and (2).

S7.8.5.3 Visual/optical aiming. Each visually/optically aimable headlamp shall be designed to conform to the following requirements:

- (a) *Vertical aim, lower beam.* Each lower beam headlamp shall have a cutoff in the beam pattern. It may be either on the left side or the right side of the optical axis, ~~but once chosen for a particular headlamp system's design, the side chosen for the cutoff shall not be changed for any headlamps intended to be used as replacements for those system's headlamps.~~
- (1) *Vertical position of cutoff.* The headlamp shall be aimed vertically so that the cutoff is on the left side, at 0.4 degree down from the H-H line, or on the right side, at the H-H line.

- (2) *Vertical gradient.* The gradient of the cutoff measured at either 2.5 degrees L or 2.0 degrees R shall be not less than 0.13 based on the procedure of paragraph S7.8.5.3(a)(5).
- (3) *Horizontal position of the cutoff.* The width shall be not less than 2.0 (two) degrees, with not less than 2.0 (two) degrees of its actual width centered at either 2.5 degrees L, or 2.0 degrees R.
- (4) *Maximum inclination of cutoff.* The vertical location of the highest gradient at the ends of the minimum width shall be within ± 0.2 degree of the vertical location of the maximum gradient measured at the appropriate vertical line (at either 2.5 degrees L for a left-side cutoff, or 2.0 degrees R for a right-side cutoff).
- (5) *Measuring the cutoff parameter*
- (i) The headlamp shall be mounted on a fixture which simulates its actual design location on any vehicle for which the headlamp is intended. The fixture, with the headlamp installed, shall be attached to the goniometer table in such a way that the fixture alignment axes are coincident with the goniometer axes. The headlamp shall be energized at the specified test voltage.
- (ii) The headlamp beam pattern shall be aimed with the cutoff at the H-H axis. There shall be no adjustment, shimming, or modification of the horizontal axis of the headlamp or test fixture, unless the headlamp is equipped with a VHAD. In this case, the VHAD shall be adjusted to zero.
- (iii) A vertical scan of the beam pattern shall be conducted for a headlamp with a left-side gradient by aligning the goniometer on a vertical line at 2.5 degrees L and scanning from 1.5 degrees U to 1.5 degrees D. For a headlamp with a right-side gradient, a vertical scan of the beam pattern shall be conducted by aligning the goniometer on a vertical line at 2.0 degrees R and scanning from 1.5 degrees U to 1.5 degrees D.
- (iv) Determine the maximum gradient within the range of the scan by using the formula: $G = \log E(a) - \log E(a + 0.1)$, where “G” is the gradient, “E” is illuminance illumination, and “a” is vertical angular position. The maximum value of the gradient “G” determines the vertical angular location of the cutoff. Perform vertical scans at 1.0 degree L and R of the measurement point of the maximum gradient to determine the inclination.
- (b) *Horizontal aim, lower beam.* There shall be no adjustment of horizontal aim unless the headlamp is equipped with a horizontal VHAD. If the headlamp has a VHAD, it shall be set to zero.
- (c) *Vertical aim, upper beam.*
- (1) If the upper beam is combined in a headlamp with a lower beam, the vertical aim of the upper beam shall not be changed from the aim set using the procedures of paragraphs S7.8.5.3(a) and (b) used for the lower beam.

- (2) If the upper beam is not combined in a headlamp with a lower beam, the vertical aim of the upper beam shall be adjusted so that the maximum beam intensity is located on the H-H axis.
- (d) Horizontal aim, upper beam
- (1) If the upper beam is combined in a headlamp with a lower beam, the horizontal aim of the upper beam shall not be changed from the aim set using the procedures of paragraphs S7.8.5.3(a) and (b) used for the lower beam.
- (2) If the upper beam is not combined in a headlamp with the lower beam and has fixed horizontal aim or has a horizontal VHAD, then the headlamp shall be mounted on a fixture which simulates its actual design location on any vehicle for which the headlamp is intended. The fixture, with the headlamp installed, shall be attached to the goniometer table in such a way that the fixture alignment axes are coincident with the goniometer axes. The headlamp shall be energized at $12.8 \text{ V} \pm 0.20 \text{ mV}$. There shall be no adjustment, shimming, or modification of the horizontal axis of the headlamp or test fixture, unless the headlamp is equipped with a VHAD. In this case, the VHAD shall be adjusted to zero.
- (3) If the upper beam is not combined in a headlamp with a lower beam, and it does not have a VHAD, the horizontal aim of the upper beam shall be adjusted so that the maximum beam intensity is located on the V-V axis.
- (e) *Photometric requirements and measurement*
- (1) Instead of being designed to conform to the photometric requirements of Figures 15-1, 17-1, 27-1, or 28-1, a visually/optically aimable headlamp shall be designed to conform to the requirements of Figures 15-2, 17-2, 27-2, or 28-2 when tested in accordance with paragraph (2) and SAE J575 DEC88, with the distance from the photometer to the headlamp no less than 18.3 m.
- (2) If the lower beam has a left-side cutoff, reaim the headlamp vertically to place the maximum gradient found in paragraph S7.8.5.3 at 0.4 degree below the H-H line. For a headlamp with a lower beam right-side cutoff, place the maximum gradient found in paragraph S7.8.5.3 at the H-H line. For an upper beam, the headlamp would already be aimed at the end of the procedure found in paragraph S7.8.5.3. A 0.25 degree reaim is permitted in any direction at any test point.
- (f) Marking
- (1) *Headlamp optical axis mark.* There shall be a mark or markings identifying the optical axis of the headlamp visible from the front of the headlamp when installed on the vehicle, to assure proper horizontal and vertical alignment of the aiming screen or optical aiming equipment with the headlamp being aimed. The manufacturer is free to choose the design of the mark or markings. The mark or markings may be on the interior or exterior of the lens or indicated by a mark or central structure on the interior or exterior of the headlamp.
- (2) *Visual/optical aimability identification marks*

- (i) The lens of a lower beam headlamp shall be marked “VOL” if the headlamp is intended to be visually/optically aimed using the left side of the lower beam pattern.
- (ii) The lens of a lower beam headlamp shall be marked “VOR” if the headlamp is intended to be visually/optically aimed using the right side of the lower beam pattern.
- (iii) The lens of each sealed beam or integral beam headlamp shall be marked “VOR” if the headlamp is of a type that was manufactured before May 1, 1997, and if such headlamp type has been redesigned since then to be visually/optically aimable.
- (iv) The lens of a headlamp that is solely an upper beam headlamp and intended to be visually/optically aimed using the upper beam shall be marked “VO”.
- (v) Each letter used in marking according to this paragraph shall be not less than 3 mm high.

(12) **S7.9 Motorcycles**

Each motorcycle shall be equipped with a headlighting system designed to conform to the following requirements.

S7.9.1 A motorcycle manufactured before November 19, 2001, the Mandatory Compliance Date of Revision 3 of this TSD ~~September 1, 2000~~, may be equipped with:

- (a) A headlighting system designed to conform to SAE Standard J584, *Motorcycle and Motor Driven Cycle Headlamps*, April 1964, or to SAE Standard J584, April 1964, with the photometric specifications of Figure 32 and the upper beam aimability specifications of paragraph S7.9.3; or
- (b) One half of any headlighting system specified in S7.1 through S7.6 which provides both a full upper beam and full lower beam. Where more than one lamp must be used, the lamps shall be mounted vertically, with the lower beam as high as practicable.

S7.9.2 A motorcycle manufactured on or after November 19, 2001, the Mandatory Compliance Date of Revision 3 of this TSD ~~September 1, 2000~~, shall be equipped with:

- (a) A headlighting system designed to conform to SAE Standard J584, *Motorcycle and Motor Driven Cycle Headlamps*, April 1964, with the photometric specifications of Figure 32 and the upper beam aimability specifications of paragraph S7.9.3; or
- (b) A headlighting system that conforms to S7.9.1(b).

S7.9.3 The upper beam of a multiple beam headlamp designed to conform to the photometric requirements of Figure 32 shall be aimed photoelectrically during the photometric test in the manner prescribed in SAE Standard J584, OCT93, *Motorcycle Headlamps*.

S7.9.4 Motorcycle headlamp modulation system

S7.9.4.1 A headlamp on a motorcycle may be wired to modulate either the upper beam or the lower beam from its maximum intensity to a lesser intensity, provided that:

- (a) The rate of modulation shall be 240 ± 40 cycles per minute.
- (b) The headlamp shall be operated at maximum power for 50 to 70 percent of each cycle.
- (c) The lowest intensity at any test point shall be not less than 17 percent of the maximum intensity measured at the same point.
- (d) The modulator switch shall be wired in the power lead of the beam filament being modulated and not in the ground side of the circuit.
- (e) Means shall be provided so that both the lower beam and upper beam remain operable in the event of a modulator failure.
- (f) The system shall include a sensor mounted with the axis of its sensing element perpendicular to a horizontal plane. Headlamp modulation shall cease whenever the level of light emitted by a tungsten filament light operating at 3000 degrees Kelvin is either less than 270 lux (25 foot-candles) of direct light for upward pointing sensors or less than 60 lux (5.6 foot-candles) of reflected light for downward pointing sensors. The light is measured by a silicon cell type light meter that is located at the sensor and pointing in the same direction as the sensor. A Kodak Gray Card (Kodak R-27) is placed at ground level to simulate the road surface in testing downward pointing sensors.
- (g) When tested in accordance with the test profile shown in Figure 9, the voltage drop across the modulator when the lamp is on at all test conditions for 12 volt systems and 6 volt systems shall not be greater than 0.45 volt. The modulator shall meet all the provisions of this TSD ~~the standard~~ after completion of the test profile shown in Figure 9.
- (h) Means shall be provided so that both the lower and upper beam function at design voltage when the headlamp control switch is in either the lower or upper beam position when the modulator is off.

S7.9.4.2 [CONTENT DELETED]

S7.9.5 Each replaceable bulb headlamp that is designed to meet the photometric requirements of paragraph S7.9.1(a) or paragraph S7.9.2(a) and that is equipped with a light source other than a replaceable light source meeting the requirements of paragraph S7.7, shall have the word “motorcycle” permanently marked on the lens in characters not less than 3 mm (0.114 inch) in height.

S7.9.6 A headlamp system shall be installed on a motorcycle in accordance with the requirements of this paragraph.

S7.9.6.1 The headlamp system shall be located on the front of the motorcycle.

S7.9.6.2

- (a) If the system consists of a single headlamp, it shall be mounted on the vertical centerline of the motorcycle. If the headlamp contains more than one light source, each light source shall be mounted on the vertical centerline with the upper beam no higher than the lower beam, or horizontally disposed about the vertical centerline and mounted at the same height. If the light sources are horizontally disposed about the vertical centerline, the distance between the closest edges of the effective projected luminous lens area in front of the light sources shall not be greater than 200 mm (8 inches).
- (b) If the system consists of two headlamps, each of which provides both an upper and a lower beam, the headlamps shall be mounted either at the same height and symmetrically disposed about the vertical centerline or mounted on the vertical centerline. If the headlamps are horizontally disposed about the vertical centerline, the distance between the closest edges of their effective projected luminous lens areas shall not be greater than 200 mm (8 inches).
- (c) If the system consists of two headlamps, one of which provides an upper beam and one of which provides the lower beam, the headlamps shall be located on the vertical centerline with the upper beam no higher than the lower beam, or horizontally disposed about the vertical centerline and mounted at the same height. If the headlamps are horizontally disposed about the vertical centerline, the distance between the closest edges of their effective projected luminous lens areas shall not be greater than 200 mm (8 inches).

S8. Tests and procedures for integral beam and replaceable bulb headlighting systems

When tested in accordance with the following procedures, each integral beam headlamp shall meet the requirements of paragraph S7.4, and each replaceable bulb headlamp shall meet the requirements of paragraph S7.5. Ballasts required to operate specific gas mixture light sources shall be included in the tests specified in paragraphs S8.1 and S8.4 through S8.7.

S8.1 Photometry

Each headlamp to which paragraph S8 applies shall be tested according to paragraphs 4.1 and 4.1.4 of SAE Standard J1383 APR85 for meeting the applicable photometric requirements, after each test specified in paragraphs S8.2, S8.3, S8.5, S8.6.1, S8.6.2, S8.7, and S8.10.1 and S8.10.2, if applicable. A 0.25-degree reaim is permitted in any direction at any test point.

S8.2 Abrasion

- (a) A headlamp shall be mounted in the abrasion test fixture in the manner indicated in Figure 5 with the lens facing upward.
- (b) An abrading pad meeting the requirements in paragraphs (c)(1) through (c)(4) of this section shall be cycled back and forth (1 cycle) for 11 cycles at $10 \text{ cm} \pm 2 \text{ cm}$ (4 ± 0.8 inches) per second over at least 80 percent of the lens surface, including all the area between the upper and lower aiming pads, but not including lens trim rings and edges.
- (c)
 - (1) The abrading pad shall be not less than $2.5 \text{ cm} \pm 0.1 \text{ cm}$ (1.0 ± 0.04 inch) wide, constructed of 0000 steel wool, and rubber cemented to a rigid base shaped to the same vertical contour of the lens. The “grain” of the pad shall be perpendicular to the direction of motion.
 - (2) The abrading pad support shall be equal in size to the pad and the center of the support surface shall be within $\pm 2 \text{ mm}$ (± 0.08 inch) of parallel to the lens surface.
 - (3) The density of the abrading pad shall be such that, when the pad is mounted to its support and is resting unweighted on the lens, the base of the pad shall be no closer than 3.2 mm (0.125 inch) to the lens at its closest point.
 - (4) When mounted on its support and resting on the lens of the test headlamp, the abrading pad shall then be weighted such that a pad pressure of $14 \pm 1 \text{ kPa}$ (2.0 ± 0.15 psi) exists at the center and perpendicular to the face of the lens.
- (d) A pivot shall be used if it is required to follow the contour of the lens.
- (e) Unused steel wool shall be used for each test.

S8.3 Chemical resistance

- (a) The entire exterior lens surface of the headlamp in the headlamp test fixture and top surface of the lens-reflector joint shall be wiped once to the left and once to the right with a 15-cm (6-inch) square soft cotton cloth (with pressure equally applied) which has been saturated once in a container with 60 mL (2 ounces) of a test fluid as listed in paragraph (b). The lamp shall be wiped within 5 seconds after removal of the cloth from the test fluid.
- (b) The test fluids are:
 - (1) ASTM Reference Fuel C, which is composed of Isooctane 50% volume and Toluene 50% volume. Isooctane must conform to A2.7 in Annex 2 of the *Motor Fuels Section* of the *1985 Annual Book of ASTM Standards*, Vol. 05.04, and Toluene must conform to ASTM specification D362-84, *Standard Specification for Industrial Grade Toluene*. ASTM Reference Fuel C must be used as specified in:

- (i) Paragraph A2.3.2 and A2.3.3 of Annex 2 to *Motor Fuels, Section 1* in the *1985 Annual Book of ASTM Standards*; and
 - (ii) OSHA Standard 29 CFR 1910.106 - *Handling, Storage and Use of Flammable Combustible Liquids*.
- (2) Tar remover (consisting by volume of 45% xylene and 55% petroleum base mineral spirits).
 - (3) Power steering fluid (as specified by the vehicle manufacturer for use in the motor vehicle on which the headlamp is intended to be installed).
 - (4) Windshield washer fluid consisting of 0.5% monoethanolamine with the remainder 50% concentration of methanol/distilled water by volume.
 - (5) Antifreeze (50% concentration of ethylene glycol/distilled water by volume).
- (c) After the headlamp has been wiped with the test fluid, it shall be stored in its designed operating attitude for 48 hours at a temperature of 23 ± 4 degrees C (73 ± 7 degrees F) and a relative humidity of 30 ± 10 percent. At the end of the 48-hour period, the headlamp shall be wiped clean with a soft dry cotton cloth and visually inspected.

S8.4 Corrosion

- (a) A connector test shall be performed on each filament circuit prior to the test in subparagraph (b) according to Figure 1 ~~and~~ of SAE Standard J580 DEC86. The power source shall be set to provide 12.8 volts and the resistance shall be set to produce 10 amperes.
- (b) The headlamp with connector attached to the terminals, unfixtured and in its designed operating attitude with all drain holes, breathing devices, or other designed openings in their normal operating positions, shall be subjected to a salt spray (fog) test in accordance with ASTM B117-73, *Method of Salt Spray (Fog) Testing*, for 240 hours, consisting of ten successive 24-hour periods. During each period, the headlamp shall be mounted in the middle of the chamber and exposed for 23 hours to the salt spray. The spray shall not be activated during the 24th hour. The bulb shall be removed from the headlamp and from the test chamber during the one hour of salt spray deactivation and reinserted for the start of the next test period at the following times: at the end of the first and last three 23-hour periods of salt spray exposure and at the end of any two of the fourth through seventh 23-hour periods of salt-spray exposure. The test chamber shall be closed at all times, except for a maximum of 2 minutes which is allowed for removal or replacement of a bulb during each period. After the ten periods, the lens reflector unit without the bulb shall be immersed in deionized water for 5 minutes, then secured and allowed to dry by natural convection only.
- (c) Using the voltage, resistance, and pretest set up of paragraph (a), the current in each filament circuit shall be measured after the test conducted in paragraph (b).

S8.5 Dust

The headlamp, mounted on a headlamp test fixture, with all drain holes, breathing devices, or other designed openings in their normal operating positions, shall be positioned within a cubical box with inside measurements of 900 mm (35.4 inches) on each side or larger, if required for adequate wall clearance, i.e., a distance of at least 150 mm (5.9 inches) between the headlamp and any wall of the box. The box shall contain 4.5 kg (9.9 pounds) of fine powdered cement which conforms to the ASTM C150-77 specification for Portland Cement. Every 15 minutes, the cement shall be agitated by compressed air or fan blower(s) by projecting blasts of air for a two-second period in a downward direction so that the cement is diffused as uniformly as possible throughout the entire box. This test shall be continued for five hours, after which the exterior surfaces of the headlamp shall be wiped clean.

S8.6 Temperature and internal heat test

A headlamp with one or more replaceable light sources shall be tested according to paragraphs S8.6.1 and S8.6.2. Tests shall be made with all filaments lighted at design voltage that are intended to be used simultaneously in the headlamp and which in combination draw the highest total wattage. These include, but are not limited to, filaments used for turn signal lamps, fog lamps, parking lamps, and headlamp lower beams lighted with upper beams when the wiring harness is so connected on the vehicle. If a turn signal is included in the headlamp assembly, it shall be operated at 90 flashes a minute with a $75 \pm 2\%$ current "on time". If the lamp produces both the upper and lower beam, it shall be tested in both the upper beam mode and the lower beam mode under the conditions above described, except for a headlamp with a single Type HB1 or HB2 light source.

S8.6.1 Temperature cycle. A headlamp, mounted on a headlamp test fixture, shall be subjected to 10 complete consecutive cycles having the thermal cycle profile shown in Figure 6. During the hot cycle, the lamp shall be energized commencing at point "A" of Figure 6 and de-energized at point "B". Separate or single test chambers may be used to generate the environments of Figure 6. All drain holes, breathing devices, or other openings or vents of the headlamps shall be in their normal operating positions.

S8.6.2 Internal heat test

- (a) The headlamp lens surface that would normally be exposed to road dirt shall be uniformly sprayed with any appropriate mixture of dust and water or other materials to reduce the photometric output at the H-V test point of the upper beam (or the $\frac{1}{2}D-1\frac{1}{2}R$ test point of the lower beam, as appropriate) to $25 \pm 2\%$ of the output originally measured in the photometric test conducted pursuant to paragraphs S7.4(i) or S7.5(a) through (e), as applicable. A headlamp with a single Type HB1 or HB2 light source shall be tested on the upper beam only. Such reduction shall be determined under the same conditions as ~~that of~~ the original photometric measurement.
- (b) After the photometric output of the lamp has been reduced as specified in paragraph (a), the lamp and its mounting hardware shall be mounted in an environmental chamber in a manner similar to that indicated in Figure 7

“Dirt/Ambient Test Setup”. The headlamp shall be soaked for one hour at a temperature of $35 + 4 - 0$ degrees C ($95 + 7 - 0$ degrees F) and then the lamp shall be energized according to paragraph S8.6 for one hour in a still air condition, allowing the temperature to rise from the soak temperature.

- (c) The lamp shall be returned to a room ambient temperature of $23 + 4 - 0$ degrees C ($73 + 7 - 0$ degrees F) and a relative humidity of $30 \pm 10\%$ and allowed to stabilize to the room ambient temperature. The lens shall then be cleaned.

S8.7 Humidity

- (a) The test fixture consists of a horizontal steel plate to which three threaded steel or aluminum rods of 12.5 mm (0.5 inch) diameter are screwed vertically behind the headlamp. The headlamp assembly is clamped to the vertical rods, which are behind the headlamp. All attachments to the headlamp assembly are made behind the lens and vents or openings and are not within 50 mm (2 inches) laterally of a vent inlet or outlet.
- (b) The mounted headlamp assembly is oriented in its design operating position, and is placed in a controlled environment at a temperature of $38 + 4 - 0$ degrees C ($100 + 7 - 0$ degrees F) with a relative humidity of not less than 90 percent. All drain holes, breathing devices, and other openings are in their normal operation positions for all phases of the humidity test. The headlamp shall be subjected to 24 consecutive 3-hour test cycles. In each cycle, it shall be energized for 1 hour at design voltage with the highest combination of filament wattages that are intended to be used, and then de-energized for 2 hours. If the headlamp incorporates a turn signal, it shall flash at 90 flashes per minute with a $75 \pm 2\%$ current “on-time”.
- (c) Within 3 minutes after the completion of the 24th cycle, the air flow test will begin. The following shall occur: The mounted assembly shall be removed, placed in an insulating box, and covered with foam material so that there is no visible air space around the assembly; the box shall be closed, taken to the air flow test chamber, and placed within it. Inside the chamber, the assembly with respect to the air flow, shall be oriented in its design operating position. The assembly is positioned in the chamber so that the center of the lens is in the center of the opening of the air flow entry duct during the test. The headlamp has at least 76 mm (3 inches) clearance on all sides, and at least 102 mm (4 inches) to the entry and exit ducts at the closest points. If vent tubes are used which extend below the lamp body, the 76 mm (3 inches) are measured from the bottom of the vent tube or its protection. The temperature of the chamber is $23 + 4 - 0$ degrees C ($73 + 7 - 0$ degrees F) with a relative humidity of $30 + 10 - 0$ percent. The headlamp is not energized.
- (d) Before the test specified in paragraph (e) of this section, the uniformity of the air flow in the empty test chamber at a plane 102 mm (4 inches) downstream of the air entry duct shall have been measured over a 102-mm (4-inch) square grid. The uniformity of air flow at each grid point is ± 10 percent of the average air flow specified in paragraph (e) of this section.

- (e) The mounted assembly in the chamber shall be exposed for one hour to an average air flow of $1.7 + 0 - 0.15$ m/s (330 + 0 - 30 ft/min.), as measured with an air velocity measuring probe having an accuracy of ± 3 percent in the 1.7 m/s (330 ft/min.) range. The average air flow is the average of the velocity recorded at six points around the perimeter of the lens. The six points are determined as follows: At the center of the lens, construct a horizontal plane. The first two points are located in the plane, 25 mm (1 inch) outward from the intersection of the plane and each edge of the lens. Then, trisect the distance between these two points and construct longitudinal vertical planes at the two intermediate locations formed by the trisection. The four remaining points are located in the vertical planes 25 mm (one inch) above the top edge of the lens and 25 mm (one inch) below the bottom edge of the lens.
- (f) After one hour, the headlamp is removed and inspected for moisture.

S8.8 Vibration

A vibration test shall be conducted in accordance with the procedures of SAE Standard J575e, *Tests for Motor Vehicle Lighting Devices and Components*, August 1970, and the following: the table on the adapter plate shall be of sufficient size to completely contain the test fixture base with no overhang. The vibration shall be applied in the vertical axis of the headlamp system as mounted on the vehicle. The filament shall not be energized.

S8.9 Sealing

An unfixtured headlamp in its design mounting position shall be placed in water at a temperature of 80 ± 3 degrees C (176 ± 5 degrees F) for one hour. The headlamp shall be energized in its highest wattage mode, with the test voltage at 12.8 ± 0.1 V during immersion. The lamp shall then be de-energized and immediately submerged in its design mounting position into water at $0 + 3 - 0$ degrees C ($32 + 5 - 0$ degrees F). The water shall be in a pressurized vessel, and the pressure shall be increased to 70 kPa (10 psi) upon placing the lamp in the water. The lamp shall remain in the pressurized vessel for a period of thirty minutes. This entire procedure shall be repeated for four cycles. Then the lamp shall be inspected for any signs of water on its interior. During the high temperature portion of the cycles, the lamp shall be observed for signs of air escaping from its interior. If any water occurs on the interior or air escapes, the lamp is not a sealed lamp.

S8.10 Chemical and corrosion resistance of reflectors of replaceable lens headlamps

S8.10.1 Chemical resistance

- (a) With the headlamp in the headlamp test fixture and the lens removed, the entire surface of the reflector that receives light from a headlamp light source shall be wiped once to the left and once to the right with a 152 -mm (6-inch) square soft cotton cloth (with pressure equally applied) which has been saturated once in a container with 60 mL (2 ounces) of one of the test fluids listed in paragraph (b). The lamp shall be wiped within 5 seconds after removal of the cloth from the test fluid.

- (b) The test fluids are:
- (1) Tar remover (consisting by volume of 45% xylene and 55% petroleum base mineral spirits);
 - (2) Mineral spirits; or
 - (3) Fluids other than water contained in the manufacturer's instructions for cleaning the reflector.
- (c) After the headlamp has been wiped with the test fluid, it shall be stored in its designed operating attitude for 48 hours at a temperature of 23 ± 4 degrees C (73 ± 7 degrees F) and a relative humidity of 30 ± 10 percent. At the end of the 48-hour period, the headlamp shall be wiped clean with a soft dry cotton cloth and visually inspected.

S8.10.2 Corrosion

- (a) The headlamp with the lens removed, unfixtured and in its designed operating attitude with all drain holes, breathing devices or other designed openings in their normal operating positions, shall be subjected to a salt spray (fog) test in accordance with ASTM B117-73, *Method of Salt Spray (Fog) Testing*, for 24 hours, while mounted in the middle of the chamber.
- (b) Afterwards, the headlamp shall be stored in its designed operating attitude for 48 hours at a temperature of 23 ± 4 degrees C (73 ± 7 degrees F) and a relative humidity of 30 ± 10 percent and allowed to dry by natural convection only. At the end of the 48-hour period, the reflector shall be cleaned according to the instructions supplied with the headlamp manufacturer's replacement lens, and inspected. The lens and seal shall then be attached according to these instructions and the headlamp tested for photometric performance.

S9. Deflection test for replaceable light sources

(39)

With the light source rigidly mounted in a fixture in a manner indicated in Figure 8, a force 17.8 ± 0.4 N (4.0 ± 0.1 pounds) is applied at a distance "A" from the reference plane perpendicular to the longitudinal axis of the glass capsule and parallel to the smallest dimension of the pressed glass capsule seal. The force shall be applied [using a rod with a hard rubber tip with a minimum spherical radius of 1 mm (0.039 in)] radially to the surface of the glass capsule in four locations in a plane parallel to the reference plane and spaced at a distance "A" from that plane. These force applications shall be spaced 90 degrees apart starting at the point perpendicular to the smallest dimension of the pressed seal of the glass capsule. The bulb deflection shall be measured at the glass capsule surface at 180 degrees opposite to the force application. Distance "A" for a replaceable light source other than an HB Type shall be the dimension specified or supplied in accordance with subsection 108(5) of the MVSR provided in accordance with Appendix A of part 564 of this chapter, section I.A.1 if the light source has a lower beam filament, or as specified in section I.B.1 if the light source has only an upper beam filament.

(50) **S10. Simultaneous aim photometry tests**

- (a) *Type F headlamp systems.* The assembly shall be located on a goniometer placed not less than 18.3 m (60 feet) from the photometer. The LF unit shall be aimed mechanically by centering the unit on the photometer axis and by aligning the aiming plane of the lens perpendicular to the photometer axis. Then the assembly shall be moved in a plane parallel to the established aiming plane of the LF headlamp until the UF headlamp is centered on the photometer axis. Photometry measurements of the UF photometry unit shall be completed using the aiming plane so established, and the procedures of sections 4.1 and 4.1.4 of SAE Standard J1383 APR85, and Figure 15-1 or Figure 15-2. A reaim tolerance of ± 0.25 degree is permitted in any direction at any test point.
- (b) *Integral beam headlamp systems.* The assembly used for simultaneously aiming more than one integral beam headlamp shall be placed on a test fixture on a goniometer located not less than 18.3 m (60 feet) from the photometer. The assembly shall be aimed by centering the geometric center of the lower beam lens(es) on the photometer axis and by aligning the photometer axis to be perpendicular to the aiming reference plane or appropriate vertical plane defined by the manufacturer of any lower beam contributor. Photometric compliance of the lower beam shall be determined with all lower beam contributors illuminated and in accordance with sections 4.1 and 4.1.6 of SAE Standard J1383 APR85, and Figure 15-1 or Figure 15-2. The assembly shall then be moved in a plane parallel to the established aiming plane of the lower beam until the assembly is located with the geometric center of the upper beam lens(es) on the photometer axis. Photometric compliance for the upper beam shall now be determined using the figure and procedure specified for the lower beam. During photometric testing, a 0.25-degree reaim is permitted in any direction at any test point.

(20) **S11. Photometric test**

- (48) A daytime running lamp that is wired in accordance with subsections 108(44) to (65) of the
- (49) MVSR paragraph S5.5.11 of this standard, shall be tested for compliance with subsection 108(48) S5.5.11(a)(1) in accordance with the test method specified for photometric testing in SAE Standard J575 DEC88 when a test voltage of $12.8V \pm 20$ mV is applied to the input terminals of the lamp switch module or voltage-reducing equipment, whichever is closer to the electrical source on the vehicle. The test distance from the lamp to the photometer shall be not less than 18.3 m, if the lamp is optically combined with a headlamp or is a separate lamp, and not less than 3 m, if the lamp is optically combined with a lamp, other than a headlamp, that is required by this TSD standard.

S12. Headlamp Concealment Devices

S12.1 While the headlamp is illuminated, its fully opened headlamp concealment device shall remain fully opened should any loss of power to or within the headlamp concealment device occur.

S12.2 Whenever any malfunction occurs in a component that controls or conducts power for the actuation of the concealment device, each closed headlamp concealment device shall be capable of being fully opened by a means not requiring the use of any tools. Thereafter, the headlamp concealment device must remain fully opened until intentionally closed.

S12.3 Except for malfunctions covered by S12.2, each headlamp concealment device shall be capable of being fully opened and the headlamps illuminated by actuation of a single switch, lever, or similar mechanism, including a mechanism that is automatically actuated by a change in ambient light conditions.

S12.4 Each headlamp concealment device shall be installed so that the headlamp may be mounted, aimed, and adjusted without removing any component of the device, other than components of the headlamp assembly.

S12.5 Except for cases of malfunction covered by S12.2, each headlamp concealment device shall, within an ambient temperature range of -28.9 degrees C (-20 degrees F) to +48.9 degrees C (+120 degrees F), be capable of being fully opened in not more than 3 seconds after the actuation of a driver-operated control.

S12.6 As an alternative to complying with the requirements of S12.1 through S12.5, a vehicle with headlamps incorporating VHAD or visual/optical aiming in accordance with paragraph S7 may meet the requirements for Concealable lamps in paragraph 5.14 of the following version of the Economic Commission for Europe Regulation 48 "Uniform Provisions Concerning the Approval of Vehicles With Regard to the Installation of Lighting and Light-Signalling Devices": E/ECE/324-E/ECE/TRANS/505, Rev.1/Add.47/Rev.1/Corr.2, 26 February 1996 (page 17), in the English language version. A copy of paragraph 5.14 may be reviewed at the DOT Docket Management Facility, U.S. Department of Transportation, Room PL-01, 400 Seventh Street, SW., Washington, D.C. 20590-0001. Copies of E/ECE/324-E/ECE/TRANS/505, Rev.1/Add.47/Rev.1/Corr.2, 26 February 1996 may be obtained from the ECE internet site: www.unece.org/trans/main/wp29/wp29regs.html or by writing to: United Nations, Conference Services Division, Distribution and Sales Section, Office C.115-1, Palais des Nations, CH-1211, Geneva 10, Switzerland.

S12.7 [CONTENT DELETED]

FIGURES AND TABLES TO TSD No. 108 ~~§571.108~~

FIGURES: 1A, 1B, 1C, 2, 4-1 to 4-4, 5 to 10, 15-1, 15-2, 17-1, 17-2, 19, 20, and 25 to 32

TABLES: I to IV

- (3) **Note:** Figures 11 through 14, 16, 18, 21, and 22 of Safety Standard No. 108 of the U.S. *Code of Federal Regulations* have been deleted.

**Figure 1A: Required Percentages of Minimum Candlepower
of Figure 1B**

Test Points (degrees)		Turn Signal	Stop	Parking	Tail
10U, 10D	5L, 5R	20	20	20	20
5U, 5D	20L, 20R	12.5	12.5	10	15
5U, 5D	10L, 10R	37.5	37.5	20	40
5U, 5D	V	87.5	87.5	70	90
H	10L, 10R	50	50	35	40
H	5L, 5R	100	100	90	100
H	V	100	100	100	100

Note: Minimum design candlepower requirements are determined by multiplying the percentages given in this Figure by the minimum allowable candlepower values in Figure 1B. The resulting values shall be truncated after one digit to the right of the decimal point.

Figure 1B: Minimum and Maximum Allowable Candlepower Values

Lamp	Lighted Sections		
	1	2	3
Stop	80/300	95/360	110/420
Tail ¹	2/18	3.5/20	5.0/25
Parking ²	4.0/125	--	--
Red Turn Signal	80/300	95/360	110/420
Yellow Turn Signal, Rear	130/750	150/900	175/1050
Yellow Turn Signal, Front	200/-	240/-	275/-
Yellow Turn Signal, Front ³	500/-	600/-	685/-

¹ Maximum at H or above.

² The maximum candlepower value of 125 applies to all test points at H or above. The maximum allowable candlepower value below H is 250.

³ Values apply when the optical axis (filament center) of the front turn signal is at a spacing less than 10 cm (4 inches) from the lighted edge of the headlamp unit providing the lower beam, or from the lighted edge of any additional lamp installed as original equipment and which supplements the lower beam.

Note: D means down; H means horizontal; L means left; R means right; U means up; and V means vertical.

Figure 1C: Sum of the Percentages of Grouped Minimum Candlepower

Group and Test Points	Turn Signal	Stop	Parking	Tail
1 10U-5L, 5U-20L, 5D-20L, 10D-5L	65	65	60	70
2 5U-10L, H-10L, 5D-10L	125	125	75	120
3 H-5L, 5U-V, H-V, 5D-V, H-5R	475	475	420	480
4 5U-10R, H-10R, 5D-10R	125	125	75	120
5 10U-5R, 5U-20R, 5D-20R, 10D-5R	65	65	60	70

Figure 2: Minimum Luminous Intensity Requirements for Backup Lamps

Group	Test Point (degrees)	Total for Group, (candela) ¹
1 ¹	45L-5U, 45L-H, 45L-5D	45
2 ¹	30L-H, 30L-5D	50
3	10L-10U, 10L-5U, V-10U, V-5U, 10R-10U, 10R-5U	100
4	10L-H, 10L-5D, V-H, V-5D, 10R-H, 10R-5D	360
5 ¹	30R-H, 30R-5D	50
6 ¹	45R-5U, 45R-H, 45R-5D	45

¹ When 2 lamps of the same or symmetrically opposite design are used, the reading along the vertical axis and the averages of the readings for the same angles left and right of vertical for 1 lamp shall be used to determine compliance with the requirements. If 2 lamps of differing designs are used, they shall be tested individually and the values added to determine that the combined units meet twice the candela requirements.

When only 1 backup lamp is used on the vehicle, it shall be tested to twice the candela requirements.

Note: D means down; H means horizontal; L means left; R means right; U means up; and V means vertical.

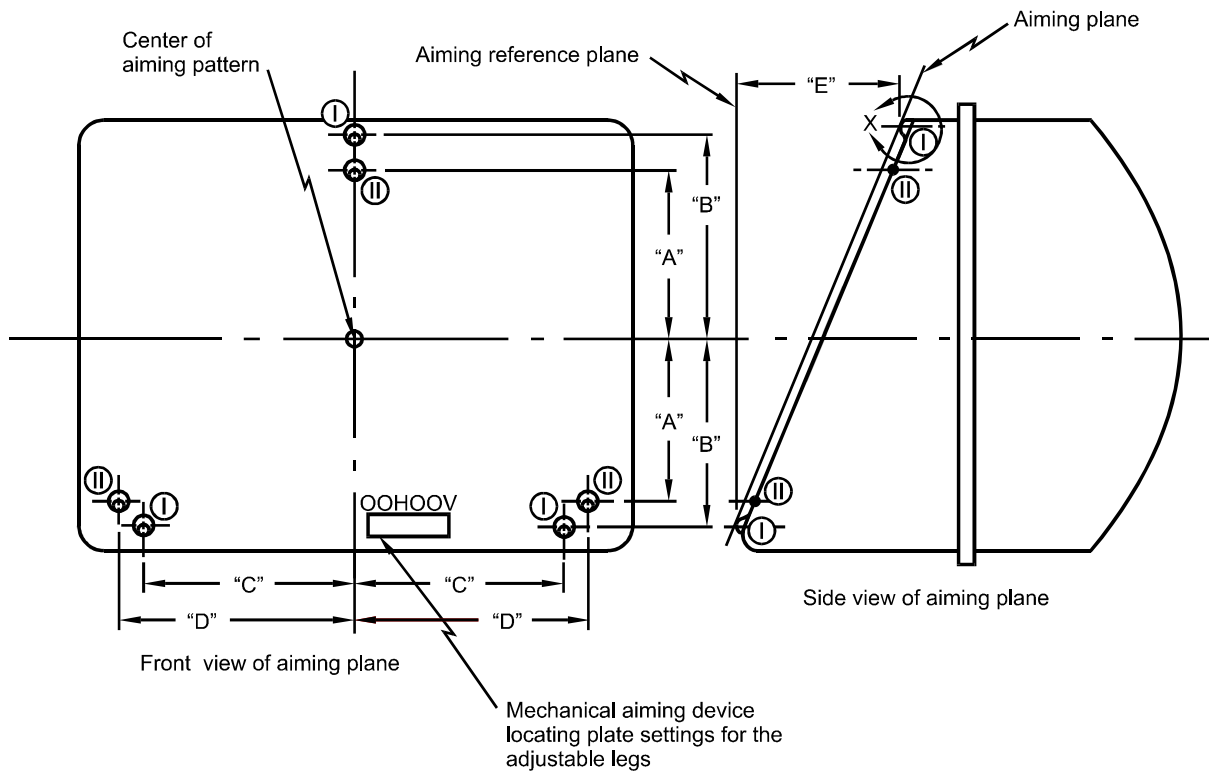

Figure 4-1: Dimensional Specifications for Location of Aiming Pads on Replaceable Bulb Headlamp Units

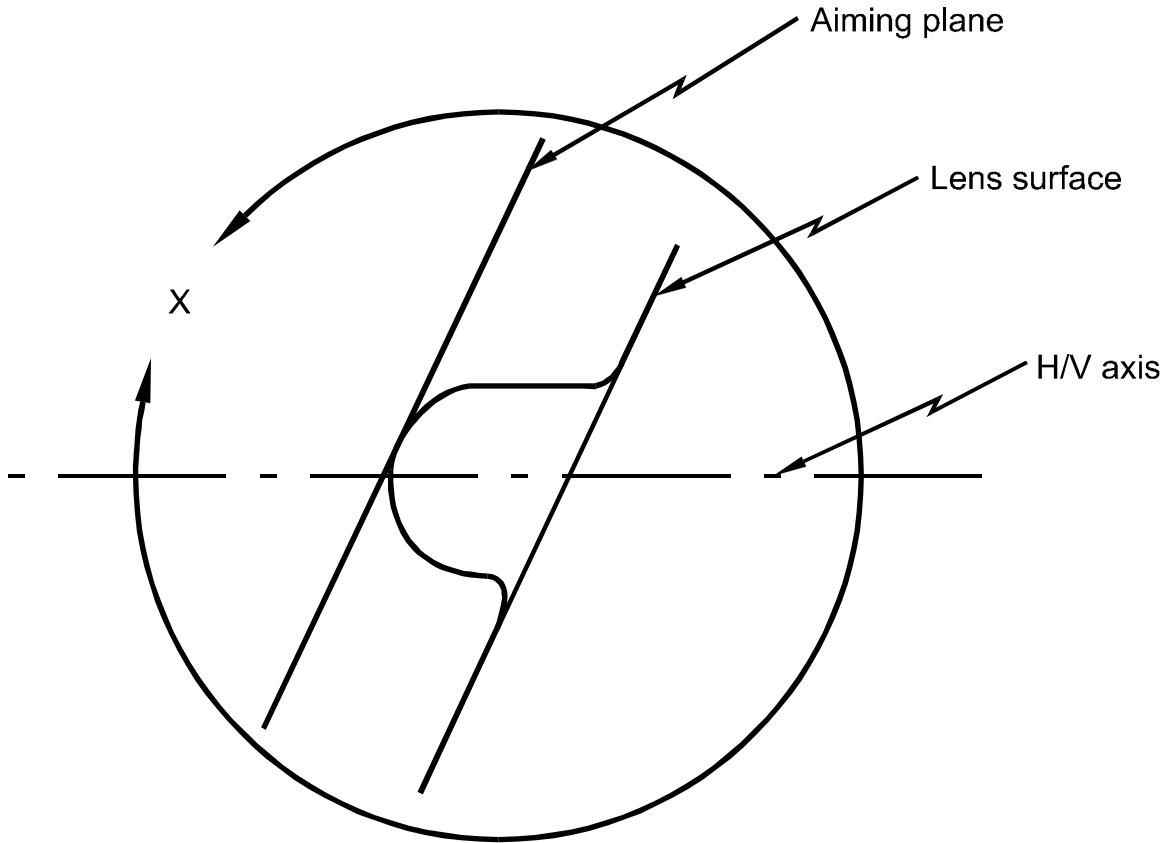
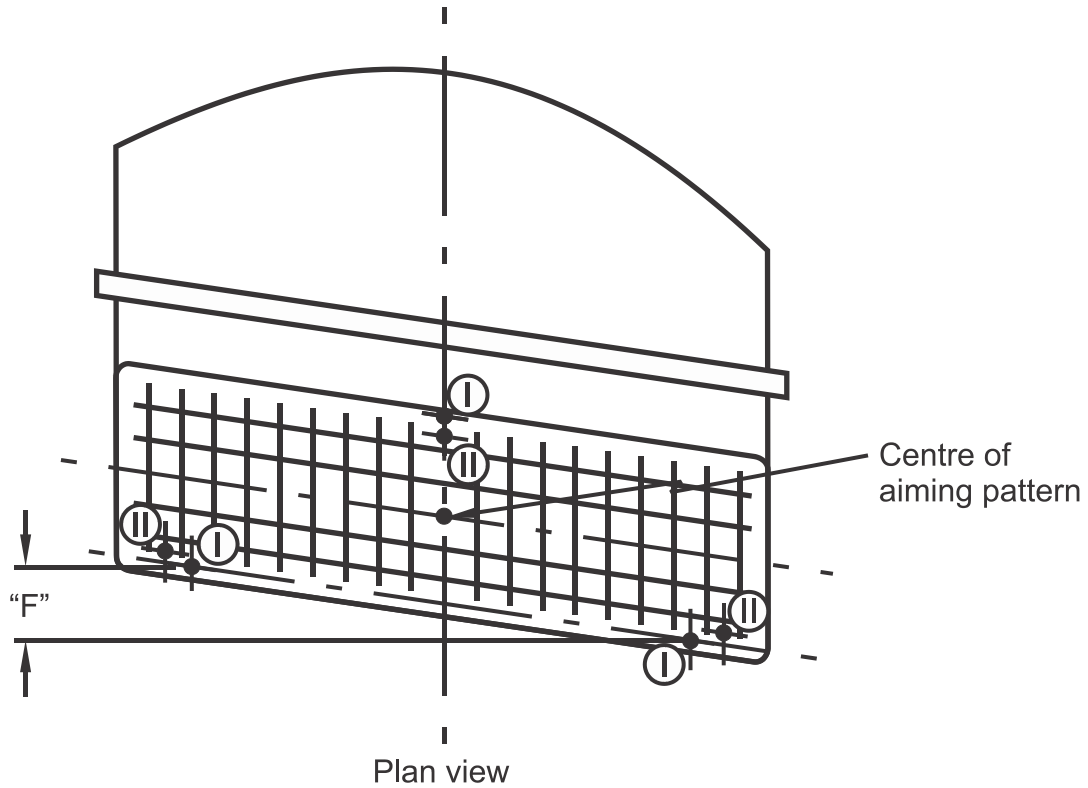

Figure 4-2: Detailed Example of Aiming Pad



Notes:

1. Group I or Group II aiming pad locations may be used.
2. Group I aiming pad location (front view) is that prescribed for 2B1 sealed beam units.
3. Group II aiming pad location (front view) is that prescribed for 1A1 and 2A1 sealed beam units.

Figure 4-3: Dimensional Specifications for Location of Aiming Pads on Replaceable Bulb Units

Figure 4-4: Dimensional Specifications for Location of Aiming Pads on Replaceable Bulb Units

<u>Dimension</u>	<u>Millimeters</u>	<u>Inches</u>
A	42.16 ± 0.25	1.660 ± 0.010
B	60.05 ± 1.00	2.364 ± 0.039
C	64.0 ± 1.00	2.520 ± 0.039
D	68.58 ± 0.51	2.700 ± 0.020
E	Mechanical aiming device locating plate setting for the vertical adjustable leg. (Millimeters)	
F	Mechanical aiming device locating plate setting for the horizontal adjustable leg. (Millimeters)	

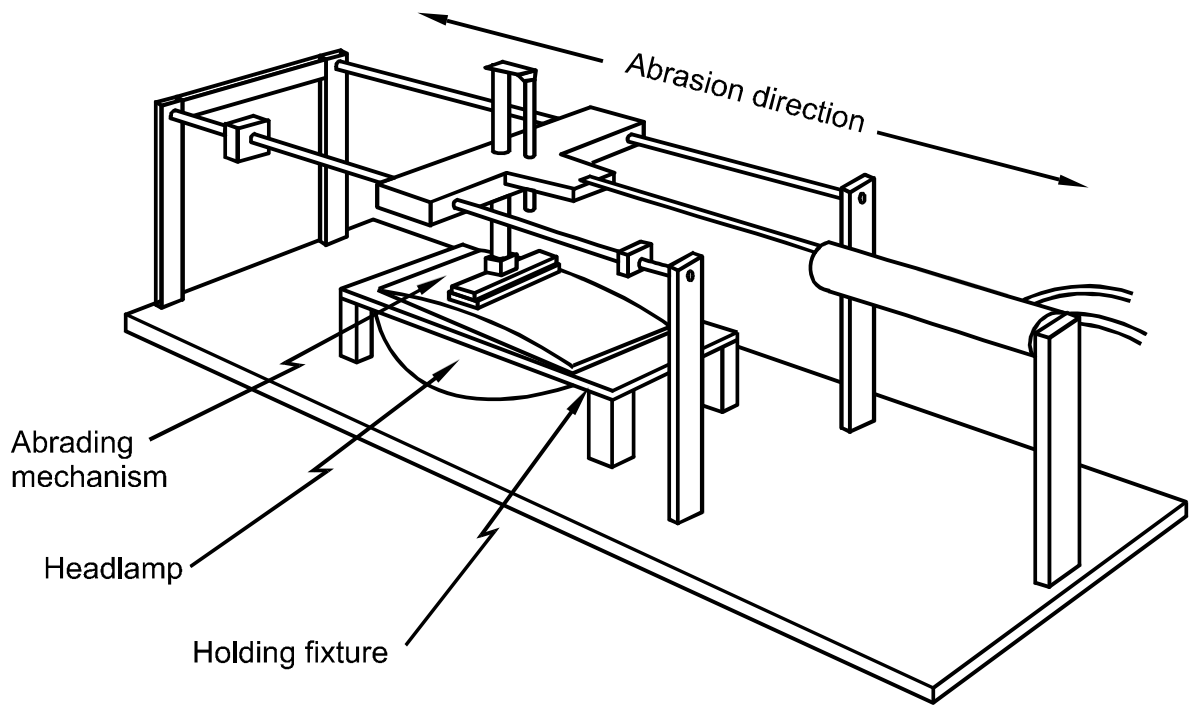
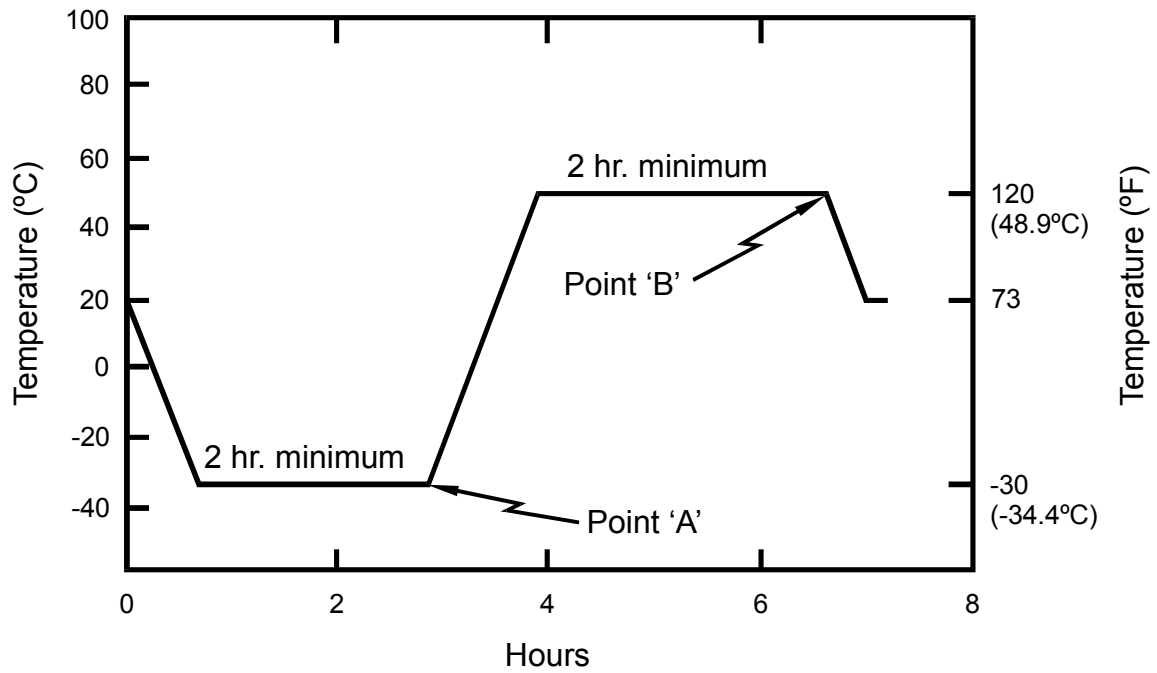

Figure 5: Abrasion Test Fixture

AMBIENT TEMPERATURE TRANSITION RATES:
Minimum 0.6°C (1°F) per minute
Maximum 4°C (8°F) per minute



Note:
Ambient conditions 23°C ± 4° (73°F ± 7°) and 30 ± 10% RH

Figure 6: Thermal Cycle Profile

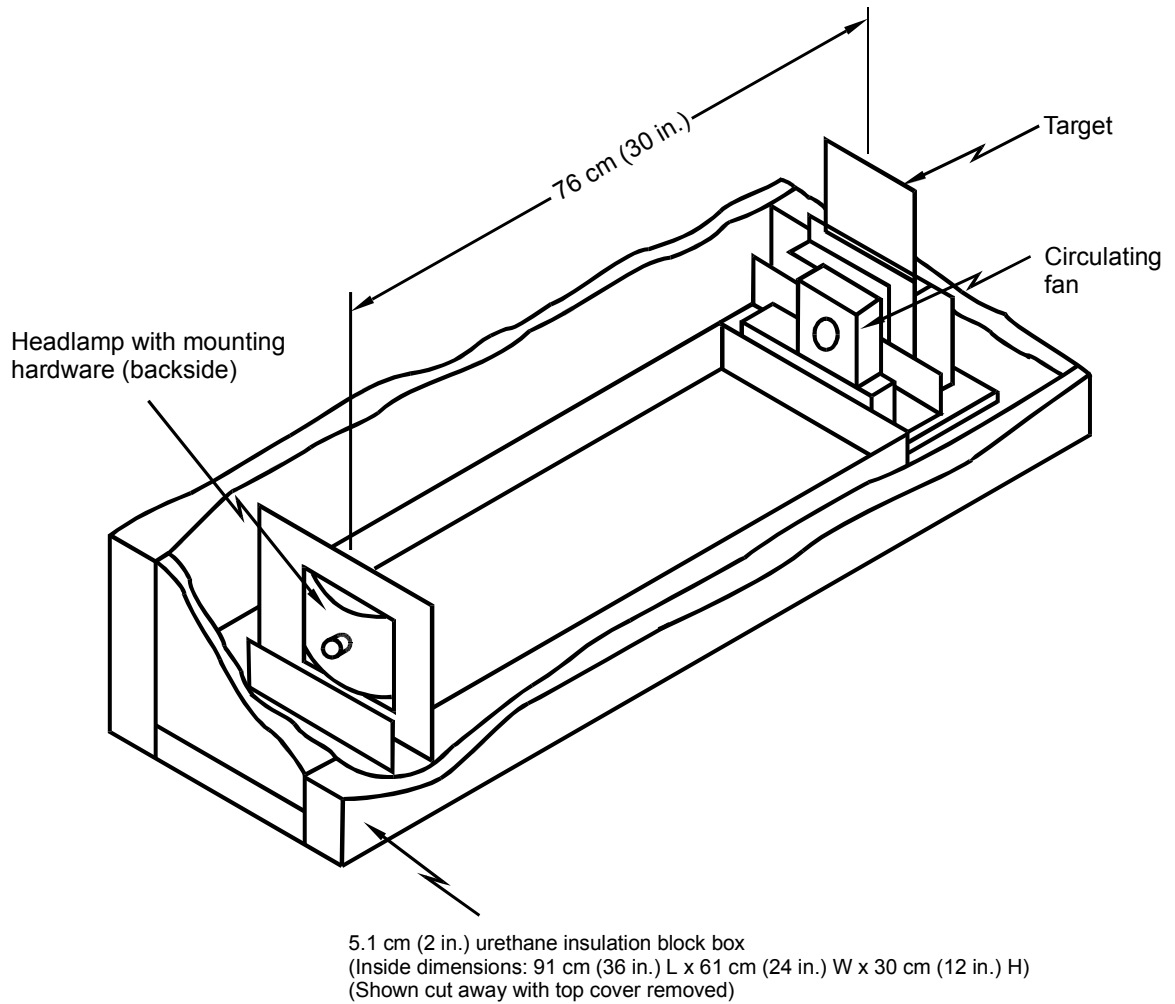

Figure 7: Dirt/Ambient Test Setup

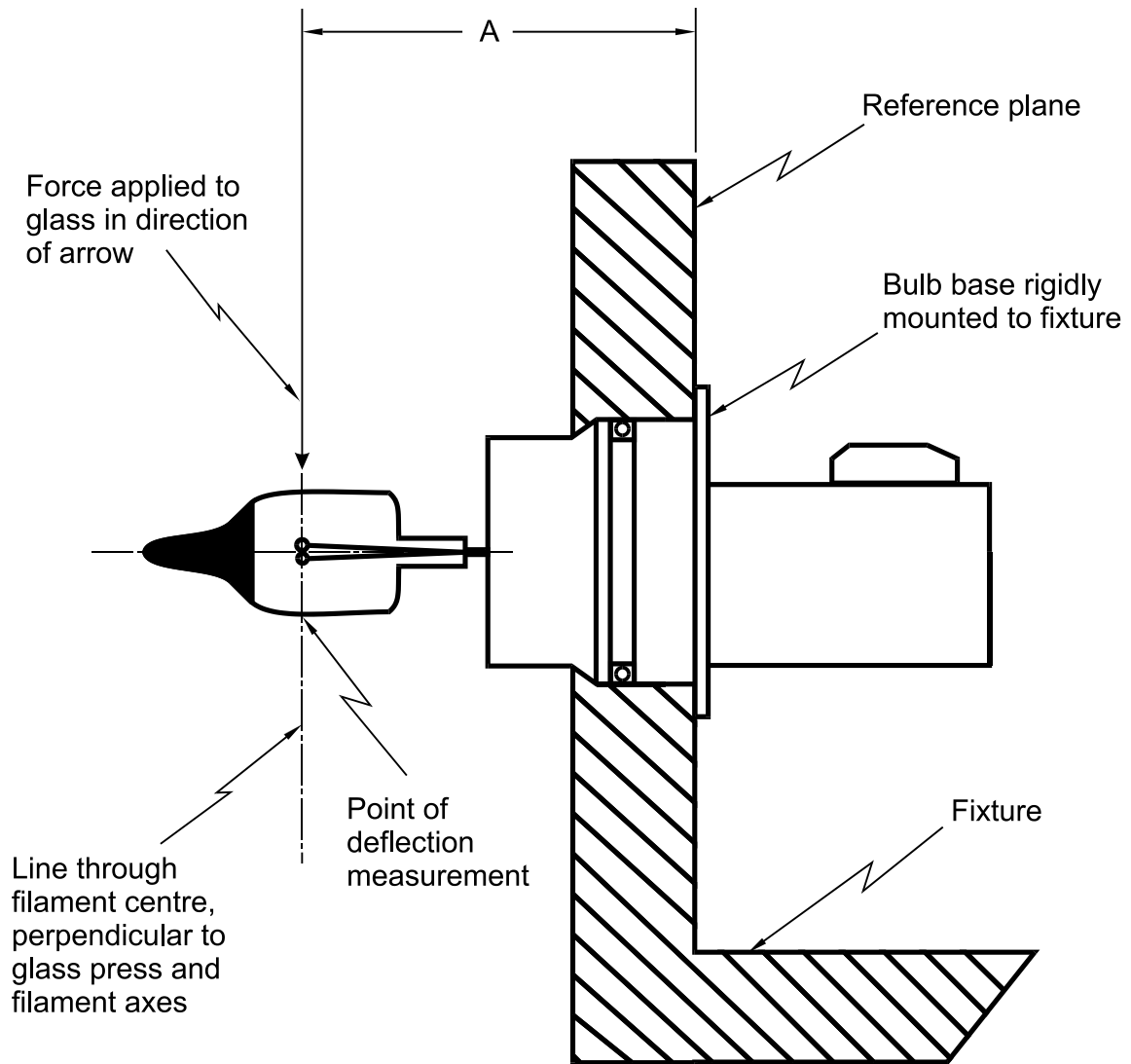
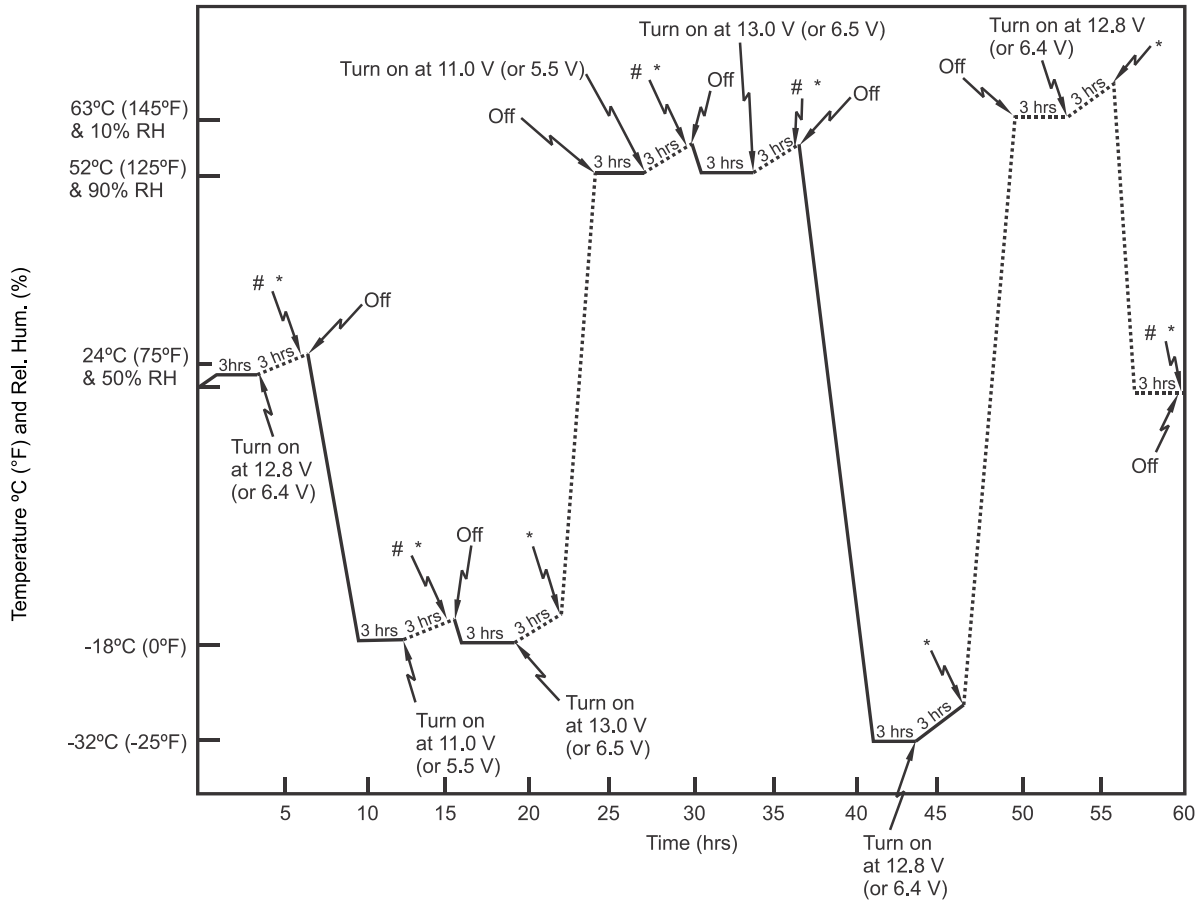

Figure 8: Bulb Deflection Test



Notes:

1. * Conduct voltage drop & rate test.
2. Environmental conditions shall not be altered after the test item is turned on.
3. Tolerances - Rate of temperature transition:
 Minimum: 0.6°C (1°F)/min.
 Maximum: 4°C (8°F)/min.
 Humidity: $\pm 5\%$ RH
 Soak temp: $\pm 3^\circ\text{C}$ ($\pm 5^\circ\text{F}$)
4. # Test of automatic Turn-off

Figure 9: Temperature-Humidity Environmental Test Profile

(15)

Figure 10: Photometric Requirements for Center High-Mounted Stop Lamps

Individual Test Points	Minimum Intensity (candela)	Zones (Test Points within Zone, See Note 2)	Minimum Total for Zone (candela)
10U-10L	8	Zone I (5U-V, H-5L, H-V, H-5R, 5D-V)	125
10U-V	16		
10U-10R	8		
5U-10L	16	Zone II (5U-5R, 5U-10R, H-10R, 5D-10R, 5D-5R)	98
5U-5L	25		
5U -V	25		
5U-5R	25		
5U-10R	16		
5D-10L	16	Zone III (5U-5L, 5U-10L, H-10L, 5D-10L, 5D-5L)	98
5D-5L	25		
5D-V	25		
5D-5R	25		
5D-10R	16		
H-10L	16	Zone IV (10U-10L, 10U-V, 10U-10R)	32
H-5L	25		
H-V	25		
H-5R	25		
H-10R	16		
See Note 1	160 ¹		

Note 1: The listed maximum shall not occur over any area larger than that generated by a 0.25-degree radius within a solid cone angle within the rectangle bounded by test points 10U-10L, 10U-10R, 5D-10L, and 5D-10R.

Note 2: The measured values at each test point shall not be less than 60% of the value listed.

Note 3: D means down; H means horizontal; L means left; R means right; U means up; and V means vertical.

¹ Maximum intensity (Candela)

Figure 15-1: Photometric Test Point Values for Mechanical Aim Headlighting Systems**Four-Lamp Systems****UPPER BEAM**

Test Points (degrees)	Candela Maximum	Candela Minimum
2U-V		1,500
1U-3L and 3R		5,000
H-V	70,000	40,000
H-3L and 3R		15,000
H-6L and 6R		5,000
H-9L and 9R		3,000
H-12L and 12R		1,500
1.5D-V		5,000
1.5D-9L and 9R		2,000
2.5D-V		2,500
2.5D-12L and 12R		1,000
4D-V	5,000	

LOWER BEAM

Test Points (degrees)	Candela Maximum	Candela Minimum
10U-90U	125	
4U-8L and 8R		64
2U-4L		135
1.5U-1R to 3R		200
1.5U-1R to R	1,400	
1U-1.5L to L	700	
0.5U-1.5L to L	1,000	
0.5U-1R to 3R	2,700	500
H-4L		135
H-8L		64
0.5D-1.5L to L	3,000	
0.5D-1.5R	20,000	10,000
1D-6L		1,000
1.5D-2R		15,000
1.5D-9L and 9R		1,000
2D-15L and 15R		850
4D-4R	12,500	
4D-V	7,000	
H-V	5,000	

Note: D means down; H means horizontal; L means left; R means right; U means up; and V means vertical.

**Figure 15-2: Photometric Test Point Values for
Visual/Optical Aim Headlighting Systems**

Four-Lamp Systems

UPPER BEAM

Test Points (degrees)	Candela Maximum	Candela Minimum
2U-V		1,500
1U-3L and 3R		5,000
H-V	70,000	40,000
H-3L and 3R		15,000
H-6L and 6R		5,000
H-9L and 9R		3,000
H-12L and 12R		1,500
1.5D-V		5,000
1.5D-9L and 9R		2,000
2.5D-V		2,500
2.5D-12L and 12R		1,000
4D-V	5,000	

LOWER BEAM

Test Points (degrees)	Candela Maximum	Candela Minimum
10U-90U	125	
4U-8L and 8R		64
2U-4L		135
1.5U-1R to 3R		200
1.5U-1R to R	1,400	
1U-1.5L to L	700	
0.5U-1.5L to L	1,000	
0.5U-1R to 3R	2,700	500
H-V	5,000	
H-4L		135
H-8L		64
0.6D-1.3R		10,000
0.86D-V		4,500
0.86D-3.5L	12,000	1,800
1.5D-2R		15,000
2D-9L and 9R		1,250
2D-15L and 15R		1,000
4D-V	10,000	
4D-4R	12,500	
4D-20L and 20R		300

Note: D means down; H means horizontal; L means left; R means right; U means up; and V means vertical.

Figure 17-1: Photometric Test Point Values for Mechanical Aim Headlighting Systems

Two-Lamp Systems

UPPER BEAM

Test Points (degrees)	Candela Maximum	Candela Minimum
2U-V		1,500
1U-3L and 3R		5,000
H-V	75,000	40,000
H-3L and 3R		15,000
H-6L and 6R		5,000
H-9L and 9R		3,000
H-12L and 12R		1,500
1.5D-V		5,000
1.5D-9L and 9R		2,000
2.5D-V		2,500
2.5D-12L and 12R		1,000
4D-V	12,000	

LOWER BEAM

Test Points (degrees)	Candela Maximum	Candela Minimum
10U-90U	125	
4U-8L and 8R		64
2U-4L		135
1.5U-1R to 3R		200
1.5U-1R to R	1,400	
1U-1.5L to L	700	
0.5U-1.5L to L	1,000	
0.5U-1R to 3R	2,700	500
H-4L		135
H-8L		64
0.5D-1.5L to L	3,000	
0.5D-1.5R	20,000	10,000
1D-6L		1,000
1.5D-2R		15,000
1.5D-9L and 9R		1,000
2D-15L and 15R		850
4D-4R	12,500	

Note: D means down; H means horizontal; L means left; R means right; U means up; and V means vertical.

**Figure 17-2: Photometric Test Point Values for
Visual/Optical Aim Headlighting Systems**

Two-Lamp Systems

UPPER BEAM

Test Points (degrees)	Candela Maximum	Candela Minimum
2U-V		1,500
1U-3L and 3R		5,000
H-V	75,000	40,000
H-3L and 3R		15,000
H-6L and 6R		5,000
H-9L and 9R		3,000
H-12L and 12R		1,500
1.5D-V		5,000
1.5D-9L and 9R		2,000
2.5D-V		2,500
2.5D-12L and 12R		1,000
4D-V	12,000	

LOWER BEAM

Test Points (degrees)	Candela Maximum	Candela Minimum
10U-90U	125	
4U-8L and 8R		64
2U-4L		135
1.5U-1R to 3R		200
1.5U-1R to R	1,400	
1U-1.5L to L	700	
0.5U-1.5L to L	1,000	
0.5U-1R to 3R	2,700	500
H-4L		135
H-8L		64
0.6D-1.3R		10,000
0.86D-V		4,500
0.86D-3.5L	12,000	1,800
1.5D-2R		15,000
2D-9L and 9R		1,250
2D-15L and 15R		1,000
4D-4R	12,500	
4D-20L and 20R		300

Note: D means down; H means horizontal; L means left; R means right; U means up; and V means vertical.

Figure 19: Visibility of Installed Lighting Devices
(Lens Area Measurement Method)

Item	Corner Points ¹ (degrees)
Front Turn Signal Lamp ²	(15U, -45H ⁵), (15U, +45H) (15D, -45H ⁵), (15D, +45H)
Rear Turn Signal Lamp	(15U, -45H ⁵), (15U, +45H) (15D, -45H ⁵), (15D, +45H)
Stop Lamp ³	(15U, -45H), (15U, +45H) (15D, -45H), (15D, +45H)
Parking Lamp	(15U, -45H), (15U, +45H) (15D, -45H), (15D, +45H)
Tail Lamp ⁴	(15U, -45H), (15U, +45H) (15D, -45H), (15D, +45H)

¹ In the horizontal (H) direction, a minus (-) sign indicates an inward direction (toward the vehicle's longitudinal centerline) and a plus (+) sign indicates an outward direction.

² Where more than one lamp or optical area is lighted at the front on each side of a multipurpose passenger vehicle, truck, trailer, or bus of 2,032 mm or more overall width, only one such lamp or area need comply.

³ If a multiple lamp arrangement is used for a motorcycle stop lamp, the inboard angles for each lamp shall be 10 degrees.

⁴ If a multiple lamp arrangement is used for a motorcycle tail lamp, the inboard angles for each lamp shall be 45 degrees

⁵ For the rear turn signal lamps mounted on a motorcycle, the inboard angle shall be 20 degrees.

Note: U means up; H means horizontal; and D means down.

Figure 20: Visibility of Installed Lighting Devices
(Luminous Intensity Measurement Method)

Item	Corner Points¹ (degrees)	Minimum Luminous Intensity (candela)
Front Turn Signal Lamp ²	(15U, -45H ⁵), (15U, +80H) (15D, -45H ⁵), (15D, +80H)	0.3
Rear Turn Signal Lamp	(15U, -45H ⁵), (15U, +80H) (15D, -45H ⁵), (15D, +80H)	0.3
Stop Lamp ³	(15U, -45H), (15U, +45H) (15D, -45H), (15D, +45H)	0.3
Front Parking Lamp	(15U, -45H), (15U, +80H) (15D, -45H), (15D, +80H)	0.05
Tail Lamp ⁴	(15U, -45H ²), (15U, +80H) (15D, -45H ²), (15D, +80H)	0.05

¹ In the horizontal (H) direction, a minus (-) sign indicates an inward direction (toward the vehicle's longitudinal centerline) and a plus (+) sign indicates an outward direction.

² - 80H° for motorcycles incorporating a single lamp.

³ If a multiple lamp arrangement is used for a motorcycle stop lamp, the inboard angles for each lamp shall be 10 degrees.

⁴ If a multiple lamp arrangement is used for a motorcycle tail lamp, the inboard angles for each lamp shall be 45 degrees

⁵ For the rear turn signal lamps mounted on a motorcycle, the inboard angle shall be 20 degrees.

Note: U means up; H means horizontal; and D means down.

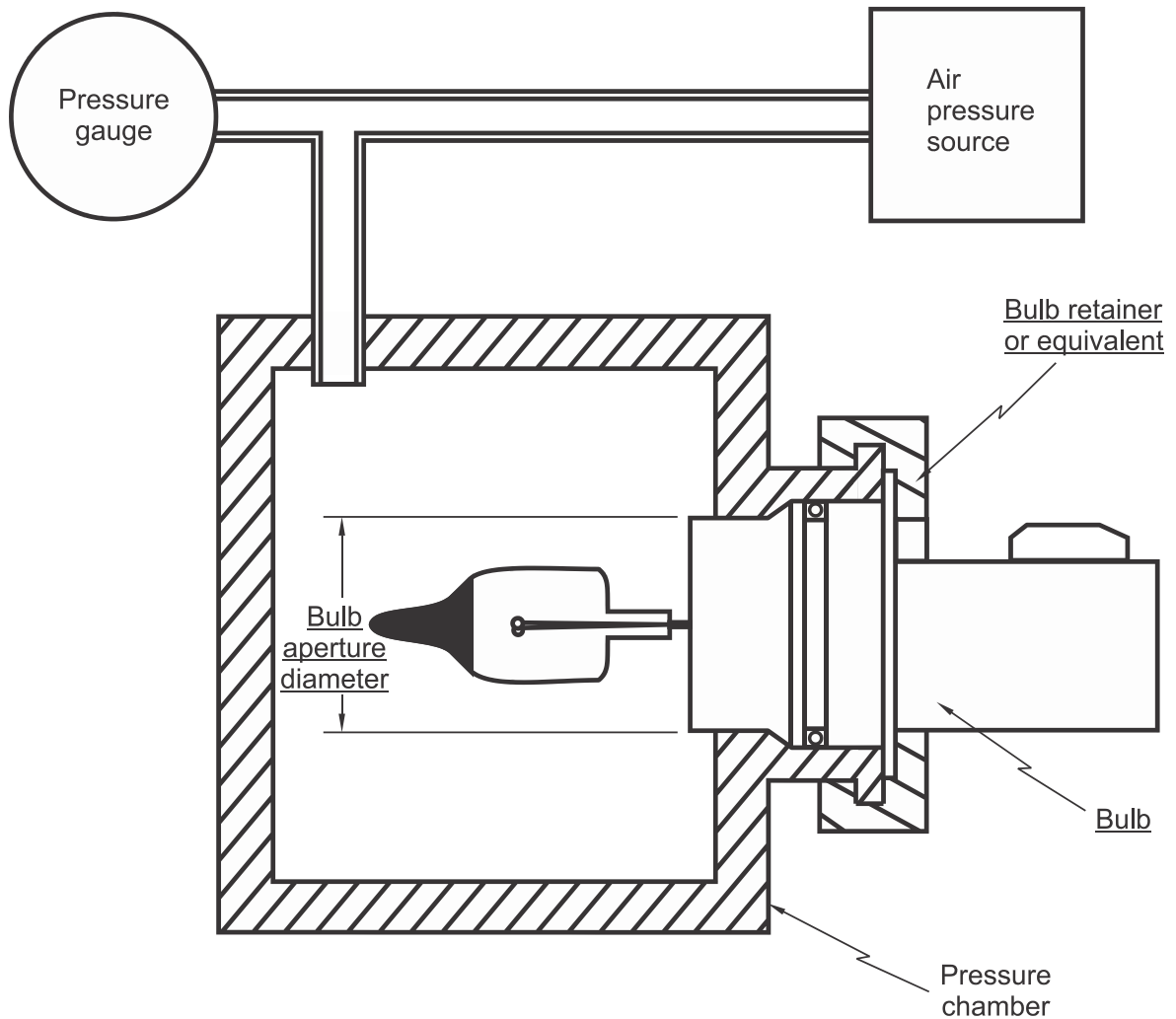

Aperture in pressure chamber for light source made to dimensions listed for aperture for light source in response to Part 564.5(a) accordance with subsection 108(5) of the MVSR.

Figure 25: Pressure Chamber

**Figure 26:
Table for Determining the Photometric Requirements of
Replaceable Bulb Headlamp Systems**

	Any dual filament type other than HB2 used alone or with another dual filament type other than HB2, filed in Docket No. NHTSA 98-3397	HB2 or any single filament type used alone or with any other single or dual filament type, filed in Docket No. NHTSA 98-3397
Four-Headlamp Systems	Fig. 27-1 or 27-2 Fig. 28-1 or 28-2 Fig. 15-1 or 15-2	Fig. 15-1 or 15-2
Two-Headlamp Systems	Fig. 27-1 or 27-2 Fig. 17-1 or 17-2	Fig. 17-1 or 17-2

Figure 27-1: Photometric Test Point Values for Mechanical Aim Headlighting Systems

Two-Lamp Systems

UPPER BEAM

Test Points (degrees)	Candela Maximum	Candela Minimum
2U-V		1,000
1U-3L and 3R		2,000
H-V	75,000	20,000
H-3L and 3R		10,000
H-6L and 6R		3,250
H-9L and 9R		1,500
H-12L and 12R		750
1.5D-V		5,000
1.5D-9L and 9R		1,500
2.5D-V		2,500
2.5D-12L and 12R		750
4D-V	5,000	

LOWER BEAM

Test Points (degrees)	Candela Maximum	Candela Minimum
10U-90U	125	
4U-8L and 8R		64
2U-4L		135
1.5U-1R to 3R		200
1.5U-1R to R	1,400	
1U-1.5L to L	700	
0.5U-1.5L to L	1,000	
0.5U-1R to 3R	2,700	500
H-4L		135
H-8L		64
0.5D-1.5L to L	2,500	
0.5D-1.5R	20,000	8,000
1D-6L		750
1.5D-2R		15,000
1.5D-9L and 9R		750
2D-15L and 15R		700
4D-4R	12,500	

Note: D means down; H means horizontal; L means left; R means right; U means up; and V means vertical.

Figure 27-2: Photometric Test Point Values for Visual/Optical Aim Headlighting Systems

Two-Lamp Systems

UPPER BEAM

Test Points (degrees)	Candela Maximum	Candela Minimum
2U-V		1,000
1U-3L and 3R		2,000
H-V	75,000	20,000
H-3L and 3R		10,000
H-6L and 6R		3,250
H-9L and 9R		1,500
H-12L and 12R		750
1.5D-V		5,000
1.5D-9L and 9R		1,500
2.5D-V		2,500
2.5D-12L and 12R		750
4D-V	5,000	

LOWER BEAM

Test Points (degrees)	Candela Maximum	Candela Minimum
10U-90U	125	
4U-8L and 8R		64
2U-4L		135
1.5U-1R to 3R		200
1.5U-1R to R	1,400	
1U-1.5L to L	700	
0.5U-1.5L to L	1,000	
0.5U-1R to 3R	2,700	500
H-4L		135
H-8L		64
0.6D-1.3R		10,000
0.86D-V		4,500
0.86D-3.5L	12,000	1,800
1.5D-2R		15,000
2D-9L and 9R		1,250
2D-15L and 15R		1,000
4D-4R	12,500	
4D-20L and 20R		300

Note: D means down; H means horizontal; L means left; R means right; U means up; and V means vertical.

**Figure 28-1: Photometric Test Point Values for
Mechanical Aim Headlighting Systems**

Four-Lamp Systems

UPPER BEAM

Headlamp Type	1A1, 1C1, and 1G1		2A1, 2C1, and 2G1	
	Candela Maximum	Candela Minimum	Candela Maximum	Candela Minimum
2U-V		750		750
1U-3L and 3R		3,000		2,000
H-V	60,000	18,000	15,000	7,000
H-3L and 3R		12,000		3,000
H-6L and 6R		3,000		2,000
H-9L and 9R		2,000		1,000
H-12L and 12R		750		750
1.5D-V		3,000		2,000
1.5D-9L and 9R		1,250		750
2.5D-V		1,500		1,000
2.5D-12L and 12R		600		400
4D-V	5,000		2,500	

LOWER BEAM

Headlamp Type	2A1, 2C1, and 2G1	
	Candela Maximum	Candela Minimum
10U-90U	125	
4U-8L and 8R		64
2U-4L		135
1.5U-1R to 3R		200
1.5U-1R to R	1,400	
1U-1.5L to L	700	
0.5U-1.5L to L	1,000	
0.5U-1R to 3R	2,700	500
H-4L		135
H-8L		64
0.5D-1.5L to L	2,500	
0.5D-1.5R	20,000	8,000
1D-6L		750
1.5D-2R		15,000
1.5D-9L and 9R		750
2D-15L and 15R		700
4D-4R	12,500	

Note: D means down; H means horizontal; L means left; R means right;
U means up; and V means vertical.

**Figure 28-2: Photometric Test Point Values for
Visual/Optical Aim Headlighting Systems**

Four-Lamp Systems

UPPER BEAM

Headlamp Type	1A1, 1C1, and 1G1		2A1, 2C1, and 2G1	
	Candela Maximum	Candela Minimum	Candela Maximum	Candela Minimum
2U-V		750		750
1U-3L and 3R		3,000		2,000
H-V	60,000	18,000	15,000	7,000
H-3L and 3R		12,000		3,000
H-6L and 6R		3,000		2,000
H-9L and 9R		2,000		1,000
H-12L and 12R		750		750
1.5D-V		3,000		2,000
1.5D-9L and 9R		1,250		750
2.5D-V		1,500		1,000
2.5D-12L and 12R		600		400
4D-V	5,000		2,500	

LOWER BEAM

Headlamp Type	2A1, 2C1, and 2G1	
	Candela Maximum	Candela Minimum
10U-90U	125	
4U-8L and 8R		64
2U-4L		135
1.5U-1R to 3R		200
1.5U-1R to R	1,400	
1U-1.5L to L	700	
0.5U-1.5L to L	1,000	
0.5U-1R to 3R	2,700	500
H-4L		135
H-8L		64
0.6D-1.3R		10,000
0.86D-V		4,500
0.86D-3.5L	12,000	1,800
1.5D-2R		15,000
2D-9L and 9R		1,250
2D-15L and 15R		1,000
4D-4R	12,500	
4D-20L and 20R		300

Note: D means down; H means horizontal; L means left; R means right;
U means up; and V means vertical.

**Figure 29: Minimum Photometric Performance of
Retroreflective Sheeting**

(Candela/Lux/Meter²)

Entrance Angle	Observation Angle				Grade
	0.2 Degree		0.5 Degree		
	White	Red	White	Red	
-4 degrees	250	60	65	15	DOT-C2
30 degrees	250	60	65	15	DOT-C2
45 degrees	60	15	15	4	DOT-C2
-4 degrees	165	40	43	10	DOT-C3
30 degrees	165	40	43	10	DOT-C3
45 degrees	40	10	10	3	DOT-C3
-4 degrees	125	30	33	9 8	DOT-C4
30 degrees	125	30	33	8	DOT-C4
45 degrees	30	8	8	2	DOT-C4

Note: D means down; H means horizontal; L means left; R means right; U means up; and V means vertical.

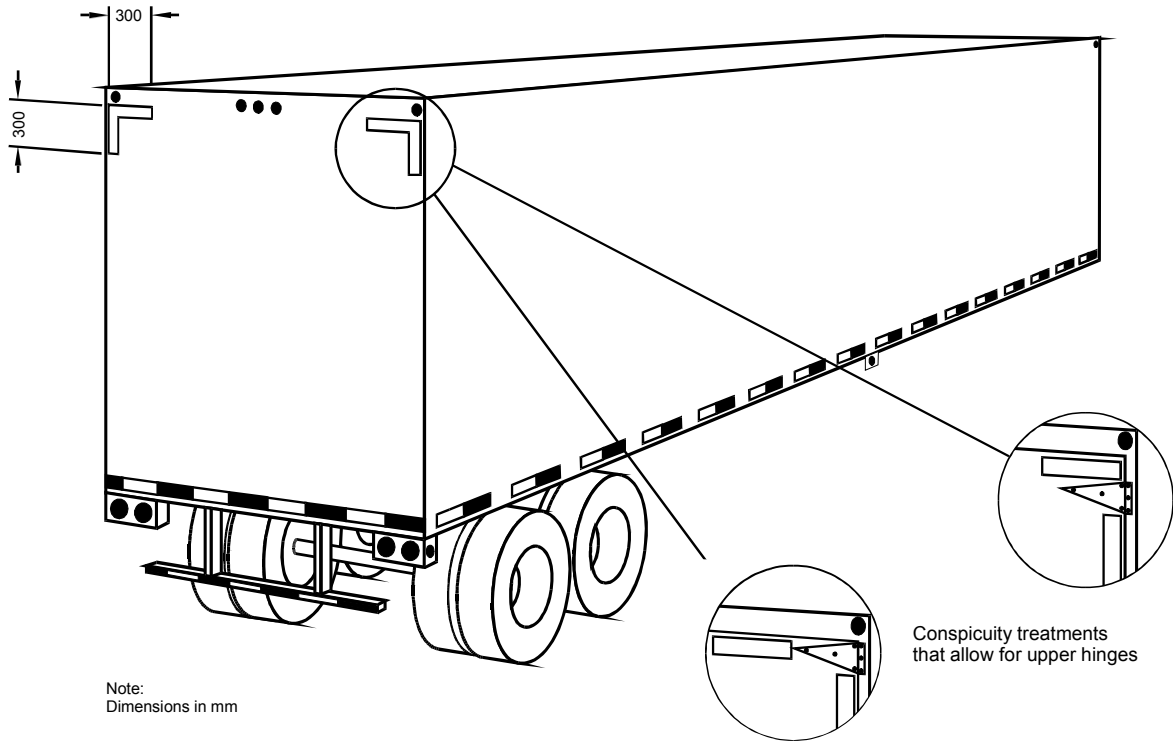
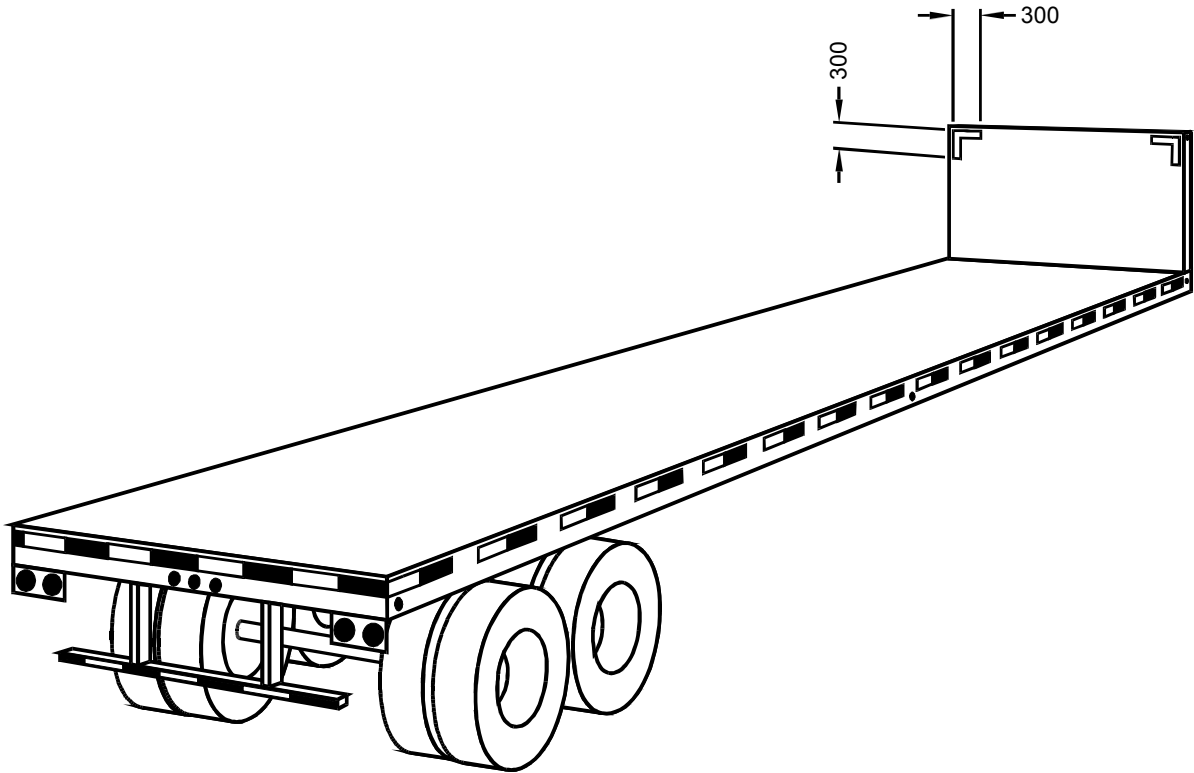

Figure 30-1: Trailer Conspicuity Treatment Example



Note:
Dimensions in mm

Figure 30-2: Trailer Conspicuity Treatment Example

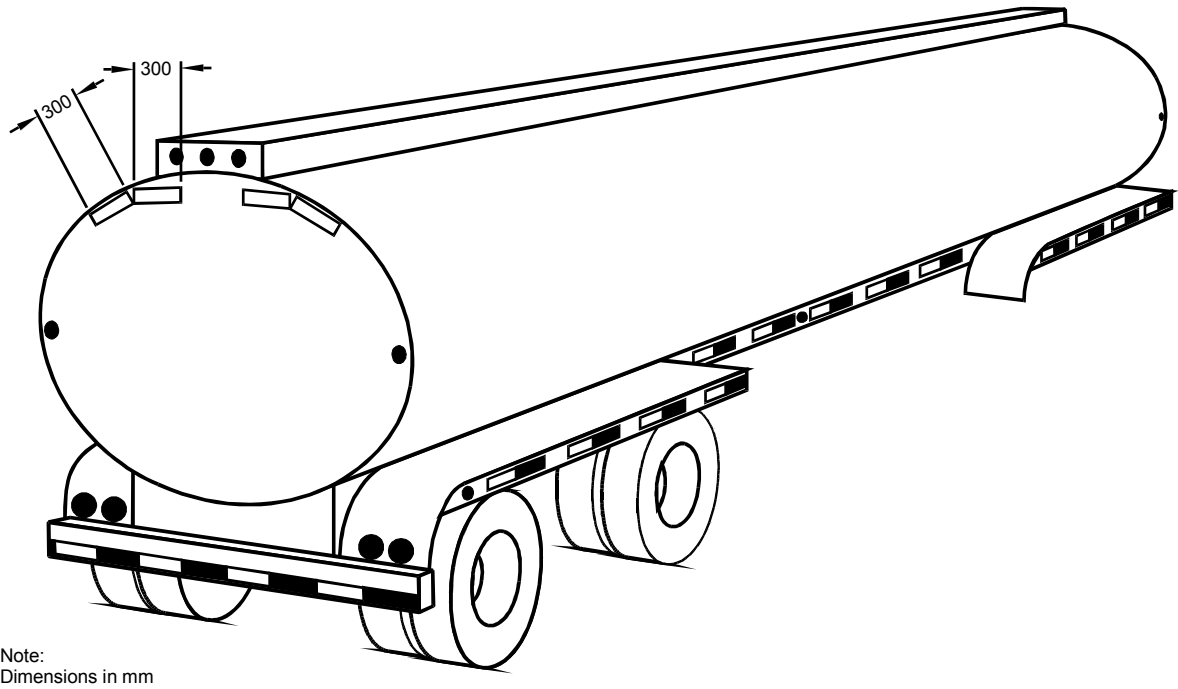

Figure 30-3: Trailer Conspicuity Treatment Example

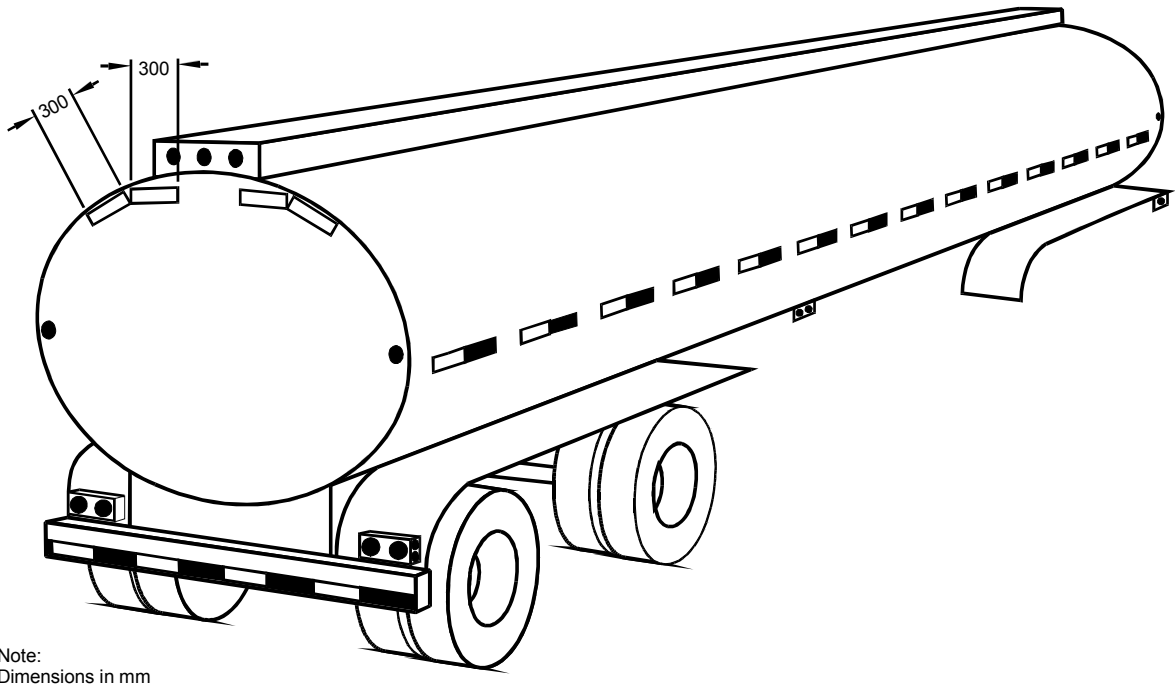

Figure 30-4: Trailer Conspicuity Treatment Example

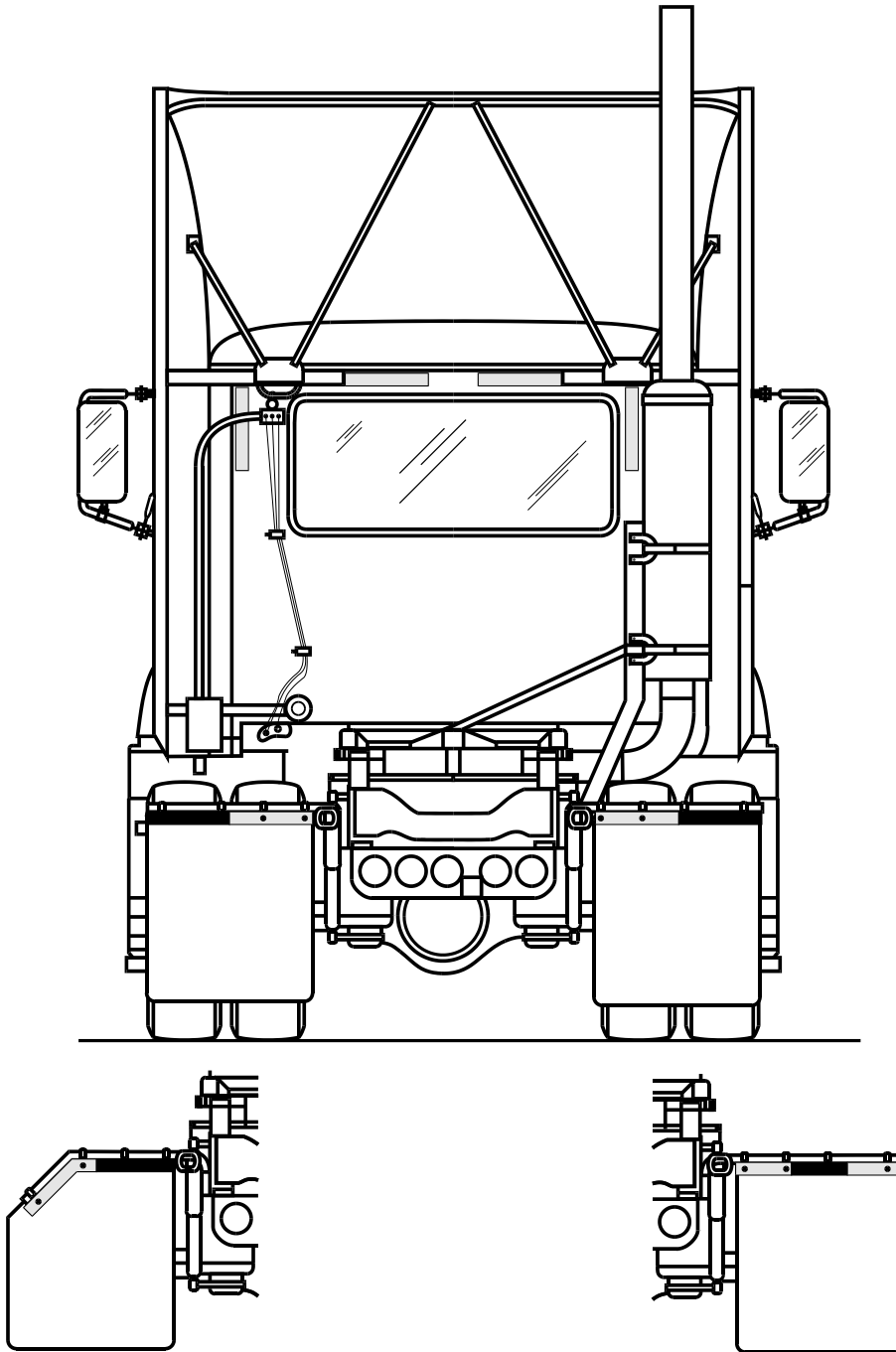

Figure 31: Tractor Conspicuity Treatment Example

Figure 32: Motorcycle and Limited-Speed Motorcycle ~~Motor-Driven Cycle~~ Headlamp Photometric Requirements

Test Points (degrees)		Motorcycle (candela)	<u>Limited-Speed Motorcycle</u> Motor-Driven Cycle (candela)	<u>Limited-Speed Motorcycle</u> Motor-Driven Cycle with Single Lamp System (candela)
Up or Down	Left or Right			
Lower Beam				
1.5U	1R to R	1400 max	1400 max	
1.5U	1R to 3R			1400 max
1U	1.5L to L	700 max	700 max	700 max
0.5U	1.5L to L	1000 max	1000 max	1000 max
0.5U	1R to 3R	2700 max	2700 max	2700 max
1.5D	9L and 9R	700 min		
2D	0.0R	7000 min	5000 min	4000 min
2D	3L and 3R	4000 min	3000 min	3000 min
2D	6L and 6R	1500 min	1500 min	1500 min
2D	12L and 12R	700 min		
3D	6L and 6R	800 min	800 min	
4D	0.0R	2000 min	2000 min	1000 min
4D	4R	12500 max	12500 max	12500 max
Upper Beam				
2U	0.0R	1000 min		
1U	3L and 3R	2000 min	2000 min	
0.0U	0.0R	12500 min	10000 min	
0.5D	0.0R	20000 min	20000 min	
0.5D	3L and 3R	10000 min	5000 min	
0.5D	6L and 6R	3300 min	2000 min	

0.5D	9L and 9R	1500 min		
0.5D	12L and 12R	800 min		
1D	0.0R	17500 min	15000 min	
2D	0.0R	5000 min	5000 min	
3D	0.0R	2500 min	2500 min	
3D	6L and 6R		800 min	
3D	9L and 9R	1500 min		
3D	12L and 12R	300 min		
4D	0.0R	1500 min		
4D	0.0R	7500 max	7500 max	
ANYWHERE	ANYWHERE	75000 max	75000 max	

Note: D means down; H means horizontal; L means left; R means right; U means up; and V means vertical.

**Table I: Required Motor Vehicle Lighting Equipment
other than Headlamps**

**Multipurpose Passenger Vehicles, Trucks, Trailers, and Buses
of 2.05 m or more (80 or more inches) Overall Width**

Item	Multipurpose passenger vehicles, trucks, and buses	Trailers	Applicable SAE standard or recommended practice (See S5 for subreferenced SAE materials)
Tail lamps	2 red	2 red	J585e, September 1977
Stop lamps	2 red	2 red	SAE J1398, May 1985
License plate lamp	1 white	1 white	J587 October 1981
Reflex reflectors	4 red; 2 amber	4 red; 2 amber	J594f, January 1977
Side marker lamps	2 red; 2 amber	2 red; 2 amber	J592e, July 1972
Backup lamp	1 white	None	J593c, February 1968
Turn signal lamps	2 red or amber; 2 amber	2 red or amber	SAE J1395, April 1985
Turn signal operating unit	1	None	J589, April 1964
Turn signal flasher	1	None	J590b, October 1965
Vehicular hazard warning signal operating unit	1	None	J910, January 1966
Vehicular hazard warning signal flasher	1	None	J945, February 1966
Identification lamps	3 amber; 3 red	3 red	J592e, July 1972
Clearance lamps	2 amber; 2 red	2 amber; 2 red	J592e, July 1972
Intermediate side marker lamps	2 amber	2 amber	J592e, July 1972
Intermediate side reflex reflectors	2 amber	2 amber	J594f, January 1977
Conspicuity	See S5.7	See S5.7	See S5.7

(14)

Table II: Location of Required Equipment

**Multipurpose Passenger Vehicles, Trucks, Trailers, and Buses
of 2.05 m or more (80 or more inches) Overall Width**

Item	Location on		Height above road surface measured from center of item on vehicle at curb weight <u>mass</u>
	Multipurpose passenger vehicles, trucks, and buses	Trailers	
Headlamps	On the front, each headlamp providing the upper beam, at the same height, 1 on each side of the vertical centerline, each headlamp providing the lower beam, at the same height, 1 on each side of the vertical centerline, as far apart as practicable. See also S7.	Not required	Not less than <u>559 mm</u> (22 inches), nor more than <u>1 372 mm</u> (54 inches)
Tail lamps	On the rear, 1 on each side of the vertical centerline, at the same height, and as far apart as practicable.	On the rear, 1 on each side of the vertical centerline, at the same height, and as far apart as practicable.	Not less than <u>380 mm</u> (15 inches), nor more than <u>1 830 mm</u> (72 inches)
Stop lamps	On the rear, 1 on each side of the vertical centerline, at the same height, and as far apart as practicable.	On the rear, 1 on each side of the vertical centerline, at the same height, and as far apart as practicable.	Not less than <u>380 mm</u> (15 inches), nor more than <u>1 830 mm</u> (72 inches)
License plate lamp	At rear license plate, to illuminate the plate from the top or sides.	At rear license plate, to illuminate the plate from the top or sides.	No requirement
Backup lamp	On the rear	Not required	No requirement
Turn signal lamps	At or near the front - 1 amber on each side of the vertical centerline, at the same height, and as far apart as practicable. On the rear - 1 red or amber on each side of the vertical centerline, at the same height, and as far apart as practicable.	On the rear - 1 red or amber on each side of the vertical centerline, at the same height, and as far apart as practicable.	Not less than <u>380 mm</u> (15 inches), nor more than <u>2 110 mm</u> (83 inches)
Identification lamps	On the front and rear - 3 lamps, amber in front, red in rear, as close as practicable to the top of the vehicle, at the same height, as close as practicable to the vertical centerline, with lamp centers spaced not less than <u>150 mm</u> (6 inches) or more than <u>300 mm</u> (12 inches) apart. Alternatively, the front lamps may be located as close as practicable to the top of the cab.	On the rear - 3 lamps as close as practicable to the top of the vehicle at the same height, as close as practicable to the vertical centerline, with lamp centers spaced not less than <u>150 mm</u> (6 inches) or more than <u>300 mm</u> (12 inches) apart.	No requirement

Clearance lamps	On the front and rear - 2 amber lamps on front, 2 red lamps on rear, to indicate the overall width of the vehicle, one on each side of the vertical centerline, at the same height, and as near the top as practicable.	On the front and rear - 2 amber lamps on front, 2 red lamps on rear, to indicate the overall width of the vehicle, one on each side of the vertical centerline, at the same height, and as near the top as practicable.	No requirement
Intermediate side marker lamps	On each side - 1 amber lamp located at or near the midpoint between the front and rear side marker lamps.	On each side - 1 amber lamp located at or near the midpoint between the front and rear side marker lamps.	Not less than <u>380 mm</u> (15 inches)

Table II (Cont'd): Location of Required Equipment

**Multipurpose Passenger Vehicles, Trucks, Trailers, and Buses
of 2.05 m or more (80 or more inches) Overall Width**

Item	Location on		Height above road surface measured from center of item on vehicle at curb weight <u>mass</u>
	Multipurpose passenger vehicles, trucks, and buses	Trailers	
Intermediate side reflex reflectors	On each side - 1 amber located at or near the midpoint between the front and rear side reflex reflectors.	On each side - 1 amber located at or near the midpoint between the front and rear side reflex reflectors.	Not less than <u>380 mm</u> (15 inches), nor more than <u>1 530 mm</u> (60 inches)
Conspicuity	See S5.7	See S5.7	See S5.7
Reflex reflectors	On the rear - 1 red on each side of the vertical centerline, as far apart as practicable, and at the same height. On each side - 1 red as far to the rear as practicable, and 1 amber as far to the front as practicable.	On the rear - 1 red on each side of the vertical centerline, as far apart as practicable, and at the same height. On each side - 1 red as far to the rear as practicable, and 1 amber as far to the front as practicable.	<u>Not less than 380 mm</u> (15 inches), <u>nor more than 1 530 mm</u> (60 inches)
Side marker lamps	On each side - 1 red as far to the rear as practicable, and 1 amber as far to the front as practicable.	On each side - 1 red as far to the rear as practicable, and 1 amber as far to the front as practicable.	Not less than <u>380 mm</u> (15 inches), and on the rear of trailers, not more than <u>1 530 mm</u> (60 inches)

Table III: Required Motor Vehicle Lighting Equipment

All Passenger Cars and Motorcycles, and Multipurpose Passenger Vehicles, Trucks, Buses and Trailers, of Less Than 2.05 m (80 inches) Overall Width

Item	Passenger cars, multipurpose passenger vehicles, trucks, and buses	Trailers	Motorcycles	Applicable SAE standard or recommended practice (See S5 for subreferenced SAE materials)
Headlamps	See S7	None	See S7.9	<u>For motorcycles only:</u> J566, January 1960
Tail lamps	2 red	2 red	1 red	J585e, September 1977
Stop lamps	2 red	2 red	1 red	SAE J586, February 1984
High-mounted stop lamp	1 red	Not required	Not required	J186a, September 1977
License plate lamp	1 white	1 white	1 white	J587, October 1981
Parking lamps	2 amber or white	None	None	J222, December 1970
Reflex reflectors	4 red; 2 amber	4 red; 2 amber	3 red; 2 amber	J594f, January 1977
Intermediate side reflex reflectors	2 amber	2 amber	None	J594f, January 1977
Intermediate side marker lamps	2 amber	2 amber	None	J592e, July 1972
Side marker lamps	2 red; 2 amber	2 red; 2 amber	None	J592e, July 1972
Backup lamp	1 white	None	None	J593c, February 1968
Turn signal lamps	2 red or amber; 2 amber	2 red or amber	2 amber; 2 red or amber	SAE J588, November 1984
Turn signal operating unit	1	None	1	J589, April 1964
Turn signal flasher	1	None	1	J590b, October 1965
Vehicular hazard warning signal operating unit	1	None	None	J910, January 1966
Vehicular hazard warning signal flasher	1	None	None	J945, February 1966

Table IV: Location of Required Equipment

**All Passenger Cars and Motorcycles, and Multipurpose Passenger Vehicles,
Trucks, Trailers, and Buses of Less Than 2.05 m (80 inches) Overall Width**

Item	Location on		Height above road surface measured from center of item on vehicle at curb weight <u>mass</u>
	Passenger cars, multipurpose passenger vehicles, trucks, trailers, and buses	Motorcycles	
Headlamps	On the front, each headlamp providing the <u>upper lower</u> beam, at the same height, 1 on each side of the vertical centerline, each headlamp providing the <u>lower upper</u> beam, at the same height, 1 on each side of the vertical centerline, as far apart as practicable. See also S7.	See S7.9	Not less than <u>559 mm</u> (22 inches), nor more than <u>1 372 mm</u> (54 inches)
Tail lamps	On the rear-1 on each side of the vertical centerline, at the same height, and as far apart as practicable.	On the rear-on the vertical centerline except that if two are used, they shall be symmetrically disposed about the vertical centerline.	Not less than <u>380 mm</u> (15 inches), nor more than <u>1 830 mm</u> (72 inches)
Stop lamps	On the rear-1 on each side of the vertical centerline, at the same height, and as far apart as practicable.	On the rear-on the vertical centerline except that if two are used, they shall be symmetrically disposed about the vertical centerline.	Not less than <u>380 mm</u> (15 inches), nor more than <u>1 830 mm</u> (72 inches)
High-mounted stop lamp	On the rear, on the vertical centerline (See S5.1.1.27, S5.3.1.8, and Table III).	Not required	See S5.3.1.8 for passenger cars. Not less than <u>860 mm</u> (34 inches) for multipurpose passenger vehicles, trucks, and buses
License plate lamp	At rear license plate, to illuminate the plate from the top or sides.	At rear license plate	No requirement
Parking lamps	On the front - 1 on each side of the vertical centerline, at the same height, and as far apart as practicable.	Not required	Not less than <u>380 mm</u> (15 inches), nor more than <u>1 830 mm</u> (72 inches)
Reflex reflectors	On the rear - 1 red on each side of the vertical centerline, at the same height, and as far apart as practicable. On each side - 1 red as far to the rear as practicable, and 1 amber as far to the front as practicable.	On the rear - 1 red on the vertical centerline except that, if two are used on the rear, they shall be symmetrically disposed about the vertical centerline. On each side - 1 red as far to the rear as practicable, and 1 amber as far to the front as practicable.	Not less than <u>380 mm</u> (15 inches), nor more than <u>1 530 mm</u> (60 inches)
Backup lamp	On the rear	Not required	No requirement

Table IV (Cont'd): Location of Required Equipment

**All Passenger Cars and Motorcycles, and Multipurpose Passenger Vehicles,
Trucks, Trailers, and Buses of Less Than 2.05 m (80 inches) Overall Width**

Item	Location on		Height above road surface measured from center of item on vehicle at curb weight <u>mass</u>
	Passenger cars, multipurpose passenger vehicles, trucks, trailers, and buses	Motorcycles	
Turn signal lamps	<p>At or near the front - 1 amber on each side of the vertical centerline, at the same height, and as far apart as practicable.</p> <p>On the rear - 1 red or amber on each side of the vertical centerline, at the same height, and as far apart as practicable.</p>	<p>At or near the front - 1 amber on each side of the vertical centerline at the same height, and having a minimum horizontal separation distance (centerline of lamps) of <u>400 mm</u> (16 inches). Minimum edge to edge separation distance between lamp and headlamp is <u>100 mm</u> (4 inches).</p> <p>At or near the rear - 1 red or amber on each side of the vertical centerline, at the same height and having a minimum horizontal separation distance (centerline to centerline of lamps) of <u>230 mm</u> (9 inches). Minimum edge to edge separation distance between lamp and tail or stop lamp is 100 mm (4 inches), when a single stop and tail lamp is installed on the vertical centerline and the turn signal lamps are red.</p>	Not less than <u>380 mm</u> (15 inches), nor more than <u>2 110 mm</u> (83 inches)
Side marker lamps	On each side - 1 red as far to the rear as practicable, and 1 amber as far to the front as practicable.	Not required	Not less than <u>380 mm</u> (15 inches)
Intermediate side marker lamps	On each side - 1 amber located at or near the midpoint between the front and rear side marker lamps.	Not required	Not less than <u>380 mm</u> (15 inches)
Intermediate side reflex reflectors	On each side - 1 amber located at or near the midpoint between the front and rear side reflex reflectors.	Not required	Not less than <u>380 mm</u> (15 inches) nor more than <u>1 530 mm</u> (60 inches)

[Notes (1), (2), and (3) have been deleted.]