



Transport  
Canada  
Motor Vehicle  
Safety

Transports  
Canada  
Sécurité des  
véhicules  
automobiles

## TECHNICAL STANDARDS DOCUMENT No. 122, Revision 3

### MOTORCYCLE BRAKE SYSTEMS

The text of this document is based on the U.S. *Code of Federal Regulations, Title 49, Part 571*, Federal Motor Vehicle Safety Standard No. 122, §571.122, Motorcycle Brake Systems, revised as of October 1, 2013.

**Publication Date:**

**June 3, 2015**

**Effective Date:**

**June 3, 2015**

**Mandatory Compliance Date:**

**September 1, 2016**

*(Ce document est aussi disponible en français)*

## Introduction

As defined by section 12 of the *Motor Vehicle Safety Act*, a Technical Standards Document (TSD) is a document that is published by the Minister, as provided for in the regulations, that adapts, or that reproduces in whole or in part in the official languages of Canada, an enactment of a foreign government or material produced by an international organization. The adaptations may include amendments to the content of the originating enactment or material. Furthermore, the [Motor Vehicle Safety Regulations \(MVSR\)](#) may contain provisions setting out that the provisions of the Regulations prevail over the provisions of the TSD in the case of inconsistency. Consequently, it is advisable to read a TSD in conjunction with the Act and its counterpart Regulation. As a guide, where the MVSR contains a provision that specifies additional requirements or removes requirements from the TSD, footnotes will refer the reader to that provision of the MVSR.

TSDs are amended from time to time to include amendments made to the originating enactment or material, with adaptations as required. When the TSD is amended, a Notice of Revision is published in the *Canada Gazette* Part I. All TSDs are assigned a revision number, with “Revision 0” designating the initial version.

## Identification of Changes

Adaptations may be made that include amendments to the content of the originating enactment or material. Such adaptations are marked as follows:

- Underlined text indicates text that is not part of the originating enactment or material and which therefore represents additional text in comparison to the originating text.
- Struck out text is text reproduced from the originating enactment or material that has been deleted from the TSD and thus it is not to be read as part of the TSD nor as part of the material incorporated by reference into the MVSR.
- “CONTENT NOT REPRODUCED” informs the reader that the text of the corresponding provision of the originating enactment or material has not been reproduced in the TSD.

## Publication, Effective and Mandatory Compliance Dates

The publication date is the date the TSD appears on the Transport Canada website.

The effective date of an initial TSD (revision 0) is the date of coming into force of the provision of the MVSR that incorporates it by reference (the incorporating provision).

Similarly, the effective date of a revised TSD (e.g. revision 1) that is accompanied by an amendment to the incorporating provision of the MVSR is the date of coming into force of the amended incorporating provision.

The effective date of a revised TSD (e.g. revision 2) that is not accompanied by an amendment to the incorporating provision of the MVSR is the date of publication of the TSD.

The mandatory compliance date is the date upon which compliance with the requirements of the TSD is required by law. If the effective date and mandatory compliance date are different,

a manufacturer may follow the requirements that were applicable before the effective date, or those of the TSD, until the mandatory compliance date.

## **Official Version of Technical Standards Documents**

The PDF version is a replica of the TSD as published by the Department and is to be used for the purposes of legal interpretation and application.

## Table of Contents

<b>Introduction</b> .....	<b>i</b>
<b>S1. Scope</b> .....	<b>1</b>
<b>S2. Purpose</b> .....	<b>1</b>
<b>S3. Application</b> .....	<b>1</b>
<b>S4. Definitions</b> .....	<b>1</b>
<b>S5. General Requirements</b> .....	<b>4</b>
S5.1 Brake system requirements.....	4
S5.2 Durability.....	6
S5.3 Measurement of dynamic performance .....	7
<b>S6. Test conditions, procedures and performance requirements</b> .....	<b>7</b>
S6.1 General.....	7
S6.2 Preparation.....	8
S6.3 Dry stop test—single brake control actuated.....	10
S6.4 Dry stop test—all service brake controls actuated .....	10
S6.5 High speed test.....	11
S6.6 Wet brake test .....	12
S6.7 Heat fade test .....	14
S6.8 Parking brake system test—for motorcycles with parking brakes .....	16
S6.9 ABS tests .....	17
S6.10 Partial failure test—for split service brake systems .....	20
S6.11 Power-assisted braking system failure test.....	21

## List of Tables

<b>Table 1: Test Sequence</b> .....	<b>23</b>
<b>Table 2: Performance Requirements, Dry Stop Test – Single Brake Control Actuated</b> .....	<b>23</b>
<b>Table 3: ABS Tests</b> .....	<b>24</b>
<b>Table 4: Performance Requirements, Power-Assisted Braking System Failure Test</b> .....	<b>24</b>

## List of Figures

<b>Figure 1: Hand control lever force application points and direction</b> .....	<b>24</b>
<b>Figure 2: Typical Plug Type Thermocouple Installation</b> .....	<b>25</b>
<b>Figure 3: Wet brake test</b> .....	<b>26</b>

## S1. Scope

This Technical Standards Document (TSD) standard specifies requirements for motorcycle service brake systems and, where applicable, associated parking brake systems.

## S2. Purpose

The purpose of the TSD standard is to insure safe motorcycle braking performance under normal and emergency riding conditions.

## S3. Application

[CONTENT NOT REPRODUCED] For applicability, see Schedule III and subsections 122(1) and (19) of Schedule IV to the [Motor Vehicle Safety Regulations](#).

## S4. Definitions

**Antilock brake system** or **ABS** means a system which senses wheel slip and automatically modulates the pressure producing the braking forces at the wheel(s) to limit the degree of wheel slip. (*Dispositif de frein antiblocage ou « ABS »*)

**Baseline test** means a stop or a series of stops carried out in order to confirm the performance of the brake prior to subjecting it to a further test such as the heating procedure or wet brake stop. (*Essai de référence*)

**Brake** means those parts of the brake system where the forces opposing the movement of the motorcycle are developed. (*Frein*)

**Brake system** means the combination of parts consisting of the control, the brake, and the components that provide the functional link between the control and the brake, but excluding the engine, whose function it is to progressively reduce the speed of a moving motorcycle, bring it to a halt, and keep it stationary when halted. (*Système de freinage*)

**Category 3-1 motorcycle** means a two-wheeled motorcycle with an engine cylinder capacity in the case of a thermic engine not exceeding 50 cubic centimeters (cm<sup>3</sup>) and whatever the means of propulsion a maximum design speed not exceeding 50 kilometers per hour (km/h). (*Motocyclette de catégorie 3-1*)

**Category 3-2 motorcycle** means a three-wheeled motorcycle of any wheel arrangement with an engine cylinder capacity in the case of a thermic engine not exceeding 50 cm<sup>3</sup> and whatever the means of propulsion a maximum design speed not exceeding 50 km/h. (*Motocyclette de catégorie 3-2*)

**Category 3-3 motorcycle** means a two-wheeled motorcycle with an engine cylinder capacity in the case of a thermic engine exceeding 50 cm<sup>3</sup> or whatever the means of propulsion a maximum design speed exceeding 50 km/h. (*Motocyclette de catégorie 3-3*)

**Category 3-4 motorcycle** means a motorcycle manufactured with three wheels asymmetrically arranged in relation to the longitudinal median plane with an engine cylinder

capacity in the case of a thermic engine exceeding 50 cm<sup>3</sup> or whatever the means of propulsion a maximum design speed exceeding 50 km/h. (This category definition is intended to include motorcycles with sidecars.) (*Motocyclette de catégorie 3-4*)

**Category 3-5 motorcycle** means a motorcycle manufactured with three wheels symmetrically arranged in relation to the longitudinal median plane with an engine cylinder capacity in the case of a thermic engine exceeding 50 cm<sup>3</sup> or whatever the means of propulsion a maximum design speed exceeding 50 km/h. (*Motocyclette de catégorie 3-5*)

**Combined brake system** or **CBS** means:

- (a) For motorcycle categories 3-1 and 3-3: a service brake system where at least two brakes on different wheels are actuated by the operation of a single control.
- (b) For motorcycle categories 3-2 and 3-5: a service brake system where the brakes on all wheels are actuated by the operation of a single control.
- (c) For motorcycle category 3-4: a service brake system where the brakes on at least the front and rear wheels are actuated by the operation of a single control. (If the rear wheel and the asymmetrical wheel are braked by the same brake system, this is regarded as the rear brake.) (*Système de freinage combine ou « SFC »*)

**Control** means the part actuated directly by the rider in order to supply and regulate the energy required for braking the motorcycle. (*Commande*)

**Driver mass** means the nominal mass of a driver that equals 75 kg (68 kg occupant mass plus 7kg of luggage mass). (*Masse du conducteur*)

**Engine disconnected** means when the engine is no longer internally connected to the driving wheel(s), i.e., the clutch is disengaged and/or the transmission is in neutral. (*Moteur débrayé*)

**Gross vehicle mass** means the maximum mass of the fully laden solo vehicle, based on its construction and design performances, as declared by the manufacturer. (*Masse brute du véhicule*)

**Initial brake temperature** means the temperature of the hottest brake before any brake application. (*Température initiale des freins*)

**Laden** means the gross vehicle mass. (*Chargé*)

**Lightly loaded** means mass in running order plus 15 kg for test equipment, or the laden condition, whichever is less. In the case of ABS tests on a low friction surface (paragraphs S6.9.4 to S6.9.7), the mass for test equipment is increased to 30 kg to account for outriggers. (*Légèrement chargé*)

**Mass in running order** means the sum of unladen vehicle mass and driver mass. (*Masse en état de marche*)

**Peak braking coefficient** or **PBC** means the measure of tire-to-road surface friction based on the maximum deceleration of a rolling tire. (*Coefficient maximal de freinage ou « CFMP »*)

**Power-assisted braking system** means a brake system in which the energy necessary to produce the braking force is supplied by the physical effort of the rider assisted by one or more energy supplying devices, for example vacuum assisted (with vacuum booster).

*(Système de freinage assisté)*

**Secondary brake system** means the second service brake system on a motorcycle equipped with a combined brake system. *(Système de frein secondaire)*

**Service brake system** means a brake system which is used for slowing the motorcycle when in motion. *(Système de frein de service)*

**Sidecar** means a one-wheeled vehicle that is attached to the side of a motorcycle. *(Sidecar)*

**Single brake system** means a brake system which acts on only one axle. *(Système de freinage individuel)*

**Split service brake system** or **SSBS** means a brake system that operates the brakes on all wheels, consisting of two or more subsystems actuated by a single control designed so that a single failure in any subsystem (such as a leakage type failure of a hydraulic subsystem) does not impair the operation of any other subsystem. *(Système de frein de service partagé ou « SFSP »)*

**Stopping distance** means the distance traveled by the motorcycle from the point the rider begins to actuate the brake control to the point at which the motorcycle reaches full stop. For tests where simultaneous actuation of two controls is specified, the distance traveled is taken from the point the first control is actuated. *(Distance d'arrêt)*

**Test speed** means the motorcycle speed measured the moment the rider begins to actuate the brake control. For tests where simultaneous actuation of two controls is specified, the motorcycle speed is taken from the moment the first control is actuated. *(Vitesse d'essai)*

**Unladen vehicle mass** means the nominal mass of a complete vehicle as determined by the following criteria:

- (a) Mass of the vehicle with bodywork and all factory fitted equipment, electrical and auxiliary equipment for normal operation of vehicle, including liquids, tools, fire extinguisher, standard spare parts, chocks and spare wheel, if fitted.
- (b) The fuel tanks filled to at least 90 percent of rated capacity and the other liquid containing systems (except those for used water) to 100 percent of the capacity specified by the manufacturer. *(Masse du véhicule déchargé)*

**V<sub>max</sub>** means either the speed attainable by accelerating at a maximum rate from a standing start for a distance of 1.6 km on a level surface, with the vehicle lightly loaded, or the speed measured in accordance with International Organization for Standardization (ISO) 7117:1995(E) (~~incorporated by reference; see § 571.5~~) (see the list at Chapter V, Title 49, part 571.5 of the *Code of Federal Regulations* for the full citation, hereafter referred to as 49 CFR Part 571.5). *(V<sub>max</sub>)*

**Wheel lock** means the condition that occurs when there is 100 percent wheel slip. *(Blocage de roue)*

## S5. General Requirements

### S5.1 Brake system requirements

Each motorcycle shall meet each of the test requirements specified for a motorcycle of its category and for those brake features on the motorcycle.

**S5.1.1 Service brake system control operation.** Each motorcycle shall have a configuration that enables a rider to actuate the service brake system control while seated in the normal driving position and with both hands on the steering control.

**S5.1.2 Secondary brake system control operation.** Each motorcycle shall have a configuration that enables a rider to actuate the secondary brake system control while seated in the normal driving position and with at least one hand on the steering control.

#### S5.1.3 Parking brake system

- (a) If a parking brake system is fitted, it shall hold the motorcycle stationary on the slope prescribed in S6.8.2. The parking brake system shall:
  - (1) have a control which is separate from the service brake system controls; and
  - (2) be held in the locked position by solely mechanical means.
- (b) Each motorcycle equipped with a parking brake shall have a configuration that enables a rider to be able to actuate the parking brake system while seated in the normal driving position.

**S5.1.4 Two-wheeled motorcycles of categories 3-1 and 3-3.** Each category 3-1 and 3-3 two-wheeled motorcycle shall be equipped with either two separate service brake systems, or a split service brake system, with at least one brake operating on the front wheel and at least one brake operating on the rear wheel.

**S5.1.5 Three-wheeled motorcycles of category 3-4.** Each category 3-4 motorcycle shall comply with the brake system requirements in S5.1.4. A brake on the asymmetric wheel (with respect to the longitudinal axis) is not required.

**S5.1.6 Three-wheeled motorcycles of category 3-2.** Each category 3-2 motorcycle shall be equipped with a parking brake system plus one of the following service brake systems:

- (a) Two separate service brake systems, except CBS, which, when applied together, operate the brakes on all wheels; or
- (b) A split service brake system; or
- (c) A CBS that operates the brake on all wheels and a secondary brake system which may be the parking brake system.



**S5.1.7 Three-wheeled motorcycles of categories 3-5.** Each category 3-5 motorcycle shall be equipped with:

- (a) A parking brake system; and
- (b) A foot actuated service brake system which operates the brakes on all wheels by way of either:
  - (1) A split service brake system; or
  - (2) A CBS and a secondary brake system, which may be the parking brake system.

**S5.1.8 Two separate service brake systems.** For motorcycles where two separate service brake systems are installed, the systems may share a common brake, if a failure in one system does not affect the performance of the other.

**S5.1.9 Hydraulic service brake system.** For motorcycles that use hydraulic fluid for brake force transmission, the master cylinder shall:

- (a) Have a sealed, covered, separate reservoir for each brake system; and
- (b) Have a minimum reservoir capacity equivalent to 1.5 times the total fluid displacement required to satisfy the new to fully worn lining condition with the worst case brake adjustment conditions; and
- (c) Have a reservoir where the fluid level is visible for checking without removal of the cover.
- ~~(d) Have a brake fluid warning statement that reads as follows, in letters at least 3/32 of an inch high: *Warning: Clean filler cap before removing. Use only \_\_\_\_\_ fluid from a sealed container* (inserting the recommended type of brake fluid as specified in accordance with 49 CFR 571.116, e.g., "DOT 3"). The lettering shall be:
  - (1) Permanently affixed, engraved, or embossed;
  - (2) Located so as to be visible by direct view, either on or within 4 inches of the brake fluid reservoir filler plug or cap; and
  - (3) Of a color that contrasts with its background, if it is not engraved or embossed.~~

**S5.1.10 Warning lamps.** All warning lamps shall be mounted in the rider's view.

**S5.1.10.1 Split service brake system warning lamps**

- (a) Each motorcycle that is equipped with a split service brake system shall be fitted with a red warning lamp, which shall be activated:
  - (1) When there is a hydraulic failure on the application of a force of  $\leq 90$  N on the control; or
  - (2) Without actuation of the brake control, when the brake fluid level in the master cylinder reservoir falls below the greater of:

- (i) That which is specified by the manufacturer; or
  - (ii) That which is less than or equal to half of the fluid reservoir capacity.
- (b) To permit function checking, the warning lamp shall be illuminated by the activation of the ignition switch and shall be extinguished when the check has been completed. The warning lamp shall remain on while a failure condition exists whenever the ignition switch is in the “on” position.
- ~~(c) Each indicator lamp shall have the legend “Brake Failure” on or adjacent to it in letters not less than 3/32 of an inch high that shall be legible to the driver in daylight when lighted.~~
- (c) The warning lamp shall display the symbol for a brake system malfunction set out in the Table to section 101 of Schedule IV of the *Motor Vehicle Safety Regulations* (C.R.C c. 1038).

#### **S5.1.10.2 Antilock brake system warning lamps**

- (a) Each motorcycle equipped with an ABS system shall be fitted with a yellow warning lamp. The lamp shall be activated whenever there is a malfunction that affects the generation or transmission of signals in the motorcycle's ABS system.
- (b) To permit function checking, the warning lamp shall be illuminated by the activation of the ignition switch and extinguished when the check has been completed. The warning lamp shall remain on while a failure condition exists whenever the ignition switch is in the “on” position.
- ~~(c) The indicator shall be labeled in letters at least 3/32 of an inch high with the words “Antilock” or “Anti-lock” or “ABS” in accordance with Table 1 of Standard No. 101 (49 CFR 571.101).~~
- (c) The warning lamp shall display the symbol for an antilock brake system malfunction in vehicles other than trailers set out in the Table to section 101 of Schedule IV of the *Motor Vehicle Safety Regulations* (C.R.C., c. 1038).

## **S5.2 Durability**

**S5.2.1 Compensation for wear.** Wear of the brakes shall be compensated for by means of a system of automatic or manual adjustment.

**S5.2.2 Notice of wear.** The friction material thickness shall either be visible without disassembly, or where the friction material is not visible, wear shall be assessed by means of a device designed for that purpose.

**S5.2.3 Testing.** During all the tests in this standard and on their completion, there shall be no friction material detachment and no leakage of brake fluid.

## S5.3 Measurement of dynamic performance

There are two ways in which brake system performance is measured. The particular method to be used is specified in the respective tests in S6.

### S5.3.1 Stopping distance

- (a) Based on the basic equations of motion:

$$S = 0.1 \cdot V + (X) \cdot V^2 ,$$

Where:

S = stopping distance in meters

V = initial vehicle speed in km/h

X = a variable based on the requirement for each test

- (b) To calculate the corrected stopping distance using the actual vehicle test speed, the following formula is used:

$$S_s = 0.1 \cdot V_s + (S_a - 0.1 \cdot V_a) \cdot V_s^2 / V_a^2 ,$$

Where:

S<sub>s</sub> = corrected stopping distance in meters

V<sub>s</sub> = specified vehicle test speed in km/h

S<sub>a</sub> = actual stopping distance in meters

V<sub>a</sub> = actual vehicle test speed in km/h

NOTE TO S5.3.1(b): This equation is only valid when the actual test speed (V<sub>a</sub>) is within ±5 km/h of the specified test speed (V<sub>s</sub>).

**S5.3.2 Continuous deceleration recording.** The other method used to measure performance is the continuous recording of the vehicle instantaneous deceleration from the moment a force is applied to the brake control until the end of the stop.

## S6. Test conditions, procedures and performance requirements

### S6.1 General

### S6.1.1 Test surfaces

**S6.1.1.1 High friction surface.** A high friction surface is used for all dynamic brake tests excluding the ABS tests where a low-friction surface is specified. The high-friction surface test area is a clean, dry and level surface, with a gradient of  $\leq 1$  percent. The high-friction surface has a peak braking coefficient (PBC) of 0.9.

**S6.1.1.2 Low-friction surface.** A low-friction surface is used for ABS tests where a low-friction surface is specified. The low-friction surface test area is a clean and level surface, which may be wet or dry, with a gradient of  $\leq 1$  percent. The low-friction surface has a PBC of  $\leq 0.45$ .

**S6.1.1.3 Measurement of PBC.** The PBC is measured using the American Society for Testing and Materials (ASTM) E1136-93 (Reapproved 2003) standard reference test tire, in accordance with ASTM Method E1337-90 (Reapproved 2008), at a speed of 64 km/h (both publications incorporated by reference; see § 571.5)(see 49 CFR Part 571.5).

**S6.1.1.4 Parking brake system tests.** The specified test slope has a clean and dry surface that does not deform under the weight of the motorcycle.

**S6.1.1.5 Test lane width.** For two-wheeled motorcycles (motorcycle categories 3-1 and 3-3) the test lane width is 2.5 meters. For three-wheeled motorcycles (motorcycle categories 3-2, 3-4 and 3-5) the test lane width is 2.5 meters plus the vehicle width.

**S6.1.2 Ambient temperature.** The ambient temperature is between 4 °C and 45 °C.

**S6.1.3 Wind speed.** The wind speed is not more than 5 meters per second (m/s).

**S6.1.4 Test speed tolerance.** The test speed tolerance is  $\pm 5$  km/h. In the event of the actual test speed deviating from the specified test speed (but within the  $\pm 5$  km/h tolerance), the actual stopping distance is corrected using the formula in S5.3.1(b).

**S6.1.5 Automatic transmission.** Motorcycles with automatic transmission shall meet all test requirements—whether they are for “engine connected” or “engine disconnected.” If an automatic transmission has a neutral position, the neutral position is selected for tests where “engine disconnected” is specified.

**S6.1.6 Vehicle position and wheel lock.** The vehicle is positioned in the center of the test lane for the beginning of each stop. Stops are made without the vehicle wheels passing outside the applicable test lane and without wheel lock.

**S6.1.7 Test sequence.** Test sequence is as specified in Table 1.

## S6.2 Preparation

**S6.2.1 Engine idle speed.** The engine idle speed is set to the manufacturer's specification.

**S6.2.2 Tire pressures.** The tires are inflated to the manufacturer's specification for the vehicle loading condition for the test.

**S6.2.3 Control application points and direction.** For a hand control lever, the input force (F) is applied on the control lever's forward surface perpendicular to the axis of the lever fulcrum and its outermost point on the plane along which the control lever rotates (see Figure 1). The input force is applied to a point located 50 millimeters (mm) from the outermost point of the control lever, measured along the axis between the central axis of the fulcrum of the lever and its outermost point. For a foot control pedal, the input force is applied to the center of, and at right angles to, the control pedal.

**S6.2.4 Brake temperature measurement.** The brake temperature is measured on the approximate center of the facing length and width of the most heavily loaded shoe or disc pad, one per brake, using a plug-type thermocouple that is embedded in the friction material, as shown in Figure 2.

**S6.2.5 Burnishing procedure.** The vehicle brakes are burnished prior to evaluating performance.

#### **S6.2.5.1 Vehicle condition**

- (a) Vehicle lightly loaded.
- (b) Engine disconnected.

#### **S6.2.5.2 Conditions and procedure**

- (a) *Initial brake temperature.* Initial brake temperature before each brake application is  $\leq 100$  °C.
- (b) *Test speed.*
  - (1) Initial speed: 50 km/h or 0.8  $V_{max}$ , whichever is lower.
  - (2) Final speed = 5 to 10 km/h.
- (c) *Brake application.* Each service brake system control actuated separately.
- (d) *Vehicle deceleration.*
  - (1) Single front brake system only:
    - (i) 3.0-3.5 meters per second squared ( $m/s^2$ ) for motorcycle categories 3-3 and 3-4
    - (ii) 1.5-2.0  $m/s^2$  for motorcycle categories 3-1 and 3-2
  - (2) Single rear brake system only: 1.5-2.0  $m/s^2$
  - (3) CBS or split service brake system, and category 3-5: 3.5-4.0  $m/s^2$
- (e) *Number of decelerations.* There shall be 100 decelerations per brake system.
- (f) For the first stop, accelerate the vehicle to the initial speed and then actuate the brake control under the conditions specified until the final speed is reached. Then reaccelerate to the initial speed and maintain that speed until the brake temperature falls to the specified initial value. When these conditions are met, reapply the brake as

specified. Repeat this procedure for the number of specified decelerations. After burnishing, adjust the brakes in accordance with the manufacturer's recommendations.

### **S6.3 Dry stop test—single brake control actuated**

#### **S6.3.1 Vehicle condition**

- (a) The test is applicable to all motorcycle categories.
- (b) Laden. For vehicles fitted with CBS and split service brake system, the vehicle is tested in the lightly loaded condition in addition to the laden condition.
- (c) Engine disconnected.

#### **S6.3.2 Test conditions and procedure**

- (a) *Initial brake temperature.* Initial brake temperature is  $\geq 55$  °C and  $\leq 100$  °C.
- (b) *Test speed.*
  - (1) Motorcycle categories 3-1 and 3-2: 40 km/h or 0.9  $V_{max}$ , whichever is lower.
  - (2) Motorcycle categories 3-3, 3-4 and 3-5: 60 km/h or 0.9  $V_{max}$ , whichever is lower.
- (c) *Brake application.* Each service brake system control actuated separately.
- (d) *Brake actuation force.*
  - (1) Hand control:  $\leq 200$  N.
  - (2) Foot control:
    - (i)  $\leq 350$  N for motorcycle categories 3-1, 3-2, 3-3 and ~~3-5~~ 3-4.
    - (ii)  $\leq 500$  N for motorcycle category ~~3-4~~ 3-5.
- (e) Number of stops: until the vehicle meets the performance requirements, with a maximum of 6 stops
- (f) For each stop, accelerate the vehicle to the test speed and then actuate the brake control under the conditions specified in this paragraph.

**S6.3.3 Performance requirements.** When the brakes are tested in accordance with the test procedure set out in paragraph S6.3.2., the stopping distance shall be as specified in column 2 of Table 2.

### **S6.4 Dry stop test—all service brake controls actuated**

#### **S6.4.1 Vehicle condition**

- (a) The test is applicable to motorcycle categories 3-3, 3-4 and 3-5.
- (b) Lightly loaded.

- (c) Engine disconnected.

#### **S6.4.2 Test conditions and procedure**

- (a) *Initial brake temperature.* Initial brake temperature is  $\geq 55$  °C and  $\leq 100$  °C.
- (b) *Test speed.* Test speed is 100 km/h or 0.9  $V_{max}$ , whichever is lower.
- (c) *Brake application.* Simultaneous actuation of both service brake system controls, if so equipped, or of the single service brake system control in the case of a service brake system that operates on all wheels.
- (d) *Brake actuation force.*
  - (1) Hand control:  $\leq 250$  N.
  - (2) Foot control:
    - (i)  $\leq 400$  N for motorcycle categories 3-3 and 3-4.
    - (ii)  $\leq 500$  N for motorcycle category 3-5.
- (e) Number of stops: until the vehicle meets the performance requirements, with a maximum of 6 stops.
- (f) For each stop, accelerate the vehicle to the test speed and then actuate the brake control under the conditions specified in this paragraph.

**S6.4.3 Performance requirements.** When the brakes are tested in accordance with the test procedure set out in paragraph S6.4.2., the stopping distance (S) shall be  $S \leq 0.0060 V^2$  (where V is the specified test speed in km/h and S is the required stopping distance in meters).

### **S6.5 High speed test**

#### **S6.5.1 Vehicle condition**

- (a) The test is applicable to motorcycle categories 3-3, 3-4 and 3-5.
- (b) Test is not required for vehicles with  $V_{max} \leq 125$  km/h.
- (c) Lightly loaded.
- (d) Engine connected (clutch engaged) with the transmission in the highest gear.

#### **S6.5.2 Test conditions and procedure**

- (a) *Initial brake temperature.* Initial brake temperature is  $\geq 55$  °C and  $\leq 100$  °C.
- (b) *Test speed.*
  - (1) Test speed is 0.8  $V_{max}$  for motorcycles with  $V_{max} > 125$  km/h and  $< 200$  km/h.

- (2) Test speed is 160 km/h for motorcycles with  $V_{\max} \geq 200$  km/h.
- (c) *Brake application.* Simultaneous actuation of both service brake system controls, if so equipped, or of the single service brake system control in the case of a service brake system that operates on all wheels.
- (d) *Brake actuation force.*
- (1) Hand control:  $\leq 200$  N.
- (2) Foot control:
- (i)  $\leq 350$  N for motorcycle categories 3-3 and 3-4.
- (ii)  $\leq 500$  N for motorcycle category 3-5.
- (e) Number of stops: until the vehicle meets the performance requirements, with a maximum of 6 stops.
- (f) For each stop, accelerate the vehicle to the test speed and then actuate the brake control(s) under the conditions specified in this paragraph.

**S6.5.3 Performance requirements.** When the brakes are tested in accordance with the test procedure set out in paragraph S6.5.2, the stopping distance (S) shall be  $\leq 0.1 V + 0.0067 V^2$  (where V is the specified test speed in km/h and S is the required stopping distance in meters).

## **S6.6 Wet brake test**

### **S6.6.1 General information**

- (a) The test is comprised of two parts that are carried out consecutively for each brake system:
- (1) A baseline test based on the dry stop test—single brake control actuated (S6.3).
- (2) A single wet brake stop using the same test parameters as in (1), but with the brake(s) being continuously sprayed with water while the test is conducted in order to measure the brakes' performance in wet conditions.
- (b) The test is not applicable to parking brake systems unless it is the secondary brake.
- (c) Drum brakes or fully enclosed disc brakes are excluded from this test unless ventilation or open inspection ports are present.
- (d) This test requires the vehicle to be fitted with instrumentation that gives a continuous recording of brake control force and vehicle deceleration.

### **S6.6.2 Vehicle condition**

- (a) The test is applicable to all motorcycle categories.
- (b) Laden. For vehicles fitted with CBS and split service brake system, the vehicle is tested in the lightly loaded condition in addition to the laden condition.



- (c) Engine disconnected.
- (d) Each brake is fitted with water spray equipment as shown in Figure 3.
  - (1) *Disc brakes—sketch of water spray equipment.* The disc brake water spray equipment is installed as follows:
    - (i) Water is sprayed onto each brake with a flow rate of 15 liters/hr. The water is equally distributed on each side of the rotor.
    - (ii) If the surface of the rotor has any shielding, the spray is applied 45° prior to the shield.
    - (iii) If it is not possible to locate the spray in the position shown on the sketch, or if the spray coincides with a brake ventilation hole or similar, the spray nozzle may be advanced by an additional 90° maximum from the edge of the pad, using the same radius.
  - (2) *Drum brakes with ventilation and open inspection ports.* The water spray equipment is installed as follows:
    - (i) Water is sprayed equally onto both sides of the drum brake assembly (on the stationary back plate and on the rotating drum) with a flow rate of 15 liters/hr.
    - (ii) The spray nozzles are positioned two thirds of the distance from the outer circumference of the rotating drum to the wheel hub center.
    - (iii) The nozzle position is >15° from the edge of any opening in the drum back plate.

### **S6.6.3 Baseline test—test conditions and procedure**

- (a) The test in paragraph S6.3 (dry stop test—single brake control actuated) is carried out for each brake system but with the brake control force that results in a vehicle deceleration of 2.5-3.0 m/s<sup>2</sup>, and the following is determined:
  - (1) The average brake control force measured when the vehicle is traveling between 80 percent and 10 percent of the specified test speed.
  - (2) The average vehicle deceleration in the period 0.5 to 1.0 seconds after the point of actuation of the brake control.
  - (3) The maximum vehicle deceleration during the complete stop but excluding the final 0.5 seconds.
- (b) Conduct 3 baseline stops and average the values obtained in (1), (2), and (3).

### **S6.6.4 Wet brake test—test conditions and procedure**

- (a) The vehicle is ridden at the test speed used in the baseline test set out in S6.6.3 with the water spray equipment operating on the brake(s) to be tested and with no application of the brake system.

- (b) After a distance of  $\geq 500$  m, apply the average brake control force determined in the baseline test for the brake system being tested.
- (c) Measure the average vehicle deceleration in the period 0.5 to 1.0 seconds after the point of actuation of the brake control.
- (d) Measure the maximum vehicle deceleration during the complete stop but excluding the final 0.5 seconds.

**S6.6.5 Performance requirements.** When the brakes are tested in accordance with the test procedure set out in paragraph S6.6.4, the wet brake deceleration performance shall be:

- (a) The value measured in paragraph S6.6.4(c) shall be  $\geq 60$  percent of the average deceleration values recorded in the baseline test in paragraph S6.6.3(a)(2), i.e., in the period 0.5 to 1.0 seconds after the point of actuation of the brake control; and
- (b) The value measured in S6.6.4(d) shall be  $\leq 120$  percent of the average deceleration values recorded in the baseline test S6.6.3(a)(3), i.e., during the complete stop but excluding the final 0.5 seconds.

## **S6.7 Heat fade test**

### **S6.7.1 General information**

- (a) The test comprises three parts that are carried out consecutively for each brake system:
  - (1) A baseline test using the dry stop test—single brake control actuated (S6.3).
  - (2) A heating procedure which consists of a series of repeated stops in order to heat the brake(s).
  - (3) A hot brake stop using the dry stop test—single brake control actuated (S6.3), to measure the brake's performance after the heating procedure.
- (b) The test is applicable to motorcycle categories 3-3, 3-4 and 3-5.
- (c) The test is not applicable to parking brake systems and secondary service brake systems.
- (d) All stops are carried out with the motorcycle laden.
- (e) The heating procedure requires the motorcycle to be fitted with instrumentation that gives a continuous recording of brake control force and vehicle deceleration.

### **S6.7.2 Baseline test**

#### **S6.7.2.1 Vehicle condition—baseline test. Engine disconnected.**

#### **S6.7.2.2 Test conditions and procedure—baseline test**

- (a) *Initial brake temperature.* Initial brake temperature is  $\geq 55$  °C and  $\leq 100$  °C.
- (b) *Test speed.* Test speed is 60 km/h or 0.9  $V_{max}$ , whichever is the lower.

- (c) *Brake application.* Each service brake system control is actuated separately.
- (d) *Brake actuation force.*
  - (1) Hand control:  $\leq 200$  N.
  - (2) Foot control:
    - (i)  $\leq 350$  N for motorcycle categories 3-3 and 3-4.
    - (ii)  $\leq 500$  N for motorcycle category 3-5.
- (e) Accelerate the vehicle to the test speed, actuate the brake control under the conditions specified and record the control force required to achieve the vehicle braking performance specified in the table to S6.3.3 (Table 2).

### **S6.7.3 Heating procedure**

#### **S6.7.3.1 Vehicle condition—heating procedure. Engine transmission:**

- (a) From the specified test speed to 50 per cent specified test speed: connected, with the highest appropriate gear selected such that the engine speed remains above the manufacturer's specified idle speed.
- (b) From 50 per cent specified test speed to standstill: disconnected.

#### **S6.7.3.2 Test conditions and procedure—heating procedure**

- (a) *Initial brake temperature.* Initial brake temperature is (prior to first stop only)  $\geq 55$  °C and  $\leq 100$  °C.
- (b) *Test speed.*
  - (1) Single brake system, front wheel braking only: 100 km/h or 0.7  $V_{max}$ , whichever is the lower.
  - (2) Single brake system, rear wheel braking only: 80 km/h or 0.7  $V_{max}$ , whichever is the lower.
  - (3) CBS or split service brake system: 100 km/h or 0.7  $V_{max}$ , whichever is the lower.
- (c) *Brake application.* Each service brake system control actuated separately.
- (d) *Brake actuation force.*
  - (1) For the first stop: The constant control force that achieves a vehicle deceleration rate of 3.0—3.5  $m/s^2$  while the vehicle is decelerating between 80 percent and 10 percent of the specified speed.
  - (2) For the remaining stops:
    - (i) The same constant brake control force as used for the first stop.
    - (ii) Number of stops: 10.

(iii) Interval between stops: 1000 m.

- (e) Carry out a stop to the conditions specified in this paragraph and then immediately use maximum acceleration to reach the specified speed and maintain that speed until the next stop is made.

**S6.7.4 Hot brake stop—test conditions and procedure.** Perform a single stop under the conditions used in the baseline test (S6.7.2) for the brake system that has been heated during the procedure in accordance with S6.7.3. This stop is carried out within one minute of the completion of the procedure set out in S6.7.3 with a brake control application force less than or equal to the force used during the test set out in S6.7.2.

**S6.7.5 Performance requirements.** When the brakes are tested in accordance with the test procedure set out in S6.7.4, the stopping distance  $S_2$  shall be  $\leq 1.67 S_1 - 0.67 \times 0.1V$ ,

Where:

$S_1$  = corrected stopping distance in meters achieved in the baseline test set out in S6.7.2.

$S_2$  = corrected stopping distance in meters achieved in the hot brake stop set out in S6.7.4.

$V$  = specified test speed in km/h.

## **S6.8 Parking brake system test—for motorcycles with parking brakes**

### **S6.8.1 Vehicle condition**

- (a) The test is applicable to motorcycle categories 3-2, 3-4 and 3-5.
- (b) Laden.
- (c) Engine disconnected.

### **S6.8.2 Test conditions and procedure**

- (a) *Initial brake temperature.* Initial brake temperature is  $\leq 100$  °C.
- (b) *Test surface gradient.* Test surface gradient is equal to 18 percent.
- (c) *Brake actuation force.*
  - (1) Hand control:  $\leq 400$  N.
  - (2) Foot control:  $\leq 500$  N.
- (d) For the first part of the test, park the vehicle on the test surface gradient facing up the slope by applying the parking brake system under the conditions specified in this paragraph. If the vehicle remains stationary, start the measurement of the test period.
- (e) The vehicle must remain stationary to the limits of traction of the braked wheels.

- (f) On completion of the test with vehicle facing up the gradient, repeat the same test procedure with the vehicle facing down the gradient.

**S6.8.3 Performance requirements.** When tested in accordance with the test procedure set out in S6.8.2, the parking brake system shall hold the vehicle stationary for 5 minutes when the vehicle is both facing up and facing down the gradient.

## **S6.9 ABS tests**

### **S6.9.1 General**

- (a) The tests are only applicable to the ABS fitted on motorcycle categories 3-1 and 3-3.
- (b) The tests are to confirm the performance of brake systems equipped with ABS and their performance in the event of ABS electrical failure.
- (c) *Fully cycling* means that the anti-lock system is repeatedly modulating the brake force to prevent the directly controlled wheels from locking.
- (d) Wheel-lock is allowed as long as the stability of the vehicle is not affected to the extent that it requires the operator to release the control or causes a vehicle wheel to pass outside the test lane.
- (e) The test series comprises the individual tests in Table 3, which may be carried out in any order.

### **S6.9.2 Vehicle condition**

- (a) Lightly loaded.
- (b) Engine disconnected.

### **S6.9.3 Stops on a high friction surface**

#### **S6.9.3.1 Test conditions and procedure**

- (a) *Initial brake temperature.* Initial brake temperature is  $\geq 55$  °C and  $\leq 100$  °C.
- (b) *Test speed.* Test speed is 60 km/h or 0.9 Vmax, whichever is lower.
- (c) *Brake application.* Simultaneous actuation of both service brake system controls, if so equipped, or of the single service brake control in the case of a service brake system that operates on all wheels.
- (d) *Brake actuation force.* The force applied is that which is necessary to ensure that the ABS will cycle fully throughout each stop, down to 10 km/h.
- (e) If one wheel is not equipped with ABS, the control for the service brake on that wheel is actuated with a force that is lower than the force that will cause the wheel to lock.
- (f) Number of stops: until the vehicle meets the performance requirements, with a maximum of 6 stops.

- (g) For each stop, accelerate the vehicle to the test speed and then actuate the brake control under the conditions specified in this paragraph.

**S6.9.3.2 Performance requirements.** When the brakes are tested in accordance with the test procedures referred to in S6.9.3.1:

- (a) The stopping distance (S) shall be  $\leq 0.0063 V^2$  (where V is the specified test speed in km/h and S is the required stopping distance in meters); and
- (b) there shall be no wheel lock beyond that allowed for in paragraph S6.9.1(d), and the vehicle wheels shall stay within the test lane.

#### **S6.9.4 Stops on a low friction surface**

**S6.9.4.1 Test conditions and procedure.** As set out in S6.9.3.1, but using the low friction surface instead of the high friction one.

**S6.9.4.2 Performance requirements.** When the brakes are tested in accordance with the test procedures set out in S6.9.4.1:

- (a) the stopping distance (S) shall be  $\leq 0.0056 V^2 / P$  (where V is the specified test speed in km/h, P is the peak braking coefficient and S is the required stopping distance in meters); and
- (b) there shall be no wheel lock beyond that allowed for in paragraph S6.9.1(d), and the vehicle wheels shall stay within the test lane.

#### **S6.9.5 Wheel lock checks on high and low friction surfaces**

##### **S6.9.5.1 Test conditions and procedure**

- (a) *Test surfaces.* High friction or low friction surface, as applicable.
- (b) *Initial brake temperature.* Initial brake temperature is  $\geq 55$  °C and  $\leq 100$  °C.
- (c) *Test speed.*
- (1) On the high friction surface: 80 km/h or 0.8 Vmax, whichever is lower.
  - (2) On the low friction surface: 60 km/h or 0.8 Vmax, whichever is lower.
- (d) *Brake application.*
- (1) Each service brake system control actuated separately.
  - (2) Where ABS is fitted to both brake systems, simultaneous actuation of both brake controls in addition to (1).
- (e) *Brake actuation force.* The force applied is that which is necessary to ensure that the ABS will cycle fully throughout each stop, down to 10 km/h.
- (f) *Brake application rate.* The brake control actuation force is applied in 0.2-0.5 seconds.

- (g) Number of stops: until the vehicle meets the performance requirements, with a maximum of 3 stops.
- (h) For each stop, accelerate the vehicle to the test speed and then actuate the brake control under the conditions specified in this paragraph.

**S6.9.5.2 Performance requirements.** When the brakes are tested in accordance with the test procedures set out in S6.9.5.1, there shall be no wheel lock beyond that allowed for in paragraph S6.9.1(d), and the vehicle wheels shall stay within the test lane.

### **S6.9.6 Wheel lock check—high to low friction surface transition**

#### **S6.9.6.1 Test conditions and procedure**

- (a) *Test surfaces.* A high friction surface immediately followed by a low friction surface.
- (b) *Initial brake temperature.* Initial brake temperature is  $\geq 55$  °C and  $\leq 100$  °C.
- (c) *Test speed.* The speed that will result in 50 km/h or 0.5  $V_{max}$ , whichever is the lower, at the point where the vehicle passes from the high friction to the low friction surface.
- (d) *Brake application.*
  - (1) Each service brake system control actuated separately.
  - (2) Where ABS is fitted to both brake systems, simultaneous actuation of both brake controls in addition to (1).
- (e) *Brake actuation force.* The force applied is that which is necessary to ensure that the ABS will cycle fully throughout each stop, down to 10 km/h.
- (f) Number of stops: until the vehicle meets the performance requirements, with a maximum of 3 stops.
- (g) For each stop, accelerate the vehicle to the test speed and then actuate the brake control before the vehicle reaches the transition from one friction surface to the other.

**S6.9.6.2 Performance requirements.** When the brakes are tested in accordance with the test procedures set out in S6.9.6.1, there shall be no wheel lock beyond that allowed for in paragraph S6.9.1(d), and the vehicle wheels shall stay within the test lane.

### **S6.9.7 Wheel lock check—low to high friction surface transition**

#### **S6.9.7.1 Test conditions and procedure**

- (a) *Test surfaces.* A low friction surface immediately followed by a high friction surface with a PBC  $\geq 0.8$ .
- (b) *Initial brake temperature.* Initial brake temperature is  $\geq 55$  °C and  $\leq 100$  °C.
- (c) *Test speed.* The speed that will result in 50 km/h or 0.5  $V_{max}$ , whichever is the lower, at the point where the vehicle passes from the low friction to the high friction surface.

(d) *Brake application.*

- (1) Each service brake system control applied separately.
  - (2) Where ABS is fitted to both brake systems, simultaneous application of both brake controls in addition to (1).
- (e) *Brake actuation force.* The force applied is that which is necessary to ensure that the ABS will cycle fully throughout each stop, down to 10 km/h.
- (f) Number of stops: until the vehicle meets the performance requirements, with a maximum of 3 stops.
- (g) For each stop, accelerate the vehicle to the test speed and then actuate the brake control before the vehicle reaches the transition from one friction surface to the other.
- (h) Record the vehicle's continuous deceleration.

**S6.9.7.2 Performance requirements.** When the brakes are tested in accordance with the test procedures set out in S6.9.7.1:

- (a) There shall be no wheel lock beyond that allowed for in paragraph S6.9.1(d), and the vehicle wheels shall stay within the test lane, and
- (b) within 1 second of the rear wheel passing the transition point between the low and high friction surfaces, the vehicle deceleration shall increase.

### **S6.9.8 Stops with an ABS electrical failure**

**S6.9.8.1 Test conditions and procedure.** With the ABS electrical system disabled, carry out the test set out in S6.3 (dry stop test—single brake control actuated) applying the conditions relevant to the brake system and vehicle being tested.

**S6.9.8.2 Performance requirements.** When the brakes are tested in accordance with the test procedure set out in S6.9.8.1:

- (a) The system shall comply with the failure warning requirements of S5.1.10.2; and
- (b) the minimum requirements for stopping distance shall be as specified in column 2 under the heading “Single brake system, rear wheel(s) braking only” in Table 2

## **S6.10 Partial failure test—for split service brake systems**

### **S6.10.1 General information**

- (a) The test is only applicable to vehicles that are equipped with split service brake systems.
- (b) The test is to confirm the performance of the remaining subsystem in the event of a hydraulic system leakage failure.



**S6.10.2 Vehicle condition**

- (a) The test is applicable to motorcycle categories 3-3, 3-4 and 3-5.
- (b) Lightly loaded.
- (c) Engine disconnected.

**S6.10.3 Test conditions and procedure**

- (a) *Initial brake temperature.* Initial brake temperature is  $\geq 55$  °C and  $\leq 100$  °C.
- (b) *Test speed.* Test speed is 50 km/h and 100 km/h or  $0.8 V_{\max}$ , whichever is lower.
- (c) Brake actuation force.
  - (1) Hand control:  $\leq 250$  N.
  - (2) Foot control:  $\leq 400$  N.
- (d) Number of stops: until the vehicle meets the performance requirements, with a maximum of 6 stops for each test speed.
- (e) Alter the service brake system to induce a complete loss of braking in any one subsystem. Then, for each stop, accelerate the vehicle to the test speed and then actuate the brake control under the conditions specified in this paragraph.
- (f) Repeat the test for each subsystem.

**S6.10.4 Performance requirements.** When the brakes are tested in accordance with the test procedure set out in S6.10.3:

- (a) the system shall comply with the failure warning requirements set out in paragraph S5.1.10.1; and
- (b) the stopping distance (S) shall be  $\leq 0.1 V + 0.0117 V^2$  (where V is the specified test speed in km/h and S is the required stopping distance in meters).

**S6.11 Power-assisted braking system failure test****S6.11.1 General information**

- (a) The test is not conducted when the vehicle is equipped with another separate service brake system.
- (b) The test is to confirm the performance of the service brake system in the event of failure of the power assistance.

**S6.11.2 Test conditions and procedure.** Carry out the test set out in S6.3.3 (dry stop test—single brake control actuated) for each service brake system with the power assistance disabled.

**S6.11.3 Performance requirements.** When the brakes are tested in accordance with the test procedure set out in S6.11.2, the stopping distance shall be as specified in column 2 of Table 4. Note that if the power assistance may be activated by more than one control, the above performance shall be achieved when each control is actuated separately.

**Table 1: Test Sequence**

Test order	Paragraph
1. Dry stop—single brake control actuated	S6.3
2. Dry stop—all service brake controls actuated	S6.4
3. High speed	S6.5
4. Wet brake	S6.6
5. If fitted:	
65.1. Parking brake system	S6.8
65.2. ABS	S6.9
65.3. Partial failure, for split service brake systems	S6.10
65.4. Power-assisted braking system failure	S6.11
6. Heat fade	S6.7

**Table 2: Performance Requirements, Dry Stop Test—Single Brake Control Actuated**

Column 1	Column 2
<b>Motorcycle category</b>	<b>Stopping Distance(s)</b> (where V is the specified test speed in km/h and S is the required stopping distance in meters)
<b>Single brake system, front wheel(s) braking only</b>	
3-1	$S \leq 0.1 V + 0.0111 V^2$ .
3-2	$S \leq 0.1 V + 0.0143 V^2$ .
3-3	$S \leq 0.1 V + 0.0087 V^2$ .
3-4	$S \leq 0.1 V + 0.0105 V^2$ .
3-5	Not applicable.
<b>Single brake system, rear wheel(s) braking only</b>	
3-1	$S \leq 0.1 V + 0.0143 V^2$ .
3-2	$S \leq 0.1 V + 0.0143 V^2$ .
3-3	$S \leq 0.1 V + 0.0133 V^2$ .
3-4	$S \leq 0.1 V + 0.0105 V^2$ .
3-5	Not applicable.
<b>Vehicles with CBS or split service brake systems: For laden and lightly loaded conditions</b>	
3-1 and 3-2	$S \leq 0.1 V + 0.0087 V^2$ .
3-3	$S \leq 0.1 V + 0.0076 V^2$ .
3-4	$S \leq 0.1 V + 0.0071 V^2$ .
3-5	$S \leq 0.1 V + 0.0077 V^2$ .
<b>Vehicles with CBS—secondary service brake system</b>	
ALL	$S \leq 0.1 V + 0.0154 V^2$ .

**Table 3: ABS Tests**

ABS Tests	Paragraph
a. Stops on a high friction surface—as specified in S6.1.1.1	S6.9.3
b. Stops on a low friction surface—as specified in S6.1.1.2	S6.9.4
c. Wheel lock checks on high and low friction surfaces	S6.9.5
d. Wheel lock check—high to low friction surface transition	S6.9.6
e. Wheel lock check—low to high friction surface transition	S6.9.7
f. Stops with an ABS electrical failure	S6.9.8

**Table 4: Performance Requirements, Power-Assisted Braking System Failure Test**

Column 1	Column 2
Vehicle category	Stopping Distance(s) (where V is the specified test speed in km/h and S is the required stopping distance in meters)
<b>Single brake system</b>	
3-1	$S \leq 0.1 V + 0.0143 V^2$ .
3-2	$S \leq 0.1 V + 0.0143 V^2$ .
3-3	$S \leq 0.1 V + 0.0133 V^2$ .
3-4	$S \leq 0.1 V + 0.0105 V^2$ .
<b>Vehicles with CBS or split service brake systems</b>	
All	$S \leq 0.1 V + 0.0154 V^2$ .

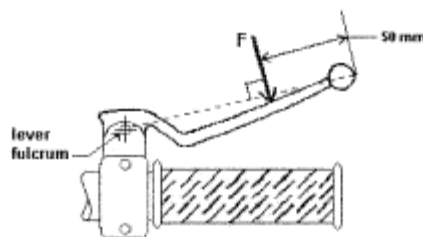

**Figure 1: Hand control lever force application points and direction**

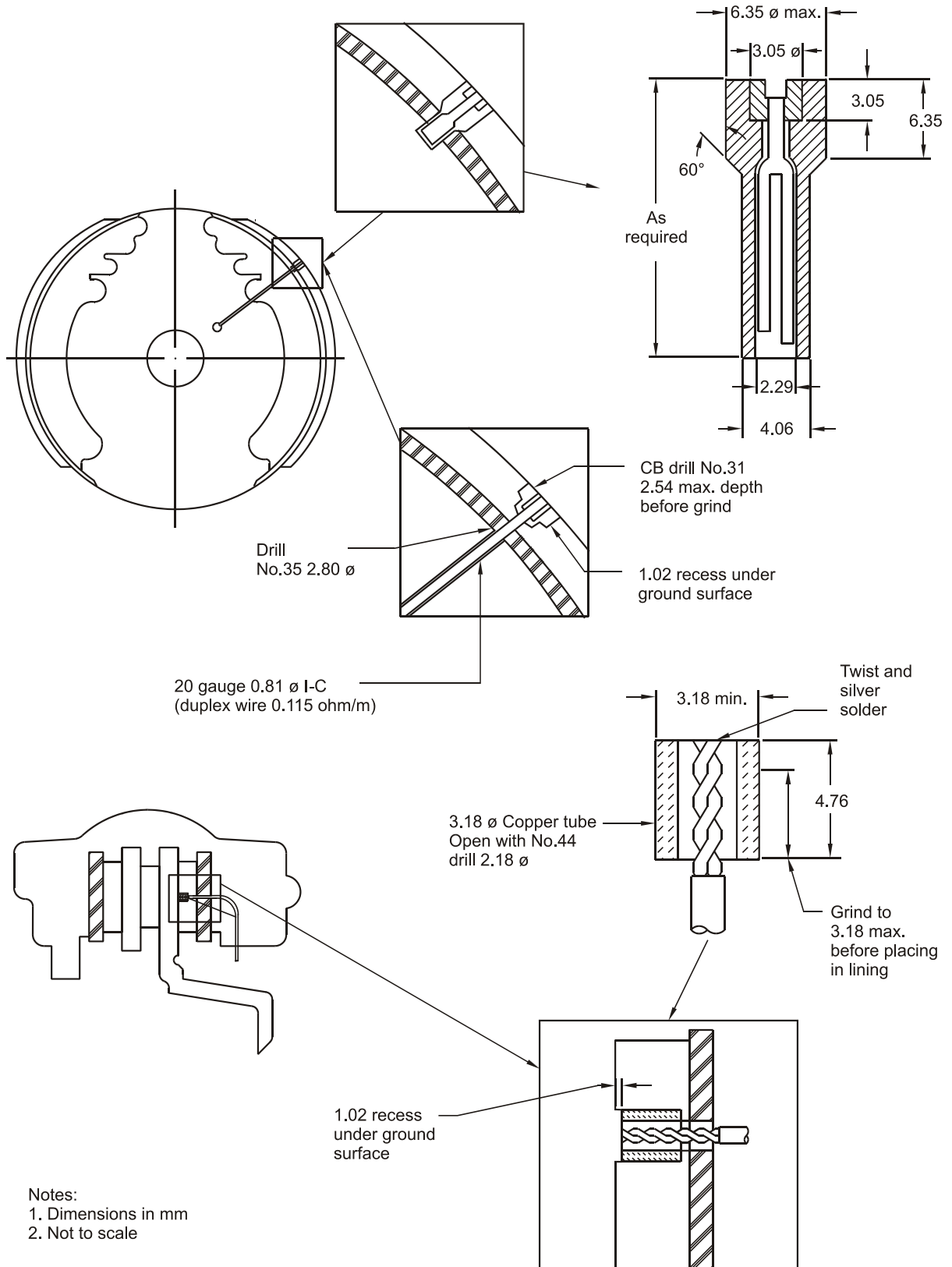

Notes:  
 1. Dimensions in mm  
 2. Not to scale

**Figure 2: Typical Plug Type Thermocouple Installation**

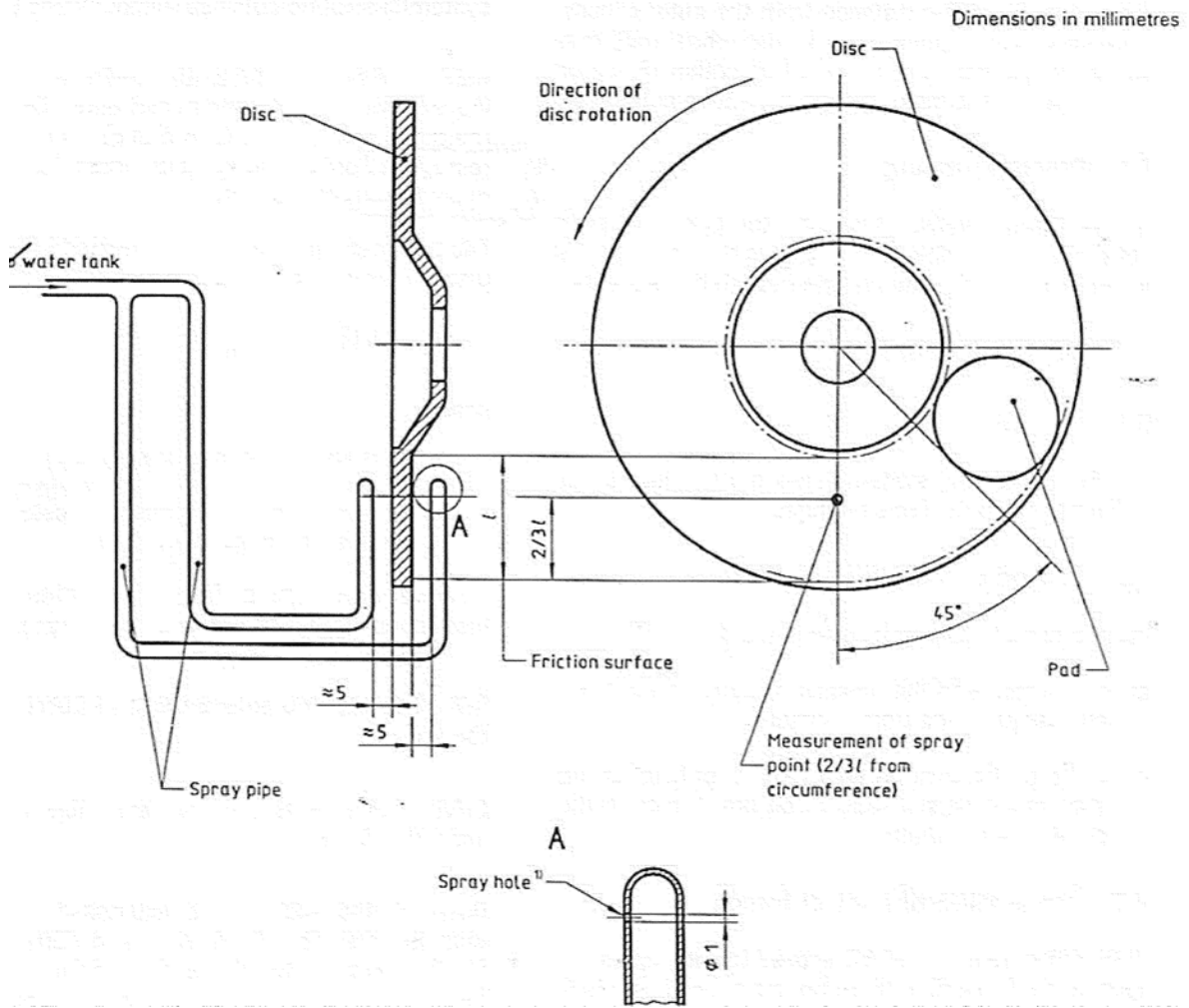

Figure 3: Wet brake test