



Transport
Canada
Motor Vehicle
Safety

Transports
Canada
Sécurité des
véhicules
automobiles

TECHNICAL STANDARDS DOCUMENT No. 208, Revision 0R

Occupant Crash Protection

The text of this document is based on *Federal Motor Vehicle Safety Standard No. 208, Occupant Crash Protection*, as published in the United States *Code of Federal Regulations*, Title 49, Part 571, revised as of October 1, 2012.

Publication Date:	February 13, 2013
Effective Date:	February 13, 2013
Mandatory Compliance Date:	August 13, 2013

(Ce document est aussi disponible en français)

Introduction

As defined by section 12 of the *Motor Vehicle Safety Act*, a Technical Standards Document (TSD) is a document that reproduces an enactment of a foreign government (e.g. a Federal Motor Vehicle Safety Standard issued by the U.S. National Highway Traffic Safety Administration). According to the Act, the [*Motor Vehicle Safety Regulations*](#) (MVSR) may alter or override some provisions contained in a TSD or specify additional requirements; consequently, it is advisable to read a TSD in conjunction with the Act and its counterpart Regulation. As a guide, where the corresponding Regulation contains additional requirements, footnotes indicate the amending subsection number.

TSDs are revised from time to time in order to incorporate amendments made to the reference document, at which time a Notice of Revision is published in the *Canada Gazette*, Part I. All TSDs are assigned a revision number, with “Revision 0” designating the original version.

Identification of Changes

In order to facilitate the incorporation of a TSD, certain non-technical changes may be made to the foreign enactment. These may include the deletion of words, phrases, figures, or sections that do not apply under the Act or Regulations, the conversion of imperial to metric units, the deletion of superseded dates, and minor changes of an editorial nature. Additions are underlined, and provisions that do not apply are ~~stroked through~~. Where an entire section has been deleted, it is replaced by: “[CONTENT NOT REPRODUCED]”. Changes are also made where there is a reporting requirement or reference in the foreign enactment that does not apply in Canada. For example, the name and address of the United States Department of Transportation are replaced by those of the Department of Transport.

Effective Date and Mandatory Compliance Date

The effective date of a TSD is the date of publication of its incorporating regulation or of the notice of revision in the *Canada Gazette*, and the date as of which voluntary compliance is permitted. The mandatory compliance date is the date upon which compliance with the requirements of the TSD is obligatory. If the effective date and mandatory compliance date are different, manufacturers may follow the requirements that were in force before the effective date, or those of the TSD, until the mandatory compliance date.

In the case of an initial TSD, or when a TSD is revised and incorporated by reference by an amendment to the Regulations, the mandatory compliance date is as specified in the Regulations, and it may be the same as the effective date. When a TSD is revised with no corresponding changes to the incorporating Regulations, the mandatory compliance date is six months after the effective date.

Official Version of Technical Standards Documents

The PDF version is a replica of the TSD as published by the Department and is to be used for the purposes of legal interpretation and application.

Table of Contents

Introduction.....	i
S1. Scope	1
S2. Purpose	1
S3. [CONTENT NOT REPRODUCED]	1
S4. General requirements.....	1
S5. Occupant crash protection requirements for the 50th percentile adult male dummy	6
S6. Injury criteria for the <u>Chapter V, Title 49, part 572 of the Code of Federal Regulations</u> , subpart E, Hybrid III test dummy	6
S7. Seat belt assembly requirements	8
S8. Test conditions	14
S9. [CONTENT NOT REPRODUCED]	16
S10. Test dummy positioning procedures	16
S11. [Reserved]	19
S12. [CONTENT NOT REPRODUCED]	19
S13. [CONTENT NOT REPRODUCED]	19
S14. Advanced air bag requirements for passenger cars and for trucks, buses, and multi-purpose passenger vehicles with a GVWR of 3,855 kg (8500 pounds) or less and an unloaded vehicle weight of 2,495 kg (5500 pounds) or less, except for walk-in van-type trucks or vehicles designed to be sold exclusively to the U.S. Postal Service.....	19
S15. Fixed collision Rigid barrier test requirements using 5th percentile adult female dummies	20
S16. Test procedures for rigid <u>fixed collision</u> barrier test requirements using 5th percentile adult female dummies	23
S17. Offset frontal deformable barrier requirements using 5th percentile adult test dummies	32
S18. Test procedure for offset frontal deformable barrier requirements using 5th percentile adult female dummies	32
S19. Requirements to provide protection for infants in rear facing and convertible child restraints and car beds	33
S20. Test procedure for S19	35

S21. Requirements using 3-year-old child dummies.....	43
S22. Test procedure for S21	45
S23. Requirements using 6-year-old child dummies.....	57
S24. Test procedure for S23	59
S25. Requirements using an out-of-position 5th percentile adult female dummy at the driver position	64
S26. Procedure for low risk deployment tests of driver air bag	66
S27. Option for dynamic automatic suppression system that suppresses the air bag when an occupant is out-of-position.....	69
S28. Test procedure for S27 of this standard. [Reserved].....	70
S29. Manufacturer option <u>for their vehicles to conform to certify</u> vehicles to certain static suppression test requirements using human beings rather than test dummies.	71

Table of Figures

Figure 1 (Reserved).....	72
Figure 2 (Content not reproduced)	72
Figure 3 Location of Anchoring Points for Latchplate Reach Limiting Chains or Strings to Test for Latchplate Accessibility Using Subpart E Test Device.....	72
Figure 4 Use of Clearance Test Block to Determine Hand/Arm Access	73
Figure 5 Webbing Tension Pull Device.....	74
Figure 6 Sled and Pulse Coordinates	75
Figure 6a. [CONTENT NOT REPRODUCED]	76
Figure 6b. [CONTENT NOT REPRODUCED].....	76
Figure 6c. [CONTENT NOT REPRODUCED]	76
Figure 7. [CONTENT NOT REPRODUCED].....	76
Figure 8. [CONTENT NOT REPRODUCED]	76
Figure 9. [CONTENT NOT REPRODUCED]	76
Figure 10. Configuration for Frontal Offset Deformable Barrier Test	76
Figure 11. [CONTENT NOT REPRODUCED].....	76
Figure 12. [CONTENT NOT REPRODUCED].....	76

Figure 13 5th Percentile Female Right Foot Support Block Appendix A to **TSD 208 §571.208**—Selection of Child Restraint Systems..... 77

Appendix A to TSD 208 §571.208—Selection of Child Restraint Systems..... 78

APPENDIX A-1 TO TSD 208 §571.208—SELECTION OF CHILD RESTRAINT SYSTEMS..... 79

S1. Scope

This Technical Standards Document (TSD) standard specifies performance requirements for the protection of vehicle occupants in crashes.

S2. Purpose

The purpose of this TSD standard is to reduce the number of deaths of vehicle occupants, and the severity of injuries, by specifying vehicle crashworthiness requirements in terms of forces and accelerations measured on anthropomorphic dummies in test crashes, and by specifying equipment requirements for active and passive restraint systems.

S3. [CONTENT NOT REPRODUCED]

S4. General requirements

S4.1 [CONTENT NOT REPRODUCED]

S4.2 [CONTENT NOT REPRODUCED]

S4.3 [CONTENT NOT REPRODUCED]

S4.4 [CONTENT NOT REPRODUCED]

S4.5 Other general requirements

S4.5.1 Labeling and owner's manual information

- (a) *Air bag maintenance or replacement information.* If the vehicle manufacturer recommends periodic maintenance or replacement of an air bag inflatable restraint system, as that term is defined in S4.1.5.1(b) of this standard, installed in a vehicle, that vehicle shall be labeled with the recommended schedule for maintenance or replacement. The schedule shall be specified by month and year, or in terms of vehicle distance travelled mileage, or by intervals measured from the date appearing on the vehicle compliance certification label provided pursuant to 49 CFR Part 567. The label shall be permanently affixed to the vehicle within the passenger occupant compartment and lettered in English in block capital and numerals not less than 2.4 mm (three thirty-seconds of an inch) high. ~~This label may be combined with the label required by S4.5.1(b) of this standard to appear on the sun visor.~~ If some regular maintenance or replacement of air bag the inflatable restraint system(s) in a vehicle is recommended by the vehicle manufacturer, the owner's manual shall also set forth the recommended schedule for maintenance or replacement.
- (b) [CONTENT NOT REPRODUCED]
- (c) [CONTENT NOT REPRODUCED]

(d) [CONTENT NOT REPRODUCED]

(e) [CONTENT NOT REPRODUCED]

(f) *Information to appear in owner's manual.*

- (1) The owner's manual for any vehicle equipped with an air bag inflatable restraint system shall include an accurate description of the vehicle's air bag system in an easily understandable format. The owner's manual shall include a statement to the effect that the vehicle is equipped with an air bag and lap/shoulder seat belt assembly at both front outboard designated seating positions, and that the air bag is a supplemental restraint at those designated seating positions. The information shall emphasize that all occupants, including the driver, should always wear their seat belts assemblies whether or not an air bag is also provided at their designated seating position to minimize the risk of severe injury or death in the event of a crash. The owner's manual shall also provide any necessary precautions regarding the proper positioning of occupants, including children, at designated seating positions equipped with air bags to ensure maximum safety protection for those occupants. The owner's manual shall also explain that no objects should be placed over or near the air bag on the instrument panel, because any such objects could cause harm if the vehicle is in a crash severe enough to cause the air bag to inflate.
- (2) For any vehicle conforming certified to meet the requirements specified in S14.5, S15, S17, S19, S21, S23, and S25, the manufacturer shall also include in the vehicle owner's manual a discussion of the advanced passenger air bag system installed in the vehicle. The discussion shall explain the proper functioning of the advanced air bag system and shall provide a summary of the actions that may affect the proper functioning of the system. The discussion shall include, at a minimum, accurate information on the following topics:
 - (i) A presentation and explanation of the main components of the advanced passenger air bag system.
 - (ii) An explanation of how the components function together as part of the advanced passenger air bag system.
 - (iii) The basic requirements for proper operation, including an explanation of the actions that may affect the proper functioning of the system.
 - (iv) For vehicles conforming certified to meet the requirements of S19.2, S21.2 or S23.2, a complete description of the passenger air bag suppression system installed in the vehicle, including a discussion of any suppression zone.
 - (v) An explanation of the interaction of the advanced passenger air bag system with other vehicle components, such as seat belts assemblies, seats or other components.
 - (vi) A summary of the expected outcomes when child restraint systems, children and small teenagers or adults are both properly and improperly positioned in

the passenger seat, including cautionary advice against improper placement of child restraint systems.

- (vii) For vehicles ~~conforming-certified to meet~~ the requirements of S19.2, S21.2 or S23.2, a discussion of the tell-tale light, specifying its location in the vehicle and explaining when the light is illuminated.
- (viii) Information on how to contact the vehicle manufacturer concerning modifications for disabled persons ~~with disabilities~~ that may affect the advanced air bag system.

(g) [CONTENT NOT REPRODUCED]

S4.5.2 *Readiness indicator.* An occupant protection system that deploys in the event of a crash shall have a monitoring system with a readiness indicator. The indicator shall monitor its own readiness and shall be clearly visible from the driver's designated seating position. If the vehicle is equipped with a single readiness indicator for both a driver and passenger air bag, and if the vehicle is equipped with an on-off switch permitted by S4.5.4 of this TSD ~~standard~~, the readiness indicator shall monitor the readiness of the driver air bag when the passenger air bag has been deactivated by means of the on-off switch, and shall not illuminate solely because the passenger air bag has been deactivated by the manual on-off switch. A list of the elements of the system being monitored by the indicator shall be included with the information furnished in accordance with S4.5.1 but need not be included on the label.

S4.5.3 [CONTENT NOT REPRODUCED]

S4.5.4 *Passenger air bag manual cut-off device.* Passenger cars, trucks, buses, and multi-purpose passenger vehicles manufactured before September 1, 2012 may be equipped with a device that deactivates the air bag installed at the right front outboard designated seating position in the vehicle, if all the conditions in S4.5.4.1 through S4.5.4.4 are satisfied.

S4.5.4.1 The vehicle complies with either S4.5.4.1(a) or S4.5.4.1(b).

- (a) The vehicle has no forward-facing designated seating positions to the rear of the front seating positions.
- (b) With the seats and seat backs adjusted as specified in S8.1.2 and S8.1.3, the distance, measured along a longitudinal horizontal line tangent to the highest point of the rear seat bottom in the longitudinal vertical plane described in either S4.5.4.1(b)(1) or S4.5.4.1(b)(2), between the rearward surface of the front seat back and the forward surface of the rear seat back is less than 720 millimeters.
 - (1) In a vehicle equipped with front bucket seats, the vertical plane at the centerline of the driver's seat cushion.
 - (2) In a vehicle equipped with front bench seating, the vertical plane which passes through the center of the steering wheel rim.

S4.5.4.2 The device is operable by means of the ignition key for the vehicle. The device shall be separate from the ignition switch for the vehicle, so that the driver must take some action with the ignition key other than inserting it or turning it in the ignition switch to deactivate the passenger air bag. Once deactivated, the passenger air bag shall remain deactivated until it is reactivated by means of the device.

S4.5.4.3 A tell-tale light in the interior of the vehicle shall be illuminated whenever the passenger air bag is turned off by means of the on-off switch. The tell-tale shall be clearly visible to occupants of all front seating positions. "Clearly visible" means within the normal range of vision throughout normal driving operations. ~~The telltale:~~

- ~~(a) Shall be yellow;~~
- ~~(b) Shall have the identifying words "PASSENGER AIR BAG OFF" or "PASS AIR BAG OFF" on the telltale or within 25 millimeters of the telltale;~~
- ~~(c) Shall remain illuminated for the entire time that the air bag is "off";~~
- ~~(d) Shall not be illuminated at any time when the air bag is "on"; and,~~
- ~~(e) Shall not be combined with the readiness indicator required by S4.5.2 of this standard.~~

S4.5.4.4 The vehicle owner's manual shall provide, in a readily understandable format:

- (a) Complete instructions on the operation of the on-off switch;
- (b) [CONTENT NOT REPRODUCED]
- (c) [CONTENT NOT REPRODUCED]

S4.5.5 [CONTENT NOT REPRODUCED]

S4.6 [CONTENT NOT REPRODUCED]

S4.7 [Reserved]

S4.8 [CONTENT NOT REPRODUCED]

S4.9 Values and tolerances

Wherever a range of values or tolerances are specified, requirements shall be met at all values within the range of values or tolerances. With respect to the positioning of anthropomorphic dummies, torso and spine angle tolerances shall be ± 2 degrees unless otherwise stated, and leg, thigh, foot, and arm angle tolerances shall be ± 5 degrees unless otherwise stated.

S4.10 Metric values

Specifications and requirements are given in metric units with ~~English~~ imperial units provided for reference. The metric values are controlling.

S4.11 Test duration for purpose of measuring injury criteria

- (a) For all barrier crashes, the injury criteria specified in this TSD standard shall be met when calculated based on data recorded for 300 milliseconds after the vehicle strikes the barrier.
- (b) For the 3-year-old and 6-year-old child dummy low risk deployment tests, the injury criteria specified in this TSD standard shall be met when calculated on data recorded for 100 milliseconds after the initial deployment of the air bag.
- (c) For 12-month-old infant dummy low risk deployment tests, the injury criteria specified in the TSD standard shall be met when calculated on data recorded for 125 milliseconds after the initiation of the final stage of air bag deployment designed to deploy in any full frontal fixed collision rigid barrier crash up to 64 km/h (40 mph).
- (d) For driver-side low risk deployment tests, the injury criteria shall be met when calculated based on data recorded for 125 milliseconds after the initiation of the final stage of air bag deployment designed to deploy in any full frontal fixed collision rigid barrier crash up to 26 km/h (16 mph).
- (e) The requirements for dummy containment shall continue until both the vehicle and the dummies have ceased moving.

S4.12 Suppression systems that do not detect dummies

For vehicles with occupant sensing systems that recognize humans and not dummies, such that the air bag or bags would not function in crash tests, the manufacturer shall provide Transport Canada NHTSA with information and equipment necessary to circumvent the suppression system for the crash test such that the restraint system operates as if 5th percentile adult female humans and 50th percentile adult male humans are seated in the vehicle.

S4.13 Data channels

For vehicles manufactured on or after September 1, 2001, all data channels used in injury criteria calculations shall be filtered using a phaseless digital filter, such as the Butterworth four-pole phaseless digital filter specified in appendix C of SAE Recommended Practice J211/1 MAR95 (~~incorporated by reference~~, see the list at Chapter V, Title 49, part 571.5 paragraph (k) of the Code of Federal Regulations for the full citation, hereafter Chapter V, Title 49, part 571.5 of the Code of Federal Regulations referred to as 49 CFR Part §571.5).

S5. Occupant crash protection requirements for the 50th percentile adult male dummy

S5.1 Frontal fixed collision barrier crash test

S5.1.1 *Belted test.*

(a) [CONTENT NOT REPRODUCED]

(b) *Vehicles conforming certified to S14 —*

(1) [CONTENT NOT REPRODUCED]

(2) *Vehicles that conform certified to ~~S14.3 or~~ S14.4.* Impact a vehicle traveling longitudinally forward at any speed, up to and including 56 km/h (35 mph), into a fixed collision rigid barrier that is perpendicular to the line of travel of the vehicle under the applicable conditions of S8 and S10. The test dummy specified in S8.1.8 placed in each front outboard designated seating position shall meet the injury criteria of S6.1, S6.2(b), ~~S6.3~~, S6.4(b), S6.5, and S6.6 of this TSD standard.

S5.1.2-[CONTENT NOT REPRODUCED]

S5.2 [CONTENT NOT REPRODUCED]

S5.3 [CONTENT NOT REPRODUCED]

S6. Injury criteria for the Chapter V, Title 49, part 572 of the Code of Federal Regulations, subpart E, Hybrid III test dummy

S6.1 All portions of the test dummy shall be contained within the outer surfaces of the vehicle ~~passenger~~ occupant compartment.

S6.2 Head injury criteria

(a) [CONTENT NOT REPRODUCED]

(b) (1) For any two points in time, t_1 and t_2 , during the event which are separated by not more than a 15 millisecond time interval and where t_1 is less than t_2 , the head injury criterion (HIC_{15}) shall be determined using the resultant head acceleration at the center of gravity of the dummy head, a_r , expressed as a multiple of g (the acceleration of gravity) and shall be calculated using the expression:

$$\left[\frac{1}{(t_2 - t_1)} \int_{t_1}^{t_2} a_r dt \right]^{2.5} (t_2 - t_1)$$

(2) The maximum calculated HIC_{15} value shall not exceed 700.

S6.3 [CONTENT NOT REPRODUCED]

S6.4 Chest deflection

(a) [CONTENT NOT REPRODUCED]

(b) Compressive deflection of the sternum relative to the spine shall not exceed 63 mm (2.5 in).¹

S6.5 The force transmitted axially through each upper leg shall not exceed 10 008.5 N (2250 pounds).

S6.6 Neck injury

When measuring neck injury, each of the following injury criteria shall be met.

(a) *Nij*.

- (1) The shear force (F_x), axial force (F_z), and bending moment (M_y) shall be measured by the dummy upper neck load cell for the duration of the crash event as specified in S4.11. Shear force, axial force, and bending moment shall be filtered for N_{ij} purposes at SAE Recommended Practice J211/1 MAR95 (~~incorporated by reference~~, see the list at 49 CFR Part §571.5 paragraph (k) for the full citation) Channel Frequency Class 600.
- (2) During the event, the axial force (F_z) can be either in tension or compression while the occipital condyle bending moment (M_{ocy}) can be in either flexion or extension. This results in four possible loading conditions for N_{ij} : tension-extension (N_{te}), tension-flexion (N_{tf}), compression-extension (N_{ce}), or compression-flexion (N_{cf}).
- (3) When calculating N_{ij} using equation S6.6(a)(4), the critical values, F_{zc} and M_{yc} , are:
 - (i) $F_{zc} = 6806 \text{ N}$ (1530 lbf) when F_z is in tension
 - (ii) $F_{zc} = 6160 \text{ N}$ (1385 lbf) when F_z is in compression
 - (iii) $M_{yc} = 310 \text{ Nm}$ (229 lbf-ft) when a flexion moment exists at the occipital condyle
 - (iv) $M_{yc} = 135 \text{ Nm}$ (100 lbf-ft) when an extension moment exists at the occipital condyle.

¹ Please see subsection 208(20) of Schedule IV of the MVSR, which modifies the requirement

- (4) At each point in time, only one of the four loading conditions occurs and the N_{ij} value corresponding to that loading condition is computed and the three remaining loading modes shall be considered a value of zero. The expression for calculating each N_{ij} loading condition is given by:

$$N_{ij} = (F_z/F_{zc}) + (M_{ocy}/M_{yc})$$

- (5) None of the four N_{ij} values shall exceed 1.0 at any time during the event.
- (b) *Peak tension.* Tension force (F_z), measured at the upper neck load cell, shall not exceed 4170 N (937 lbf) at any time.
- (c) *Peak compression.* Compression force (F_z), measured at the upper neck load cell, shall not exceed 4000 N (899 lbf) at any time.

S6.7 Unless otherwise indicated, instrumentation for data acquisition, data channel frequency class, and moment calculations are the same as given for the Chapter V, Title 49, part 572 of the Code of Federal Regulations, hereafter referred to as 49 CFR Part 572, Subpart E Hybrid III test dummy.

S7. Seat belt assembly requirements

~~As used in this section, a law enforcement vehicle means any vehicle manufactured primarily for use by the United States or by a State or local government for police or other law enforcement purposes.~~

S7.1 Adjustment

S7.1.1 [CONTENT NOT REPRODUCED]

S7.1.1.1 [CONTENT NOT REPRODUCED]

S7.1.1.2 [CONTENT NOT REPRODUCED]

S7.1.1.3 [CONTENT NOT REPRODUCED]

S7.1.1.4 [CONTENT NOT REPRODUCED]

S7.1.1.5 Passenger cars, and trucks, buses, and multi-purpose passenger vehicles with a GVWR of 4 536 kg (10,000 pounds) or less manufactured on or after September 1, 1995 shall meet the requirements of S7.1.1.5(a), S7.1.1.5(b) and S7.1.1.5(c).

- (a) Each designated seating position, except the driver's designated position, and except any right front designated seating position that is equipped with an automatic belt, that is in any motor vehicle, ~~except walk-in vans van-type vehicles and vehicles manufactured to be sold exclusively to the U.S. Postal Service,~~ and that is forward-facing or can be adjusted to be forward-facing, shall have a seat belt assembly whose lap belt pelvic restraint portion is lockable so that the seat belt assembly can be used

- to tightly secure a child restraint system. The means provided to lock the ~~lap belt or lap belt pelvic restraint~~ portion of the seat belt assembly shall not consist of any device that must be attached by the vehicle user to the seat belt assembly webbing, retractor, or any other part of the vehicle. Additionally, the means provided to lock the ~~lap belt or lap belt pelvic restraint~~ portion of the seat belt assembly shall not require any inverting, twisting or otherwise deforming of the seat belt assembly webbing.
- (b) If the means provided pursuant to S7.1.1.5(a) to lock the ~~lap belt or lap belt pelvic restraint~~ portion of any seat belt assembly makes it necessary for the vehicle user to take some action to activate the locking feature, the vehicle owner's manual shall include a description in words and/or diagrams describing how to activate the locking feature so that the seat belt assembly can tightly secure a child restraint system and how to deactivate the locking feature to remove the child restraint system.
- (c) Except for seat belt assemblies that have no retractor or that are equipped with an automatic locking retractor, compliance with S7.1.1.5(a) is demonstrated by the following procedure:
- (1) With the seat in any adjustment position, buckle the seat belt assembly. Complete any procedures recommended in the vehicle owner's manual, pursuant to S7.1.1.5(b), to activate any locking feature for the seat belt assembly.
 - (2) Locate a reference point A on the seat belt assembly ~~safety belt~~ buckle. Locate a reference point B on the attachment hardware or retractor assembly at the other end of the ~~lap belt or lap belt pelvic restraint~~ portion of the seat belt assembly. Adjust the ~~lap belt or lap belt pelvic restraint~~ portion of the seat belt assembly pursuant to S7.1.1.5(c)(1) as necessary so that the webbing between points A and B is at the maximum length allowed by the seat belt assembly system. Measure and record the distance between points A and B along the longitudinal centerline of the webbing for the ~~lap belt or lap belt pelvic restraint~~ portion of the seat belt assembly.
 - (3) Readjust the seat belt assembly system so that the webbing between points A and B is at any length that is 127 mm (5 inches) or more shorter than the maximum length of the webbing.
 - (4) Apply a pre-load of 44.5 N (10 pounds), using the webbing tension pull device described in Figure 5 of this TSD standard, to the ~~lap belt or lap belt pelvic restraint~~ portion of the seat belt assembly in a vertical plane parallel to the longitudinal axis of the vehicle and passing through the seating reference point of the designated seating position whose seat belt assembly belt system is being tested. Apply the pre-load in a horizontal direction toward the front of the vehicle with a force application angle of not less than 5 degrees nor more than 15 degrees above the horizontal. Measure and record the length of belt between points A and B along the longitudinal centerline of the webbing for the ~~lap belt or lap belt pelvic restraint~~ portion of the seat belt assembly while the pre-load is being applied.

- (5) Apply a load of 222.4 N (50 pounds), using the webbing tension pull device described in Figure 5 of this TSD standard, to the ~~lap belt or lap belt pelvic restraint~~ portion of the seat belt assembly in a vertical plane parallel to the longitudinal axis of the vehicle and passing through the seating reference point of the designated seating position whose ~~seat belt assembly belt system~~ is being tested. The load is applied in a horizontal direction toward the front of the vehicle with a force application angle of not less than 5 degrees nor more than 15 degrees above the horizontal at an onset rate of not more than 222.4 N (50 pounds) per second. Attain the 222.4 N (50 pound) load in not more than 5 seconds. If webbing sensitive emergency locking ~~retractors retroactive~~ are installed as part of the ~~lap belt assembly or lap belt pelvic restraint~~ portion of the seat belt assembly, apply the load at a rate less than the threshold value for lock-up specified by the manufacturer. Maintain the 222.4 N (50 pound)-load for at least 5 seconds before the measurements specified in S7.1.1.5(c)(6) are obtained and recorded.
- (6) Measure and record the length of belt between points A and B along the longitudinal centerline of the webbing for the ~~lap belt or lap belt pelvic restraint~~ portion of the seat belt assembly.
- (7) The difference between the measurements recorded under S7.1.1.5(c) (6) and (4) shall not exceed 50.8 mm (2 inches).
- (8) The difference between the measurements recorded under S7.1.1.5(c) (6) and (2) shall be 76.2 mm (3 inches) or more.

S7.1.2 [CONTENT NOT REPRODUCED]

S7.1.2.1 [CONTENT NOT REPRODUCED]

S7.1.2.2 [CONTENT NOT REPRODUCED]

S7.1.2.3 [CONTENT NOT REPRODUCED]

S7.1.3 [CONTENT NOT REPRODUCED]

S7.1.4 [CONTENT NOT REPRODUCED]

S7.1.5 [CONTENT NOT REPRODUCED]

S7.2 Latch mechanism

Except as provided in S7.2(e), each seat belt assembly installed in any vehicle shall have a latch mechanism that complies with the requirements specified in S7.2(a) through (d).

- (a) The components of the latch mechanism shall be accessible to a seated occupant in both the stowed and operational positions;
- (b) The latch mechanism shall release both the upper torso restraint and the ~~lap belt pelvic restraint~~ simultaneously, if the seat belt assembly has a ~~lap belt pelvic restraint~~ and an upper torso restraint that require unlatching for release of the occupant;

- (c) The latch mechanism shall release at a single point; and;
- (d) The latch mechanism shall release by a pushbutton action.
- (e) The requirements of S7.2 do not apply to any automatic belt assembly. ~~The requirements specified in S7.2(a) through (c) do not apply to any safety belt assembly installed at a forward-facing rear outboard seating position in a law enforcement vehicle.~~

S7.3

- (a) A seat belt assembly provided at the driver's designated seating position shall be equipped with a warning system that, at the option of the manufacturer, either—
 - (1) Activates a continuous or intermittent audible signal for a period of not less than 4 seconds and not more than 8 seconds and that activates a continuous or flashing warning light visible to the driver displaying the identifying symbol for the seat belt tell-tale shown in Table 2 of section 101 of Schedule IV of the MVSR FMVSS 101 or, ~~at the option of the manufacturer if permitted by FMVSS 101,~~ displaying the words “Fasten Seat Belts” or “Fasten Belts”, for not less than 60 seconds (beginning when the vehicle ignition switch is moved to the “on” or the “start” position) when condition (b) exists simultaneously with condition (c), or that
 - (2) Activates, for a period of not less than 4 seconds and not more than 8 seconds (beginning when the vehicle ignition switch is moved to the “on” or the “start” position), a continuous or flashing warning light visible to the driver, displaying the identifying symbol of the seat belt tell-tale shown in Table 2 of section 101 of Schedule IV of the MVSR FMVSS 101 or, ~~at the option of the manufacturer if permitted by FMVSS 101,~~ displaying the words “Fasten Seat Belts” or “Fasten Belts”, when condition (b) exists, and a continuous or intermittent audible signal when condition (b) exists simultaneously with condition (c).
- (b) The vehicle's ignition switch is moved to the “on” position or to the “start” position.
- (c) The driver's ~~lap belt~~ pelvic restraint is not in use, as determined, at the option of the manufacturer, either by the belt latch mechanism not being fastened, or by the belt not being extended at least 101.6 mm (4 inches) from its stowed position.

S7.4 Seat belt comfort and convenience

- (a) [CONTENT NOT REPRODUCED]
- (b) *Manual seat belts.*
 - (1) [CONTENT NOT REPRODUCED]
 - (2) *Vehicles manufactured after September 1, 1989.*
 - (i) [CONTENT NOT REPRODUCED]
 - (ii) Manual seat belts assemblies installed in a bus, multi-purpose passenger vehicle and truck with a gross vehicle weight rating of 4 536 kg (10,000 pounds) or less, except for walk-in vans ~~van-type vehicles~~, shall meet the requirements of S7.4.3, S7.4.4, S7.4.5, and S7.4.6.

S7.4.1 [CONTENT NOT REPRODUCED]

S7.4.2 *Webbing tension-relieving device.* Each vehicle with an automatic seat belt assembly or with a Type 2 manual seat belt assembly that must meet the occupant crash protection requirements of S5.1 of this ~~standard TSD~~ installed at a front outboard designated seating position, and each vehicle with a Type 2 manual seat belt assembly installed at a rear outboard designated seating position in compliance with a requirement of section 208 of Schedule IV of the MVSR ~~this standard~~, that has either automatic or manual tension-relieving devices permitting the introduction of slack in the webbing of the upper torso restraint ~~shoulder belt~~ (e.g., “comfort clips” or “window-shade” devices) shall:

- (a) Comply with the requirements of S5.1 with the upper torso restraint ~~shoulder belt~~ webbing adjusted to introduce the maximum amount of slack recommended by the vehicle manufacturer pursuant to S7.4.2(b).
- (b) Have a section in the vehicle owner's manual that explains how the tension-relieving device works and specifies the maximum amount of slack (~~in inches~~) recommended by the vehicle manufacturer to be introduced into the upper torso restraint ~~shoulder belt~~ under normal use conditions. The explanation shall also warn that introducing slack beyond the amount specified by the manufacturer could significantly reduce the effectiveness of the upper torso restraint ~~shoulder belt~~ in a crash; and
- (c) Have, except for open-body type vehicles with no doors, an automatic means to cancel any upper torso restraint ~~shoulder belt~~ slack introduced into the seat belt assembly system by a tension-relieving device. In the case of an automatic safety belt system, cancellation of the tension-relieving device shall occur each time the adjacent vehicle door is opened. In the case of a manual seat belt assembly required to meet S5.1, cancellation of the tension-relieving device shall occur, at the manufacturer's option, either each time the adjacent door is opened or each time the latchplate is released from the buckle. In the case of a Type 2 manual seat belt assembly installed at a rear outboard designated seating position, cancellation of the tension-relieving device shall occur, at the manufacturer's option either each time the door designed to

allow the occupant of that seating position entry and egress of the vehicle is opened or each time the latchplate is released from the buckle. In the case of open-body type vehicles with no doors, cancellation of the tension-relieving device may be done by a manual means.

S7.4.3 *Belt contact force.* Except for manual or automatic seat belt assemblies that incorporate a webbing tension-relieving device, the upper torso restraint webbing of any seat belt assembly shall not exert more than 3.1 N (0.7 pounds) of contact force when measured normal to and 25.4 mm (one inch) from the chest of an anthropomorphic test dummy, positioned in accordance with S10 of this TSD standard in the seating position for which that seat belt assembly is provided, at the point where the centerline of the upper torso restraint belt crosses the midsagittal line on the dummy's chest.

S7.4.4 *Latchplate access.* Any seat belt assembly latchplate that is located outboard of a front outboard designated seating position ~~in accordance with S4.1.2~~ shall also be located within the outboard reach envelope of either the outboard arm or the inboard arm described in S10.7 and Figure 3 of this TSD standard, when the latchplate is in its normal stowed position and any adjustable anchorages are adjusted to the manufacturer's nominal design position for a 50th percentile adult male occupant. There shall be sufficient clearance between the vehicle seat and the side of the vehicle interior to allow the test block defined in Figure 4 of this TSD standard unhindered transit to the latchplate or buckle.

S7.4.5 *Retraction.* When tested under the conditions of S8.1.2 and S8.1.3, with anthropomorphic dummies whose arms have been removed and which are positioned in accordance with S10 of this TSD standard in the front outboard designated seating positions and restrained by the seat belt assembly belt systems for those positions, the upper torso restraint and lap belt pelvic restraint webbing of any of those seat belt assemblies systems shall automatically retract to a stowed position either when the adjacent vehicle door is in the open position and the seat belt assembly latchplate is released, or, at the option of the manufacturer, when the latchplate is released. That stowed position shall prevent any part of the webbing or hardware from being pinched when the adjacent vehicle door is closed. A seat belt assembly belt system with a tension-relieving device in an ~~open-bodied~~ open body type vehicle with no doors shall fully retract when the tension-relieving device is deactivated. For the purposes of these retraction requirements, outboard armrests, which are capable of being stowed, on vehicle seats shall be placed in their stowed position.

S7.4.6 Seat belt assembly guides and hardware.

S7.4.6.1

- (a) Any manual seat belt assembly whose webbing is designed to pass through the seat cushion or between the seat cushion and seat back shall be designed to maintain one of the following three seat belt assembly parts (the seat belt assembly latchplate, the buckle, or the seat belt assembly webbing) on top of or above the seat cushion under normal conditions (i.e., conditions other than when belt hardware is intentionally pushed behind the seat by a vehicle occupant). In addition, the remaining two seat belt assembly parts must be accessible under normal conditions.

- (b) The requirements of S7.4.6.1(a) do not apply to: (1) seats whose seat cushions are movable so that the seat back serves a function other than seating, (2) seats which are removable, or (3) seats which are movable so that the space formerly occupied by the seat can be used for a secondary function.

S7.4.6.2 The buckle and latchplate of a manual seat belt assembly subject to S7.4.6.1 shall not pass through the guides or conduits provided for in S7.4.6.1 and fall behind the seat when the events listed below occur in the order specified: (a) The seat belt assembly is completely retracted or, if the seat belt assembly is nonretractable, the seat belt assembly is unlatched; (b) the seat is moved to any position to which it is designed to be adjusted; and (c) the seat back, if foldable, is folded forward as far as possible and then moved backward into position. The inboard receptacle end of a seat belt assembly installed at a front outboard designated seating position shall be accessible with the center arm rest in any position to which it can be adjusted (without having to move the armrest).

S8. Test conditions

S8.1 General conditions

The following conditions apply to the frontal, ~~lateral, and rollover~~ tests. ~~Except for S8.1.1(d), the following conditions apply to the alternative unbelted sled test set forth in S13 from March 19, 1997 until September 1, 2001.~~

S8.1.1 Except as provided in paragraph (c) of S8.1.1, the vehicle, including test devices and instrumentation, is loaded as follows:

- (a) *Passenger cars.* A passenger car is loaded to its unloaded vehicle weight plus its rated cargo-carrying and luggage capacity weight, secured in the luggage area, plus the weight of the necessary anthropomorphic test devices.
- (b) *Multi-purpose passenger vehicles, trucks, and buses.* A multi-purpose passenger vehicle, truck, or bus is loaded to its unloaded vehicle weight plus 136 kg (300 pounds) or its rated cargo-carrying and luggage capacity weight, whichever is less, secured in the load carrying area and distributed as nearly as possible in proportion to its gross axle weight ratings, plus the weight of the necessary anthropomorphic test devices. For the purposes of §8.1.1, unloaded vehicle weight does not include the weight of work-performing accessories. Vehicles are tested to a maximum unloaded vehicle weight of 2 495 kg (5,500 pounds).
- (c) *Fuel system capacity.* With the test vehicle on a level surface, pump the fuel from the vehicle's fuel tank and then operate the engine until it stops. Then, add Stoddard solvent to the test vehicle's fuel tank in an amount which is equal to not less than 92 and not more than 94 percent of the fuel tank's usable capacity stated by the vehicle's manufacturer. In addition, add the amount of Stoddard solvent needed to fill the entire fuel system from the fuel tank through the engine's induction system.
- (d) *Vehicle test attitude.* Determine the distance between a level surface and a standard reference point on the test vehicle's body, directly above each wheel opening, when

the vehicle is in its “as delivered” condition. The “as delivered” condition is the vehicle as received at the test site, with 100 percent of all fluid capacities and all tires inflated to the manufacturer's specifications as listed on the vehicle's tire placard. Determine the distance between the same level surface and the same standard reference points in the vehicle's “fully loaded condition.” The “fully loaded condition” is the test vehicle loaded in accordance with S8.1.1 (a) or (b), as applicable. The load placed in the cargo area shall be center over the longitudinal centerline of the vehicle. The pretest vehicle attitude shall be equal to either the as delivered or fully loaded attitude or between the as delivered attitude and the fully loaded attitude.

S8.1.2 Adjustable seats are in the adjustment position midway between the forwardmost and rearmost positions, and if separately adjustable in a vertical direction, are at the lowest position. If an adjustment position does not exist midway between the forwardmost and rearmost positions, the closest adjustment position to the rear of the midpoint is used.

S8.1.3 Place adjustable seat backs in the manufacturer's nominal design riding position in the manner specified by the manufacturer. Place any adjustable anchorages at the manufacturer's nominal design position for a 50th percentile adult male occupant. Place each adjustable head restraint in its highest adjustment position. Adjustable lumbar supports are positioned so that the lumbar support is in its lowest adjustment position.

S8.1.4 Adjustable steering controls are adjusted so that the steering wheel hub is at the geometric center of the locus it describes when it is moved through its full range of driving positions.

S8.1.5 Movable vehicle windows and vents are placed in the fully closed position, unless the vehicle manufacturer chooses to specify a different adjustment position prior to the time it certifies the vehicle.

S8.1.6 Convertibles and open-body type vehicles have the top, if any, in place in the closed ~~passenger~~ occupant compartment configuration.

S8.1.7 Doors are fully closed and latched but not locked.

S8.1.8 *Anthropomorphic test dummies.*

S8.1.8.1 [CONTENT NOT REPRODUCED]

S8.1.8.2 Each test dummy is clothed in a form fitting cotton stretch short sleeve shirt with above-the-elbow sleeves and above-the-knee length pants. The weight of the shirt or pants shall not exceed 113 g (0.25 pounds) each. Each foot of the test dummy is equipped with a size 11XW shoe which meets the configuration size, sole, and heel thickness specifications of MIL-S-13192P (~~incorporated by reference~~, see list at 49 CFR Part §571.5 paragraph (e) for the full citation) change “P” and whose weight is 567±90.7g (1.25 ±0.2 pounds).

S8.1.8.3 Limb joints are set at 1g, barely restraining the weight of the limb when extended horizontally. Leg joints are adjusted with the torso in the supine position.

S8.1.8.4 Instrumentation does not affect the motion of the dummies during impact or rollover.

S8.1.8.5 The stabilized test temperature of the test dummy is at any temperature level between 20.6 degrees C and 22.2 degrees C (69 degrees F and 72 degrees F), inclusive.

S8.2 [CONTENT NOT REPRODUCED]

S8.3 [CONTENT NOT REPRODUCED]

S8.4 Frontal test condition

If the vehicle is equipped with a cutoff device permitted by S4.5.4 of this TSD standard, the device is deactivated.

S9. [CONTENT NOT REPRODUCED]

S10. Test dummy positioning procedures

S10.1 Head

The transverse instrumentation platform of the head shall be level within 1/2 degree. To level the head of the test dummy, the following sequences must be followed. First, adjust the position of the H point within the limits set forth in S10.4.2.1 to level the transverse instrumentation platform of the head of the test dummy. If the transverse instrumentation platform of the head is still not level, then adjust the pelvic angle of the test dummy within the limits specified in S10.4.2.2 of this TSD standard. If the transverse instrumentation platform of the head is still not level, then adjust the neck bracket of the dummy the minimum amount necessary from the non-adjusted "0" setting to ensure that the transverse instrumentation platform of the head is horizontal within 1/2 degree. The test dummy shall remain within the limits specified in S10.4.2.1 and S10.4.2.2. after any adjustment of the neck bracket.

S10.2 Upper Arms

S10.2.1 The driver's upper arms shall be adjacent to the torso with the centerlines as close to a vertical plane as possible.

S10.2.2 The passenger's upper arms shall be in contact with the seat back and the sides of the torso.

S10.3 Hands

S10.3.1 The palms of the drivers test dummy shall be in contact with the outer part of the steering wheel rim at the rim's horizontal centerline. The thumbs shall be over the steering wheel rim and shall be lightly taped to the steering wheel rim so that if the hand of the test dummy is pushed upward by a force of not less than 907 g (2 pounds) and not more than 2.27 kg (5 pounds), the tape shall release the hand from the steering wheel rim.

S10.3.2 The palms of the passenger test dummy shall be in contact with the outside of the thigh. The little finger shall be in contact with the seat cushion.

S10.4 Torso

S10.4.1 *Upper Torso.*

S10.4.1.1 In vehicles equipped with bench seats, the upper torso of the driver and passenger test dummies shall rest against the seat back. The midsagittal plane of the driver dummy shall be vertical and parallel to the vehicle's longitudinal centerline, and pass through the center of the steering wheel rim. The midsagittal plane of the passenger dummy shall be vertical and parallel to the vehicle's longitudinal centerline and the same distance from the vehicle's longitudinal centerline as the midsagittal plane of the driver dummy.

S10.4.1.2 In vehicles equipped with bucket seats, the upper torso of the driver and passenger test dummies shall rest against the seat back. The midsagittal plane of the driver and the passenger dummy shall be vertical and shall coincide with the longitudinal centerline of the bucket seat.

S10.4.2 *Lower Torso.*

S10.4.2.1 *H-point.* The H-points of the driver and passenger test dummies shall coincide within 12.7 mm (1/2inch) in the vertical dimension and 12.7 mm (1/2inch) in the horizontal dimension of a point 6.35 mm (1/4inch) below the position of the H-point determined by using the equipment and procedures specified in SAE J826-1980 (~~incorporated by reference, see the list at 49 CFR Part §571.5 paragraph (k) for the full citation~~) except that the length of the lower leg and thigh segments of the H-point machine shall be adjusted to 414 mm and 401.3 mm (16.3 and 15.8 inches), respectively, instead of the 50th percentile values specified in Table 1 of SAE J826.

S10.4.2.2 *Pelvic angle.* As determined using the pelvic angle gage (GM drawing 78051-532, incorporated by reference in 49 CFR part 572, subpart E ~~of this chapter~~) which is inserted into the H-point gaging hole of the dummy, the angle measured from the horizontal on the 76.2mm (three inch) flat surface of the gage shall be $21\frac{1}{2}$ degrees plus or minus $21\frac{1}{2}$ degrees.

S10.5 Legs

The upper legs of the driver and passenger test dummies shall rest against the seat cushion to the extent permitted by placement of the feet. The initial distance between the outboard knee clevis flange surfaces shall be 269.2 mm (10.6 inches). To the extent practicable, the left leg of the driver dummy and both legs of the passenger dummy shall be in vertical longitudinal planes. To the extent practicable, the right leg of the driver dummy shall be in a vertical plane. Final adjustment to accommodate the placement of feet in accordance with S10.6 for various ~~passenger~~ occupant compartment configurations is permitted.

S10.6 Feet

S10.6.1 *Driver's position.*

S10.6.1.1 If the vehicle has an adjustable accelerator pedal, adjust it to the full forward position. Rest the right foot of the test dummy on the undepressed accelerator pedal with the rearmost point of the heel on the floor pan in the plane of the pedal. If the foot cannot be placed on the accelerator pedal, set it initially perpendicular to the lower leg and then place it as far forward as possible in the direction of the pedal centerline with the rearmost point of the heel resting on the floor pan. If the vehicle has an adjustable accelerator pedal and the right foot is not touching the accelerator pedal when positioned as above, move the pedal rearward until it touches the right foot. If the accelerator pedal still does not touch the foot in the full rearward position, leave the pedal in that position.

S10.6.1.2 Place the left foot on the toeboard with the rearmost point of the heel resting on the floor pan as close as possible to the point of intersection of the planes described by the toeboard and the floor pan and not on the wheelwell projection. If the foot cannot be positioned on the toeboard, set it initially perpendicular to the lower leg and place it as far forward as possible with the heel resting on the floor pan. If necessary to avoid contact with the vehicle's brake or clutch pedal, rotate the test dummy's left foot about the lower leg. If there is still pedal interference, rotate the left leg outboard about the hip the minimum distance necessary to avoid the pedal interference. For vehicles with a foot rest that does not elevate the left foot above the level of the right foot, place the left foot on the foot rest so that the upper and lower leg centerlines fall in a vertical plane.

S10.6.2 *Passenger's position.*

S10.6.2.1 *Vehicles with a flat floor pan/toeboard.* Place the right and left feet on the vehicle's toeboard with the heels resting on the floor pan as close as possible to the intersection point with the toeboard. If the feet cannot be placed flat on the toeboard, set them perpendicular to the lower leg centerlines and place them as far forward as possible with the heels resting on the floor pan.

S10.6.2.2 *Vehicles with wheelhouse projections in ~~passenger~~ occupant compartment.* Place the right and left feet in the well of the floor pan/toeboard and not on the wheelhouse projection. If the feet cannot be placed flat on the toeboard, initially set them perpendicular to the lower leg centerlines and then place them as far forward as possible with the heels resting on the floor pan.

S10.7 Test dummy positioning for latchplate access

The reach envelopes specified in S7.4.4 of this ~~TSD standard~~ are obtained by positioning a test dummy in the driver's or passenger's seating position and adjusting that seating position to its forwardmost adjustment position. Attach the lines for the inboard and outboard arms to the test dummy as described in Figure 3 of this ~~TSD standard~~. Extend each line backward and outboard to generate the compliance arcs of the outboard reach envelope of the test dummy's arms.

S10.8 Test dummy positioning for belt contact force

To determine compliance with S7.4.3 of this ~~TSD standard~~, position the test dummy in the vehicle in accordance with S10.1 through S10.6 of this ~~TSD standard~~ and adjust the seating position in accordance with S8.1.2 and S8.1.3 of this ~~TSD standard~~. Pull the seat belt assembly webbing 76.2 mm (three inches) from the test dummy's chest and release until the webbing is within 25.4 mm (one inch) of the test dummy's chest and measure the belt contact force.

S10.9 Manual belt adjustment for dynamic testing

With the test dummy positioned in accordance with S10.1 through S10.6 of this ~~TSD standard~~ and the seating position adjusted in accordance with S8.1.2 and S8.1.3 of this ~~TSD standard~~, place the Type 2 manual seat belt assembly around the test dummy and fasten the latch. Remove all slack from the ~~lap belt pelvic restraint~~ portion. Pull the upper torso restraint webbing out of the retractor and allow it to retract; repeat this four times. Apply a 8.9 to 17.8 N (2 to 4 pound) tension load to the ~~lap belt pelvic restraint~~. If the seat belt assembly belt system is equipped with a tension-relieving device, introduce the maximum amount of slack into the upper torso restraint belt that is recommended by the vehicle manufacturer in the vehicle's owner's manual. If the seat belt assembly belt system is not equipped with a tension-relieving device, allow the excess webbing in the upper torso restraint belt to be retracted by the retractive force of the retractor.

S11. [Reserved]

S12. [CONTENT NOT REPRODUCED]

S13. [CONTENT NOT REPRODUCED]

~~**S14. Advanced air bag requirements for passenger cars and for trucks, buses, and multi-purpose passenger vehicles with a GVWR of 3,855 kg (8500 pounds) or less and an unloaded vehicle weight of 2,495 kg (5500 pounds) or less, except for walk-in van-type trucks or vehicles designed to be sold exclusively to the U.S. Postal Service.**~~

S14.1 [CONTENT NOT REPRODUCED]**S14.2 [CONTENT NOT REPRODUCED]****S14.3 [CONTENT NOT REPRODUCED]****S14.4 Vehicles manufactured on or after September 1, 2010**

Each vehicle shall meet the requirements specified in S14.5.1(b), ~~S14.5.2~~, S15.1, ~~S15.2~~, S17, S19, S21, S23, and S25 (in addition to the other requirements specified in this TSD standard).

S14.5 Fixed collision-B barrier test requirements using 50th percentile adult male dummies.**S14.5.1 Fixed collision ~~Rigid~~-barrier belted test.**

(a) [CONTENT NOT REPRODUCED]

(b) Each vehicle that is conforms to ~~certified as complying with S14.3 or~~ S14.4 shall, at each front outboard designated seating position, meet the injury criteria specified in S6.1, S6.2(b), ~~S6.3~~, S6.4(b), S6.5, and S6.6 when tested under S5.1.1(b)(2).

S14.5.2 [CONTENT NOT REPRODUCED]**S14.6 [CONTENT NOT REPRODUCED]**

S14.7 *Vehicles manufactured on or after September 1, 2012.-(Higher maximum speed (56km/h (35 mph)) belted test requirement using 5th percentile adult female dummies).* Each vehicle shall meet the requirements specified in S15.1(b) (in addition to the other requirements specified in this TSD standard). However, vehicles that are manufactured in two or more stages or that are altered (within the meaning of Chapter V, Title 49, part 567.7 of the Code of Federal Regulations 49 CFR 567.7) after having been previously certified in accordance with Chapter V, Title 49, part 567 of the Code of Federal Regulations part 567 of this chapter may comply with the requirements specified in S15.1(a) instead of S15.1(b), if they are manufactured before September 1, 2013.

S14.8 [CONTENT NOT REPRODUCED]**S15. Fixed collision-Rigid barrier test requirements using 5th percentile adult female dummies**

S15.1 Belted Test

- (a) [CONTENT NOT REPRODUCED]
- (b) Each vehicle that ~~is conforms certified as complying with S14.6 or S14.7~~ shall, at each front outboard designated seating position, meet the injury criteria specified in S15.3 when tested under S16.1(a)(2).

S15.2 [CONTENT NOT REPRODUCED]

S15.3 *Injury criteria for the 49 CFR part 572, subpart O Hybrid III 5th percentile female test dummy.*

S15.3.1 All portions of the test dummy shall be contained within the outer surfaces of the vehicle ~~passenger~~ occupant compartment.

S15.3.2 *Head injury criteria*

- (a) For any two points in time, t_1 and t_2 , during the event which are separated by not more than a 15 millisecond time interval and where t_1 is less than t_2 , the head injury criterion (HIC_{15}) shall be determined using the resultant head acceleration at the center of gravity of the dummy head, a_r , expressed as a multiple of g (the acceleration of gravity) and shall be calculated using the expression:

$$\left[\frac{1}{(t_2 - t_1)} \int_{t_1}^{t_2} a_r dt \right]^{2.5} (t_2 - t_1)$$

- (b) The maximum calculated HIC_{15} value shall not exceed 700.

S15.3.3 [CONTENT NOT REPRODUCED]

S15.3.4 Compression deflection of the sternum relative to the spine, as determined by instrumentation, shown shall not exceed 52 mm (2.0 in).²

S15.3.5 The force transmitted axially through each femur shall not exceed 6805 N (1530 lb).

² Please see subsection 208(23) of Schedule IV of the MVSR, which modifies the requirement

S15.3.6 Neck injury. When measuring neck injury, each of the following injury criteria shall be met.

(a) *Nij*.

- (1) The shear force (F_x), axial force (F_z), and bending moment (M_y) shall be measured by the dummy upper neck load cell for the duration of the crash event as specified in S4.11. Shear force, axial force, and bending moment shall be filtered for *Nij* purposes at SAE Recommended Practice J211/1 MAR95 (~~incorporated by reference~~, see the list at 49 CFR Part §571.5 paragraph (k) for the full citation) Channel Frequency Class 600.
- (2) During the event, the axial force (F_z) can be either in tension or compression while the occipital condyle bending moment (M_{ocy}) can be in either flexion or extension. This results in four possible loading conditions for *Nij*: Tension-extension (N_{te}), tension-flexion (N_{tf}), compression-extension (N_{ce}), or compression-flexion (N_{cf}).
- (3) When calculating *Nij* using equation S15.3.6(a)(4), the critical values, F_{zc} and M_{yc} , are:
 - (i) $F_{zc} = 4287 \text{ N (964 lbf)}$ when F_z is in tension
 - (ii) $F_{zc} = 3880 \text{ N (872 lbf)}$ when F_z is in compression
 - (iii) $M_{yc} = 155 \text{ Nm (114 lbf-ft)}$ when a flexion moment exists at the occipital condyle
 - (iv) $M_{yc} = 67 \text{ Nm (49 lbf-ft)}$ when an extension moment exists at the occipital condyle.
- (4) At each point in time, only one of the four loading conditions occurs and the *Nij* value corresponding to that loading condition is computed and the three remaining loading modes shall be considered a value of zero. The expression for calculating each *Nij* loading condition is given by:

$$N_{ij} = (F_z/F_{zc}) + (M_{ocy}/M_{yc})$$

(5) None of the four *Nij* values shall exceed 1.0 at any time during the event.

- (b) *Peak tension.* Tension force (F_z), measured at the upper neck load cell, shall not exceed 2620 N (589 lbf) at any time.
- (c) *Peak compression.* Compression force (F_z), measured at the upper neck load cell, shall not exceed 2520 N (566 lbf) at any time.

S15.3.7 Unless otherwise indicated, instrumentation for data acquisition, data channel frequency class, and moment calculations are the same as given for the 49 CFR part 572, subpart O Hybrid III 5th percentile female test dummy.

S16. Test procedures for rigid fixed collision barrier test requirements using 5th percentile adult female dummies

S16.1 General provisions

Crash testing to determine compliance with the requirements of S15 of this TSD standard is conducted as specified in ~~the following paragraphs (a) and (b)~~.

(a) *Belted test* —

(1) [CONTENT NOT REPRODUCED]

(2) *Vehicles conforming ~~certified to S14.6 or S14.7~~*. Place a 49 CFR Part 572 Subpart O 5th percentile adult female test dummy at each front outboard designated seating position of a vehicle, in accordance with the procedures specified in S16.3 of this TSD standard. Impact the vehicle traveling longitudinally forward at any speed, up to and including 56km/h (35 mph), into a fixed collision ~~rigid~~ barrier that is perpendicular within a tolerance of ± 5 degrees to the line of travel of the vehicle under the applicable conditions of S16.2 of this TSD standard.

(b) [CONTENT NOT REPRODUCED]

S16.2 Test conditions

S16.2.1 The vehicle, including test devices and instrumentation, is loaded as in S8.1.1.

S16.2.2 Movable vehicle windows and vents are placed in the fully closed position, unless the vehicle manufacturer chooses to specify a different adjustment position prior to the time the vehicle is tested ~~certified~~.

S16.2.3 Convertibles and open-body type vehicles have the top, if any, in place in the closed passenger occupant compartment configuration.

S16.2.4 Doors are fully closed and latched but not locked.

S16.2.5 The dummy is clothed in form fitting cotton stretch garments with short sleeves and above the knee length pants. A size 7 1/2W shoe which meets the configuration and size specifications of MIL-S-21711E (~~incorporated by reference~~, see the list at 49 CFR Part §571.5 paragraph (e) for the full citation) or its equivalent is placed on each foot of the test dummy.

S16.2.6 Limb joints are set at one g, barely restraining the weight of the limb when extended horizontally. Leg joints are adjusted with the torso in the supine position.

S16.2.7 Instrumentation shall not affect the motion of dummies during impact.

S16.2.8 The stabilized temperature of the dummy is at any level between 20.6 °C and 22.2 °C (69 °F to 72 °F).

S16.2.9 *Steering wheel adjustment.*

S16.2.9.1 Adjust a tiltable steering wheel, if possible, so that the steering wheel hub is at the geometric center of its full range of driving positions.

S16.2.9.2 If there is no setting detent at the mid-position, lower the steering wheel to the detent just below the mid-position.

S16.2.9.3 If the steering column is telescoping, place the steering column in the mid-position. If there is no mid-position, move the steering wheel rearward one position from the mid-position.

S16.2.10 *Driver and passenger seat set-up.*

S16.2.10.1 *Lumbar support adjustment.* Position adjustable lumbar supports so that the lumbar support is in its lowest, retracted or deflated adjustment position.

S16.2.10.2 *Other seat adjustments.* Position any adjustable parts of the seat that provide additional support so that they are in the lowest or most open adjustment position. Position any adjustable head restraint in the lowest and most forward position.

S16.2.10.3 *Seat position adjustment.* If the passenger seat does not adjust independently of the driver seat, the driver seat shall control the final position of the passenger seat.

S16.2.10.3.1 Using only the controls that primarily move the seat and seat cushion independent of the seat back in the fore and aft directions, move the seat cushion reference point (SCRCP) to the rearmost position. Using any part of any control, other than those just used, determine the full range of angles of the seat cushion reference line and set the seat cushion reference line to the middle of the range. Using any part of any control other than those that primarily move the seat or seat cushion fore and aft, while maintaining the seat cushion reference line angle, place the SCRCP to its lowest position.

S16.2.10.3.2 Using only the control that primarily moves the seat fore and aft, move the SCRCP to the full forward position.

S16.2.10.3.3 If the seat or seat cushion height is adjustable, other than by the controls that primarily move the seat or seat cushion fore and aft, determine the maximum and minimum heights of the SCRCP, while maintaining, as closely as possible, the angle determined in S16.2.10.3.1. Set the SCRCP at the midpoint height with the seat cushion reference line angle set as closely as possible to the angle determined in S16.2.10.3.1. Mark location of the seat for future reference.

S16.3 Dummy seating positioning procedures

The 49 CFR Part 572 Subpart O 5th percentile adult female test dummy is positioned as follows:

S16.3.1 *General provisions and definitions.*

S16.3.1.1 All angles are measured with respect to the horizontal plane unless otherwise stated.

S16.3.1.2 The dummy's neck bracket is adjusted to align the zero degree index marks.

S16.3.1.3 The term "midsagittal plane" refers to the vertical plane that separates the dummy into equal left and right halves.

S16.3.1.4 The term "vertical longitudinal plane" refers to a vertical plane parallel to the vehicle's longitudinal centerline.

S16.3.1.5 The term "vertical plane" refers to a vertical plane, not necessarily parallel to the vehicle's longitudinal centerline.

S16.3.1.6 The term "transverse instrumentation platform" refers to the transverse instrumentation surface inside the dummy's skull casting to which the neck load cell mounts. This surface is perpendicular to the skull cap's machined inferior-superior mounting surface.

S16.3.1.7 The term "thigh" refers to the femur between, but not including, the knee and the pelvis.

S16.3.1.8 The term "leg" refers to the lower part of the entire leg, including the knee.

S16.3.1.9 The term "foot" refers to the foot, including the ankle.

S16.3.1.10 The longitudinal centerline of a bucket seat cushion is defined by a vertical plane that passes through the SgRP and is parallel to the longitudinal centerline of the vehicle.

S16.3.1.11 For leg and thigh angles, use the following references:

S16.3.1.11.1 *Thigh*—a straight line on the thigh skin between the center of the 1/2–13 UNC–2B tapped hole in the upper leg femur clamp (see drawings 880105–504 (left thigh) and 880105–505 (right thigh), upper leg femur clamp) and the knee pivot shoulder bolt (part 880105–527 in drawing 880105–528R & 528L, sliding knee assembly without potentiometer).

S16.3.1.11.2 *Leg*—a straight line on the leg skin between the center of the ankle shell (parts 880105–609 & 633 in drawing 880105–660, ankle assembly) and the knee pivot shoulder bolt (part 880105–527 in drawing 880105–528R & 528L, sliding knee assembly without potentiometer).

S16.3.1.12 The term "seat cushion reference point" (SCRCP) means a point placed on the outboard side of the seat cushion at a horizontal distance between 150 mm (5.9 in) and 250 mm (9.8 in) from the front edge of the seat used as a guide in positioning the seat.

S16.3.1.13 The term "seat cushion reference line" means a line on the side of the seat cushion, passing through the seat cushion reference point, whose projection in the vehicle vertical longitudinal plane is straight and has a known angle with respect to the horizontal.

S16.3.2 Driver dummy positioning.**S16.3.2.1 Driver torso/head/seat back angle positioning.**

S16.3.2.1.1 With the seat in the position determined in S16.2.10.3.3, use only the control that primarily moves the seat fore and aft to place the seat in the rearmost position. If the seat cushion reference line angle automatically changes as the seat is moved from the full forward position, maintain, as closely as possible, the seat cushion reference line angle determined in S16.2.10.3.1, for the final forward position when measuring the pelvic angle as specified in S16.3.2.1.11. The seat cushion reference angle position may be achieved through the use of any seat or seat cushion adjustments other than that which primarily moves the seat or seat cushion fore-aft.

S16.3.2.1.2 Fully recline the seat back, if adjustable. Install the dummy into the driver's seat, such that when the legs are positioned 120 degrees to the thighs, the calves of the legs are not touching the seat cushion.

S16.3.2.1.3 Bucket seats. Place the dummy on the seat cushion so that its midsagittal plane is vertical and coincides with the vertical longitudinal plane through the center of the seat cushion, within ± 10 mm (± 0.4 in).

S16.3.2.1.4 Bench seats. Position the midsagittal plane of the dummy vertical and parallel to the vehicle's longitudinal centerline and aligned within ± 10 mm (± 0.4 in) of the center of the steering wheel rim.

S16.3.2.1.5 Hold the dummy's thighs down and push rearward on the upper torso to maximize the dummy's pelvic angle.

S16.3.2.1.6 Place the legs at 120 degrees to the thighs. Set the initial transverse distance between the longitudinal centerlines at the front of the dummy's knees at 160 to 170 mm (6.3 to 6.7 in), with the thighs and legs of the dummy in vertical planes. Push rearward on the dummy's knees to force the pelvis into the seat so there is no gap between the pelvis and the seat back or until contact occurs between the back of the dummy's calves and the front of the seat cushion.

S16.3.2.1.7 Gently rock the upper torso laterally in a side to side motion three times through a ± 5 degree arc (approximately 51 mm (2 in) side to side).

S16.3.2.1.8 If needed, extend the legs slightly so that the feet are not in contact with the floor pan. Let the thighs rest on the seat cushion to the extent permitted by the foot movement. Keeping the leg and the thigh in a vertical plane, place the foot in the vertical longitudinal plane that passes through the centerline of the accelerator pedal. Rotate the left thigh outboard about the hip until the center of the knee is the same distance from the midsagittal plane of the dummy as the right knee ± 5 mm (± 0.2 in). Using only the control that primarily moves the seat fore and aft, attempt to return the seat to the full forward position. If either of the dummy's legs first contacts the steering wheel, then adjust the steering wheel, if adjustable, upward until contact with the steering wheel is avoided. If the steering wheel is not adjustable, separate the knees enough to avoid steering wheel contact. Proceed with moving the seat forward until either the leg contacts the vehicle interior or the seat reaches the full forward position. (The right foot may contact and depress the accelerator and/or

change the angle of the foot with respect to the leg during seat movement.) If necessary to avoid contact with the vehicle's brake or clutch pedal, rotate the test dummy's left foot about the leg. If there is still interference, rotate the left thigh outboard about the hip the minimum distance necessary to avoid pedal interference. If a dummy leg contacts the vehicle interior before the full forward position is attained, position the seat at the next detent where there is no contact. If the seat is a power seat, move the seat fore and aft to avoid contact while assuring that there is a maximum of 5 mm (0.2 in) distance between the vehicle interior and the point on the dummy that would first contact the vehicle interior. If the steering wheel was moved, return it to the position described in S16.2.9. If the steering wheel contacts the dummy's leg(s) prior to attaining this position, adjust it to the next higher detent, or if infinitely adjustable, until there is 5 mm (0.2 in) clearance between the wheel and the dummy's leg(s).

S16.3.2.1.9 For vehicles without adjustable seat backs, adjust the lower neck bracket to level the head as much as possible. For vehicles with adjustable seat backs, while holding the thighs in place, rotate the seat back forward until the transverse instrumentation platform of the head is level to within ± 0.5 degree, making sure that the pelvis does not interfere with the seat belt. Inspect the abdomen to ensure that it is properly installed. If the torso contacts the steering wheel, adjust the steering wheel in the following order until there is no contact: telescoping adjustment, lowering adjustment, raising adjustment. If the vehicle has no adjustments, or contact with the steering wheel cannot be eliminated by adjustment, position the seat at the next detent where there is no contact with the steering wheel as adjusted in S16.2.9. If the seat is a power seat, position the seat to avoid contact while assuring that there is a maximum of 5 mm (0.2 in) distance between the steering wheel as adjusted in S16.2.9 and the point of contact on the dummy.

S16.3.2.1.10 If it is not possible to achieve the head level within ± 0.5 degrees, minimize the angle.

S16.3.2.1.11 Measure and set the dummy's pelvic angle using the pelvic angle gauge (drawing TE-2504, ~~incorporated by reference~~ referred to in 49 CFR part 572, subpart O of ~~this chapter~~). The angle shall be set to 20.0 degrees ± 2.5 degrees. If this is not possible, adjust the pelvic angle as close to 20.0 degrees as possible while keeping the transverse instrumentation platform of the head as level as possible by adjustments specified in S16.3.2.1.9 and S16.3.2.1.10.

S16.3.2.1.12 If the dummy is contacting the vehicle interior after these adjustments, using only the control that primarily moves the seat fore and aft, move the seat rearward until there is a maximum of 5 mm (0.2 in) between the contact point of the dummy and the interior of the vehicle or if it has a manual seat adjustment, to the next rearward detent position. If after these adjustments, the dummy contact point is more than 5 mm (0.2 in) from the vehicle interior and the seat is still not in its forwardmost position, move the seat forward until the contact point is a maximum of 5 mm (0.2 in) from the vehicle interior, or if it has a manual seat adjustment, move the seat to the closest detent position that causes no contact, or until the seat reaches its forwardmost position, whichever occurs first.

S16.3.2.2 *Driver foot positioning.*

S16.3.2.2.1 If the vehicle has an adjustable accelerator pedal, adjust it to the full forward position. If the heel of the right foot can contact the floor pan, follow the positioning procedure in (a). If not, follow the positioning procedure in (b).

- (a) Rest the right foot of the test dummy on the undepressed accelerator pedal with the rearmost point of the heel on the floor pan in the plane of the pedal. If the foot cannot be placed on the accelerator pedal, set it initially perpendicular to the leg and then place it as far forward as possible in the direction of the pedal centerline with the rearmost point of the heel resting on the floor pan. If the vehicle has an adjustable accelerator pedal and the right foot is not touching the accelerator pedal when positioned as above, move the pedal rearward until it touches the right foot. If the accelerator pedal in the full rearward position still does not touch the foot, leave the pedal in that position. Extend the foot and lower leg by decreasing the knee flexion angle until any part of the foot contacts the undepressed accelerator pedal. If the foot does not contact the pedal, place the highest part of the foot at the same height as the highest part of the pedal.
- (b) Extend the foot and lower leg by decreasing the knee flexion angle until any part of the foot contacts the undepressed accelerator pedal or the highest part of the foot is at the same height as the highest part of the pedal. If the vehicle has an adjustable accelerator pedal and the right foot is not touching the accelerator pedal when positioned as above, move the pedal rearward until it touches the right foot.

S16.3.2.2.2 If the ball of the right foot does not contact the pedal, increase the ankle plantar flexion angle such that the toe of the foot contacts or is as close as possible to contact with the undepressed accelerator pedal.

S16.3.2.2.3 If, in its final position, the heel is off of the vehicle floor, a spacer block must be used under the heel to support the final foot position (see Figure 13). The surface of the block in contact with the heel must have an inclination of 30 degrees, measured from the horizontal, with the highest surface towards the rear of the vehicle.

S16.3.2.2.4 Place the left foot on the toe-board with the rearmost point of the heel resting on the floor pan as close as possible to the point of intersection of the planes described by the toe-board and floor pan.

S16.3.2.2.5 If the left foot cannot be positioned on the toe board, place the foot perpendicular to the lower leg centerline as far forward as possible with the heel resting on the floor pan.

S16.3.2.2.6 If the left foot does not contact the floor pan, place the foot parallel to the floor and place the lower leg as perpendicular to the thigh as possible.

S16.3.2.2.7 When positioning the test dummy under S16.3.2.2.4, S16.3.2.2.5, and S16.2.2.6, avoid contact between the left foot of the test dummy and the vehicle's brake pedal, clutch pedal, wheel well projection, and foot rest. To avoid this contact, use the three foot position adjustments listed in paragraphs (a) through (c). The adjustment options are listed in priority order, with each subsequent option incorporating the previous. In making each adjustment, move the foot the minimum distance necessary to avoid contact. If it is not possible to avoid all prohibited foot contact, give priority to avoiding brake or clutch pedal contact.

- (a) Rotate (abduction/adduction) the test dummy's left foot about the lower leg,
- (b) Plantar flex the foot,
- (c) Rotate the left leg about the hip in either an outboard or inboard direction.

S16.3.2.3 *Driver arm/hand positioning.*

S16.3.2.3.1 Place the dummy's upper arms adjacent to the torso with the arm centerlines as close to a vertical longitudinal plane as possible.

S16.3.2.3.2 Place the palms of the dummy in contact with the outer part of the steering wheel rim at its horizontal centerline with the thumbs over the steering wheel rim.

S16.3.2.3.3 If it is not possible to position the thumbs inside the steering wheel rim at its horizontal centerline, then position them above and as close to the horizontal centerline of the steering wheel rim as possible.

S16.3.2.3.4 Lightly tape the hands to the steering wheel rim so that if the hand of the test dummy is pushed upward by a force of not less than 9 N (2 lb) and not more than 22 N (5 lb), the tape releases the hand from the steering wheel rim.

S16.3.3 *Passenger dummy positioning.*

S16.3.3.1 *Passenger torso/head/seat back angle positioning.*

S16.3.3.1.1 With the seat at the mid-height in the full forward position determined in S16.2.10.3.3, use only the control that primarily moves the seat fore and aft to place the seat in the rearmost position, without adjusting independent height controls. If the seat cushion reference line angle automatically changes as the seat is moved from the full forward position, maintain as closely as possible the seat cushion reference line angle in S16.2.10.3.1, for the final forward position when measuring the pelvic angle as specified in S16.3.3.1.11. The seat cushion reference line angle position may be achieved through the use of any seat or seat cushion adjustments other than that which primarily moves the seat or seat cushion fore-aft.

S16.3.3.1.2 Fully recline the seat back, if adjustable. Install the dummy into the passenger seat, such that when the legs are 120 degrees to the thighs, the calves of the legs are not touching the seat cushion.

S16.3.3.1.3 *Bucket seats.* Place the dummy on the seat cushion so that its midsagittal plane is vertical and coincides with the vertical longitudinal plane through the center of the seat cushion, within ± 10 mm (± 0.4 ~~in~~ ~~mm~~).

S16.3.3.1.4 *Bench seats.* Position the midsagittal plane of the dummy vertical and parallel to the vehicle's longitudinal centerline and the same distance from the vehicle's longitudinal centerline, within ± 10 mm (± 0.4 in), as the midsagittal plane of the driver dummy.

S16.3.3.1.5 Hold the dummy's thighs down and push rearward on the upper torso to maximize the dummy's pelvic angle.

S16.3.3.1.6 Place the legs at 120 degrees to the thighs. Set the initial transverse distance between the longitudinal centerlines at the front of the dummy's knees at 160 to 170 mm (6.3 to 6.7 in), with the thighs and legs of the dummy in vertical planes. Push rearward on the dummy's knees to force the pelvis into the seat so there is no gap between the pelvis and the seat back or until contact occurs between the back of the dummy's calves and the front of the seat cushion.

S16.3.3.1.7 Gently rock the upper torso laterally side to side three times through a ± 5 degree arc (approximately 51 mm (2 in) side to side).

S16.3.3.1.8 If needed, extend the legs slightly so that the feet are not in contact with the floor pan. Let the thighs rest on the seat cushion to the extent permitted by the foot movement. With the feet perpendicular to the legs, place the heels on the floor pan. If a heel will not contact the floor pan, place it as close to the floor pan as possible. Using only the control that primarily moves the seat fore and aft, attempt to return the seat to the full forward position. If a dummy leg contacts the vehicle interior before the full forward position is attained, position the seat at the next detent where there is no contact. If the seats are power seats, position the seat to avoid contact while assuring that there is a maximum of 5 mm (0.2 in) distance between the vehicle interior and the point on the dummy that would first contact the vehicle interior.

S16.3.3.1.9 For vehicles without adjustable seat backs, adjust the lower neck bracket to level the head as much as possible. For vehicles with adjustable seat backs, while holding the thighs in place, rotate the seat back forward until the transverse instrumentation platform of the head is level to within ± 0.5 degrees, making sure that the pelvis does not interfere with the seat bight. Inspect the abdomen to insure that it is properly installed.

S16.3.3.1.10 If it is not possible to orient the head level within ± 0.5 degrees, minimize the angle.

S16.3.3.1.11 Measure and set the dummy's pelvic angle using the pelvic angle gauge (drawing TE-2504, ~~incorporated by reference~~ referred to in 49 CFR Part 572, Subpart O, ~~of this chapter~~). The angle shall be set to 20.0 degrees ± 2.5 degrees. If this is not possible, adjust the pelvic angle as close to 20.0 degrees as possible while keeping the transverse instrumentation platform of the head as level as possible, as specified in S16.3.3.1.9 and S16.3.3.1.10.

S16.3.3.1.12 If the dummy is contacting the vehicle interior after these adjustments, using only the control that primarily moves the seat fore and aft, move the seat rearward until there is a maximum of 5 mm (0.2 in) between the contact point of the dummy and the interior of the vehicle or if it has a manual seat adjustment, to the next rearward detent position. If after these adjustments, the dummy contact point is more than 5 mm (0.2 in) from the vehicle interior and the seat is still not in its forwardmost position, move the seat forward until the contact point is a maximum of 5 mm (0.2 in) from the vehicle interior, or if it has a manual seat adjustment, move the seat to the closest detent position that causes no contact, or until the seat reaches its forwardmost position, whichever occurs first.

S16.3.3.2 *Passenger foot positioning.*

S16.3.3.2.1 Place the passenger's feet flat on the toe board.

S16.3.3.2.2 If the feet cannot be placed flat on the toe board, set them perpendicular to the leg centerlines and place them as far forward as possible with the heels resting on the floor pan. If either foot does not contact the floor pan, place the foot parallel to the floor pan and place the lower leg as perpendicular to the thigh as possible.

S16.3.3.3 *Passenger arm/hand positioning.*

S16.3.3.3.1 Place the dummy's upper arms in contact with the seat back and the torso.

S16.3.3.3.2 Place the palms of the dummy in contact with the outside of the thighs.

S16.3.3.3.3 Place the little fingers in contact with the seat cushion.

S16.3.4 *Driver and passenger adjustable head restraints.*

S16.3.4.1 If the head restraint has an automatic adjustment, leave it where the system positions the restraint after the dummy is placed in the seat.

S16.3.4.2 Adjust each head restraint to its lowest position.

S16.3.4.3 Measure the vertical distance from the top most point of the head restraint to the bottom most point. Locate a horizontal plane through the midpoint of this distance. Adjust each head restraint vertically so that this horizontal plane is aligned with the center of gravity (CG) of the dummy head.

S16.3.4.3 If the above position is not attainable, move the vertical center of the head restraint to the closest detent below the center of the head CG.

S16.3.4.4 If the head restraint has a fore and aft adjustment, place the restraint in the forwardmost position or until contact with the head is made, whichever occurs first.

S16.3.5 *Driver and passenger manual seat belt assembly adjustment (for tests conducted with a belted dummy)*

S16.3.5.1 If an adjustable seat belt assembly D-ring anchorage exists, place it in the manufacturer's design position for a 5th percentile adult female with the seat in the position specified in S16.2.10.3.

S16.3.5.2 Place the Type 2 manual seat belt assembly around the test dummy and fasten the latch.

S16.3.5.3 Ensure that the dummy's head remains as level as possible, as specified in S16.3.2.1.9 and S16.3.2.1.10 and S16.3.3.1.9 and S16.3.3.1.10.

S16.3.5.4 Remove all slack from the ~~lap-belt-pelvic restraint~~. Pull the upper torso restraint webbing out of the retractor and allow it to retract; repeat this operation four times. Apply a 9 N (2 lbf) to 18 N (4 lbf) tension load to the ~~lap-belt-pelvic restraint~~. If the seat belt assembly ~~belt system~~ is equipped with a tension-relieving device, introduce the maximum amount of

slack into the upper torso ~~restraint belt~~ that is recommended by the manufacturer. If the ~~seat belt assembly belt system~~ is not equipped with a tension-relieving device, allow the excess webbing in the ~~upper torso restraint shoulder belt~~ to be retracted by the retractive force of the retractor.

S17. Offset frontal deformable barrier requirements using 5th percentile adult test dummies

Each vehicle that ~~conforms~~ ~~is certified as complying~~ with S14 shall, at each front outboard designated seating position, meet the injury criteria specified in S15.3 of this ~~TSD standard~~ when the vehicle is crash tested in accordance with the procedures specified in S18 of this ~~TSD standard~~ with the anthropomorphic test devices restrained by a Type 2 seat belt assembly.

S18. Test procedure for offset frontal deformable barrier requirements using 5th percentile adult female dummies

S18.1 General provisions

Place a 49 CFR Part 572 Subpart O 5th percentile adult female test dummy at each front outboard designated seating position of a vehicle, in accordance with the procedures specified in S16.3 of this ~~TSD standard~~. Impact the vehicle traveling longitudinally forward at any speed, up to and including 40 km/h (25 mph), into a fixed offset deformable barrier under the conditions and procedures specified in S18.2 of this ~~TSD standard~~, impacting only the left side of the vehicle.

S18.2 Test conditions

S18.2.1 *Offset frontal deformable barrier.* The offset frontal deformable barrier shall conform to the specifications set forth in Chapter V, Title 49, part 587 Subpart C of the Code of Federal Regulations. ~~of part 587 of this chapter.~~

S18.2.2 *General test conditions.* All of the test conditions specified in S16.2 of this ~~TSD standard~~ apply.

S18.2.3 *Dummy seating procedures.* Position the anthropomorphic test dummies-as specified in S16.3 of this ~~TSD standard~~.

S18.2.4 *Impact configuration.* The test vehicle shall impact the barrier with the longitudinal centerline of the vehicle parallel to the line of travel and perpendicular to the barrier face within a tolerance of ± 5 degrees. The test vehicle shall be aligned so that the vehicle strikes the barrier with 40 percent overlap on the left side of the vehicle, with the vehicle's front engaging the barrier face such that the vehicle's longitudinal centerline is offset outboard of the edge of the barrier face by 10 percent of the vehicle's width ± 50 mm (2.0 in) as illustrated in Figure 10. The vehicle width is defined as the maximum dimension measured across the widest part of the vehicle, including bumpers and molding but excluding such components as exterior mirrors, flexible mud flaps, marker lamps, and dual rear wheel configurations.

S19. Requirements to provide protection for infants in rear facing and convertible child restraints and car beds

S19.1 Each vehicle ~~that conforms~~ certified as complying with S14 shall, at the option of the manufacturer, meet the requirements specified in S19.2 or S19.3, under the test procedures specified in S20.

S19.2 *Option 1—Automatic suppression feature.* Each vehicle shall meet the requirements specified in S19.2.1 through S19.2.3.

S19.2.1 The vehicle shall be equipped with an automatic suppression feature for the passenger air bag which results in deactivation of the air bag during each of the static tests specified in S20.2 (using the 49 CFR part 572 Subpart R 12-month-old CRABI child dummy in any of the child restraints systems identified in sections B and C of appendix A or A–1 of this TSD standard, as appropriate and the 49 CFR part 572 subpart K Newborn Infant dummy in any of the car beds identified in section A of appendix A or A–1, as appropriate), and activation of the air bag system during each of the static tests specified in S20.3 (using the 49 CFR part 572 Subpart O 5th percentile adult female dummy).

S19.2.2 The vehicle shall be equipped with at least one tell-tale which emits light whenever the passenger air bag system is deactivated and does not emit light whenever the passenger air bag system is activated, except that the tell-tale(s) need not illuminate when the passenger seat is unoccupied. ~~Each telltale:~~

- ~~(a) Shall emit yellow light;~~
- ~~(b) Shall have the identifying words “PASSENGER AIR BAG OFF” or “PASS AIR BAG OFF” on the telltale or within 25 mm (1.0 in) of the telltale; and~~
- ~~(c) Shall not be combined with the readiness indicator required by S4.5.2 of this standard.~~
- ~~(d) Shall be located within the interior of the vehicle and forward of and above the design H-point of both the driver's and the right front passenger's seat in their forwardmost seating positions and shall not be located on or adjacent to a surface that can be used for temporary or permanent storage of objects that could obscure the telltale from either the driver's or right front passenger's view, or located where the telltale would be obscured from the driver's view if a rear-facing child restraint listed in appendix A or A–1, as appropriate, is installed in the right front passenger's seat.~~
- ~~(e) Shall be visible and recognizable to a driver and right front passenger during night and day when the occupants have adapted to the ambient light roadway conditions.~~
- ~~(f) Telltales need not be visible or recognizable when not activated.~~
- ~~(g) Means shall be provided for making telltales visible and recognizable to the driver and right front passenger under all driving conditions. The means for providing the required visibility may be adjustable manually or automatically, except that the~~

~~telltale may not be adjustable under any driving conditions to a level that they become invisible or not recognizable to the driver and right front passenger.~~

- ~~(h) The telltale must not emit light except when the passenger air bag is turned off or during a bulb check upon vehicle starting.~~

S19.2.3 The vehicle shall be equipped with a mechanism that indicates whether the air bag system is suppressed, regardless of whether the passenger seat is occupied. The mechanism need not be located in the occupant compartment unless it is the tell-tale described in S19.2.2.

S19.3 *Option 2—Low risk deployment.* Each vehicle shall meet the injury criteria specified in S19.4 of this TSD standard when the passenger air bag is deployed in accordance with the procedures specified in S20.4.

S19.4 *Injury criteria for the 49 CFR part 572, Subpart R 12-month-old CRABI test dummy.*

S19.4.1 All portions of the test dummy and child restraint shall be contained within the outer surfaces of the vehicle passenger occupant compartment.

S19.4.2 Head injury criteria.

- (a) For any two points in time, t_1 and t_2 , during the event which are separated by not more than a 15 millisecond time interval and where t_1 is less than t_2 , the head injury criterion (HIC_{15}) shall be determined using the resultant head acceleration at the center of gravity of the dummy head, a_r , expressed as a multiple of g (the acceleration of gravity) and shall be calculated using the expression:

$$\left[\frac{1}{(t_2 - t_1)} \int_{t_1}^{t_2} a_r dt \right]^{2.5} (t_2 - t_1)$$

- (b) The maximum calculated HIC_{15} value shall not exceed 390.

S19.4.3 The resultant acceleration calculated from the output of the thoracic instrumentation shall not exceed 50 g's, except for intervals whose cumulative duration is not more than 3 milliseconds.

S19.4.4 *Neck injury.* When measuring neck injury, each of the following injury criteria shall be met.

- (a) N_{ij} .

- (1) The shear force (F_x), axial force (F_z), and bending moment (M_y) shall be measured by the dummy upper neck load cell for the duration of the crash event as specified in S4.11. Shear force, axial force, and bending moment shall be filtered for N_{ij} purposes at SAE Recommended Practice J211/1 MAR95 (~~incorporated by reference~~, see the list at 49 CFR Part §571.5 paragraph (k) for the full citation) Channel Frequency Class 600.

- (2) During the event, the axial force (F_z) can be either in tension or compression while the occipital condyle bending moment (M_{ocy}) can be in either flexion or extension. This results in four possible loading conditions for N_{ij} : tension-extension (N_{te}), tension-flexion (N_{tf}), compression-extension (N_{ce}), or compression-flexion (N_{cf}).
- (3) When calculating N_{ij} using equation S19.4.4(a)(4), the critical values, F_{zc} and M_{yc} , are:
- (i) $F_{zc} = 1460 \text{ N (328 lbf)}$ when F_z is in tension
 - (ii) $F_{zc} = 1460 \text{ N (328 lbf)}$ when F_z is in compression
 - (iii) $M_{yc} = 43 \text{ Nm (32 lbf-ft)}$ when a flexion moment exists at the occipital condyle
 - (iv) $M_{yc} = 17 \text{ Nm (13 lbf-ft)}$ when an extension moment exists at the occipital condyle.
- (4) At each point in time, only one of the four loading conditions occurs and the N_{ij} value corresponding to that loading condition is computed and the three remaining loading modes shall be considered a value of zero. The expression for calculating each N_{ij} loading condition is given by:
- $$N_{ij} = (F_z / F_{zc}) + (M_{ocy} / M_{yc})$$
- (5) None of the four N_{ij} values shall exceed 1.0 at any time during the event.
- (b) *Peak tension.* Tension force (F_z), measured at the upper neck load cell, shall not exceed 780 N (175 lbf) at any time.
- (c) *Peak compression.* Compression force (F_z), measured at the upper neck load cell, shall not exceed 960 N (216 lbf) at any time.

S19.4.5 Unless otherwise indicated, instrumentation for data acquisition, data channel frequency class, and moment calculations are the same as given for the 49 CFR part 572 Subpart R 12-month-old CRABI test dummy.

S20. Test procedure for S19

S20.1 General provisions

S20.1.1 Tests specifying the use of a car bed, a rear facing child restraint, or a convertible child restraint may be conducted using any such restraint listed in sections A, B, and C, respectively, of appendix A or A-1 of this TSD standard, as appropriate. The car bed, rear facing child restraint, or convertible child restraint may be unused or have been previously used only for automatic suppression tests. If it has been used, there shall not be any visible damage prior to the test.

S20.1.2 Unless otherwise specified, each vehicle ~~certified conforming~~ to this option shall comply in tests conducted with the right front outboard ~~passenger~~ designated seating

position, if adjustable fore and aft, at full rearward, middle, and full forward positions. If the child restraint or dummy contacts the vehicle interior, move the seat rearward to the next detent that provides clearance, or if the seat is a power seat, using only the control that primarily moves the seat fore and aft, move the seat rearward while assuring that there is a maximum of 5 mm (0.2 in) clearance between the dummy or child restraint and the vehicle interior.

S20.1.3 If the car bed, rear facing child restraint, or convertible child restraint is equipped with a handle, the vehicle shall comply in tests conducted with the handle at both the child restraint manufacturer's recommended position for use in vehicles and in the upright position.

S20.1.4 If the car bed, rear facing child restraint, or convertible child restraint is equipped with a sunshield, the vehicle shall comply in tests conducted with the sunshield both fully open and fully closed.

S20.1.5 The vehicle shall comply in tests with the car bed, rear facing child restraint, or convertible child restraint uncovered and in tests with a towel or blanket weighing up to 1.0 kg (2.2 lb) placed on or over the restraint in any of the following positions:

- (a) with the blanket covering the top and sides of the restraint, and
- (b) with the blanket placed from the top of the vehicle's seat back to the forwardmost edge of the restraint.

S20.1.6 Except as otherwise specified, if the car bed, rear facing child restraint, or convertible child restraint has ~~an anchorage~~ a lower connector system as specified in ~~S5.9 of FMVSS No. 213~~ and is tested in a vehicle with a right front outboard passenger designated seating position vehicle seat that has ~~an a lower universal anchorage system as specified in FMVSS No. 225~~, the vehicle shall comply in the belted tests with the ~~restraint anchorage~~ lower connector system attached to the vehicle ~~seat~~ lower universal anchorage system and the vehicle seat belt assembly unattached. It shall also comply in the belted test requirements with the lower connector ~~restraint anchorage~~ system unattached to the vehicle ~~seat~~ lower universal anchorage system and the vehicle seat belt assembly attached. The vehicle shall comply in the unbelted tests with the ~~restraint anchorage~~ lower connector system unattached to the vehicle ~~seat~~ lower universal anchorage system.

S20.1.7 If the car bed, rear facing child restraint, or convertible child restraint comes equipped with a detachable base, the vehicle shall comply in tests conducted with the detachable base attached to the child restraint and with the detachable base unattached to the child restraint.

S20.1.8 Do not attach any tether straps.

S20.1.9 *Seat set-up.* Unless otherwise stated.

S20.1.9.1 *Lumbar support adjustment.* Position adjustable lumbar supports so that the lumbar support is in its lowest, retracted or deflated adjustment position.

S20.1.9.2 *Other seat adjustments.* Position any adjustable parts of the seat that provide additional support so that they are in the lowest or most open adjustment position.

S20.1.9.3 Set the seat and seat cushion in the position determined in S16.2.10.3.1.

S20.1.9.4 Using only the control that primarily moves the seat in the fore and aft direction, determine the full rearward, middle, and full forward positions of the SCRP. Using any part of any seat or seat cushion adjustments, other than that which primarily moves the seat or seat cushion fore-aft, determine the SCRP mid-point height for each of the three fore-aft test positions, while maintaining, as closely as possible, the seat cushion reference line middle angle determined in S16.2.10.3.1.

S20.1.9.5 The seat back angle, if adjustable, is set at the manufacturer's nominal design seat back angle for a 50th percentile adult male as specified in S8.1.3.

S20.1.9.6 If adjustable, set the head restraint at the full down and full forward position.

S20.1.10 The longitudinal centerline of a bucket seat cushion is defined by a vertical plane that passes through the SgRP and is parallel to the longitudinal centerline of the vehicle.

S20.2 *Static tests of automatic suppression feature which shall result in deactivation of the passenger air bag.* Each vehicle that conforms ~~certified as complying~~ with S19.2 shall meet the following test requirements.

S20.2.1 *Belted rear facing and convertible child restraints systems.*

S20.2.1.1 The vehicle shall comply in tests using any child restraint specified in section B and section C of appendix A or A-1 of this TSD standard, as appropriate, installed in the right front outboard passenger designated seating position vehicle seat in the following orientations:

- (a) With the section B and section C child restraints facing rearward as appropriate; and
- (b) With the section C child restraints facing forward.

S20.2.1.2 The vehicle shall comply with the child restraint attached to the vehicle in the following manner:

- (a) Using the vehicle seat belt assembly safety belts as specified in S20.2.1.5; and
- (b) If ~~the child restraint is certified to S5.9 of §571.213, and~~ the vehicle seat has an lower universal anchorage system ~~as specified in §571.225,~~ using only the mechanism provided by the child restraint manufacturer for attachment to the lower universal anchorages system as specified in S20.2.1.6.

S20.2.1.3 Locate a vertical plane through the longitudinal centerline of the child restraint. This will be referred to as “Plane A.”

S20.2.1.4 For bucket seats, “Plane B” refers to a vertical plane parallel to the vehicle longitudinal centerline through the longitudinal centerline of the right front outboard passenger designated seating position vehicle seat cushion. For bench seats, “Plane B” refers to a vertical plane through the right front outboard passenger designated seating position vehicle seat parallel to the vehicle longitudinal centerline the same distance from the longitudinal centerline of the vehicle as the center of the steering wheel.

S20.2.1.5 *Installation with vehicle seat belt assemblies ~~safety belts~~.*

- (a) Place any adjustable seat belt assembly anchorages at the vehicle manufacturer's nominal design position for a 50th percentile adult male occupant.
- (b) Without attaching the child restraint lower connector system ~~anchorage system~~ ~~components specified in S5.9 of §571.213~~ to a vehicle child restraint lower universal anchorage system §571.225, align the child restraint system facing rearward or forward, depending on the orientation being tested, such that Plane A is aligned with Plane B.
- (c) While maintaining the child restraint positions achieved in S20.2.1.5(b), secure the child restraint by following, to the extent possible, the child restraint manufacturer's directions regarding proper installation of the restraint for the orientation being tested. Cinch the vehicle belts to any tension from zero up to 134 N to secure the child restraint. Measure belt tension in a flat, straight section of the lap belt pelvic restraint ~~lap belt pelvic restraint~~ between the child restraint belt path and the contact point with the belt anchor or vehicle seat, on the side away from the buckle (to avoid interference from the shoulder portion of the belt).
- (d) Position the 49 CFR part 572 subpart R 12-month-old CRABI dummy in the child restraint by following, to the extent possible, the manufacturer's instructions provided with the child restraint for seating infants.
- (e) Start the vehicle engine or place the ignition switch in the “on” position, whichever will turn on the suppression system, and close all vehicle doors. Wait 10 seconds, then check whether the air bag is deactivated.

S20.2.1.6 *Installation using the lower universal anchorage system ~~anchor bars~~ and the child restraint manufacturer provided attachment mechanism.*

S20.2.1.6.1 If the attachment mechanism provided by the manufacturer incorporates a strap(s), use the following procedure:

- (a) Place the child restraint on the vehicle seat facing rearward or forward, depending on the orientation being tested, with Plane A of the child restraint aligned within ± 10 mm with a longitudinal vertical plane passing through a point midway between the centers of the two lower universal anchorage system ~~anchor bars~~.
- (b) Position any adjustments on the child restraint, to the extent possible according to the child restraint manufacturer's instructions.
- (c) Connect the lower connector system ~~anchor straps~~ of the restraint to the lower universal anchorage system ~~anchor bars~~ of the seat and remove the slack, but do not apply any load using these straps.
- (d) Move the child restraint rearward until it contacts the seat back.
- (e) Use the loading device equipped with the loading foot shown in Figure A1 and position it as shown in Figure A2 of appendix A and appendix A-1 of this section.

- The 15 ± 3 degree angle of the loading device illustrated in Figure A2 is determined with an initial preload of 75 ± 25 N.
- (f) Over a period of 90 ± 30 seconds, increase the load to $875\text{N}\pm 25$ N.
 - (g) After achieving the 875 N load in step (f) of this section, hold the bar length at present position and allow the load to settle for 60 seconds.
 - (h) Following the one-minute settling period specified in step (g) of this section, increase the load to 875 ± 25 N such that the 875 ± 25 N load is achieved within 10 seconds of the settling period.
 - (i) Hold the bar length at present position and allow the load to settle for 120 seconds after achieving the load in step (f) of this section.
 - (j) Following the settling period specified in step (i) of this section, increase the load to 875 ± 25 N such that the 875 ± 25 N load is achieved within 10 seconds of the settling period.
 - (k) Observe the settling of the load and tighten the lower connector system anchor straps when the load is 850 ± 5 N or 180 seconds has elapsed since achieving the 875 ± 25 N load in step (f) of this section, whichever comes first. Tighten the lower connector system anchor straps at the same time such that the load is reduced 15 ± 10 N and the change occurs within 2 seconds.
 - (l) Remove the loading device and position the 49 CFR part 572 subpart R 12-month-old CRABI dummy in the child restraint by following, to the extent possible, the manufacturer's instructions provided with the child restraint for seating infants.
 - (m) Start the vehicle engine or place the ignition switch in the "on" position, whichever will turn on the suppression system, and close all vehicle doors. Wait 10 seconds, then check whether the air bag is deactivated.

S20.2.1.6.2 If the mechanism provided by the manufacturer does not incorporate a strap(s), use the following procedure:

- (a) Place the vehicle seat in the rearmost and mid-height position.
- (b) Place the child restraint on the vehicle seat facing rearward or forward, depending on the orientation being tested, with Plane A of the child restraint aligned within ± 10 mm with a longitudinal vertical plane passing through a point midway between the centers of the two lower universal anchorage system anchor bars.
- (c) Position any adjustments on the child restraint, to the extent possible, according to the child restraint manufacturer's instructions.
- (d) Connect the lower anchor attachments to the lower universal anchorage system anchor bars following, to the extent possible, the child restraint manufacturer's instructions.
- (e) Move the child restraint rearward until it contacts the seat back.

- (f) If the child restraint does not use a linear sliding or ratcheting mechanism that requires the application of force to securely install the child restraint, follow, to the extent possible, the CRS manufacturer's instructions for installing the child restraint onto the seat. Do not load the seat as provided in S20.2.1.6.2(g).
- (g) If the child restraint uses a linear sliding or ratcheting mechanism that requires the application of force to securely install the child restraint, within 25 ± 5 seconds, apply a 475 ± 25 N force, that has no lateral component, aligned angularly ± 10 degrees with a parallel plane located within ± 100 mm of the plane formed by the linear mechanism. Release the force.
- (h) Position the 49 CFR part 572 subpart R 12-month-old CRABI dummy in the child restraint by following, to the extent possible, the manufacturer's instructions provided with the child restraint for seating infants.
- (i) Move the vehicle seat to the seat position being tested (full rear, mid, full forward).
- (j) Start the vehicle engine or place the ignition switch in the "on" position, whichever will turn on the suppression system, and close all vehicle doors. Wait 10 seconds, then check whether the air bag is deactivated.

S20.2.2 *Unbelted rear facing and convertible child restraints.*

S20.2.2.1 The vehicle shall comply in tests using any child restraint specified in section B and section C of appendix A or A-1 of this TSD standard, as appropriate.

S20.2.2.2 Locate a vertical plane through the longitudinal centerline of the child restraint. This will be referred to as "Plane A".

S20.2.2.3 For bucket seats, "Plane B" refers to a vertical plane parallel to the vehicle longitudinal centerline through the longitudinal centerline of the right front outboard passenger designated seating position vehicle seat cushion. For bench seats, "Plane B" refers to a vertical plane through the right front outboard passenger designated seating position seat parallel to the vehicle longitudinal centerline the same distance from the longitudinal centerline of the vehicle as the center of the steering wheel.

S20.2.2.4 *Facing rear.*

- (a) Align the child restraint system facing rearward such that Plane A is aligned with Plane B and the child restraint is in contact with the seat back.
- (b) Position the 49 CFR part 572 subpart R 12-month-old CRABI dummy in the child restraint by following, to the extent possible, the manufacturer's instructions provided with the child restraint for seating infants.
- (c) Start the vehicle engine or place the ignition switch in the "on" position, whichever will turn on the suppression system, and close all vehicle doors. Wait 10 seconds, then check whether the air bag is deactivated.

S20.2.2.5 *Facing forward.*

- (a) Align the child restraint system facing forward such that Plane A is aligned with Plane B and the child restraint is in contact with the seat back.
- (b) Position the 49 CFR part 572 subpart R 12-month-old CRABI dummy in the child restraint by following, to the extent possible, the manufacturer's instructions provided with the child restraint for seating infants.
- (c) Start the vehicle engine or place the ignition switch in the “on” position, whichever will turn on the suppression system, and close all vehicle doors. Wait 10 seconds, then check whether the air bag is deactivated.

S20.2.3 *Tests with a belted car bed.*

S20.2.3.1 The vehicle shall comply in tests using any car bed specified in section A of appendix A or A-1 of this TSD standard, as appropriate.

S20.2.3.2

- (a) Install the car bed following, to the extent possible, the car bed manufacturer's directions regarding proper installation of the car bed. If the seat belt assembly cannot be secured around the car bed, move the seat rearward to the next detent that allows the belt to be secured around the car bed, or if the seat is a power seat, using only the control that primarily moves the seat fore and aft, move the seat rearward the minimum distance necessary for the seat belt assembly to be secured around the car bed.
- (b) Place any adjustable seat belt assembly anchorages at the vehicle manufacturer's nominal design position for a 50th percentile adult male occupant. Cinch the vehicle belts to secure the car bed.
- (c) Position the 49 CFR part 572 subpart K Newborn Infant dummy in the car bed by following, to the extent possible, the car bed manufacturer's instructions provided with the car bed for positioning infants.
- (d) Start the vehicle engine or place the ignition switch in the “on” position, whichever will turn on the suppression system, and close all vehicle doors. Wait 10 seconds, then check whether the air bag is deactivated.

S20.3 Static tests of automatic suppression feature which shall result in activation of the passenger air bag system

S20.3.1 Each vehicle ~~certified~~ that conforms to this option shall comply in tests conducted with the right front outboard ~~passenger~~ designated seating position, if adjustable fore and aft, at the mid-height, in the full rearward and middle positions determined in S20.1.9.4, and the forward position determined in S16.3.3.1.8.

S20.3.2 Place a 49 CFR part 572 subpart O 5th percentile adult female test dummy at the right front outboard ~~passenger~~ designated seating position of the vehicle, in accordance with

procedures specified in S16.3.3 of this TSD standard, except as specified in S20.3.1, subject to the fore-aft seat positions in S20.3.1. Do not fasten the seat belt assembly.

S20.3.3 Start the vehicle engine or place the ignition switch in the “on” position, whichever will turn on the suppression system, and then close all vehicle doors.

S20.3.4 Wait 10 seconds, then check whether the air bag system is activated.

S20.4 Low risk deployment test

Each vehicle that is conforms certified as complying with S19.3 shall meet the following test requirements.

S20.4.1 Position the right front outboard ~~passenger~~ designated seating position vehicle seat at the mid-height in the full forward position determined in S20.1.9.4, and adjust the seat back (if adjustable independent of the seat) to the nominal design position for a 50th percentile adult male as specified in S8.1.3. Position adjustable lumbar supports so that the lumbar support is in its lowest, retracted or deflated adjustment position. Position any adjustable parts of the seat that provide additional support so that they are in the lowest or most open adjustment position. If adjustable, set the head restraint at the full down and most forward position. If the child restraint or dummy contacts the vehicle interior, do the following: using only the control that primarily moves the seat in the fore and aft direction, move the seat rearward to the next detent that provides clearance; or if the seat is a power seat, move the seat rearward while assuring that there is a maximum of 5 mm (0.2 in) clearance.

S20.4.2 The vehicle shall comply in tests using any child restraint specified in section B and section C of appendix A or A-1 of this TSD standard, as appropriate.

S20.4.3 Locate a vertical plane through the longitudinal centerline of the child restraint. This will be referred to as “Plane A”.

S20.4.4 For bucket seats, “Plane B” refers to a vertical plane parallel to the vehicle longitudinal centerline through the longitudinal centerline of the right front outboard ~~passenger~~ designated seating position seat cushion. For bench seats, “Plane B” refers to a vertical plane through the right front outboard ~~passenger~~ designated seating position seat parallel to the vehicle longitudinal centerline that is the same distance from the longitudinal centerline of the vehicle as the center of the steering wheel.

S20.4.5 Align the child restraint system facing rearward such that Plane A is aligned with Plane B.

S20.4.6 If ~~the child restraint is certified to S5.9 of §571.213, and~~ the vehicle seat has an lower universal anchorage system as specified in §571.225, attach the child restraint to the vehicle ~~seat~~ lower universal anchorage as specified in S20.2.1.6. Do not attach the top tether strap of the child restraint system. Do not attach the vehicle seat belt assembly ~~safety belt~~.

S20.4.7 While maintaining the child restraint position achieved in S20.4.5, secure the child restraint by following, to the extent possible, the child restraint manufacturer's directions regarding proper installation of the restraint in the rear facing mode. Place any adjustable seat belt assembly anchorages at the manufacturer's nominal design position for a 50th percentile

adult male occupant. Cinch the vehicle belts to any tension from zero up to 134 N (30 lb) to secure the child restraint. Measure belt tension in a flat, straight section of the ~~lap belt pelvic restraint~~ between the child restraint belt path and the contact point with the belt anchor or vehicle seat, on the side away from the buckle (to avoid interference from the shoulder portion of the belt).

S20.4.8 Position the 49 CFR part 572 subpart R 12-month-old CRABI dummy in the child restraint by following, to the extent possible, the manufacturer's instructions provided with the child restraint for seating infants.

S20.4.9 Deploy the right front outboard ~~passenger~~ designated seating position frontal air bag system. If the air bag system contains a multistage inflator, the vehicle shall be able to comply at any stage or combination of stages or time delay between successive stages that could occur in the presence of an infant in a rear facing child restraint and a 49 CFR part 572, subpart R 12-month-old CRABI dummy positioned according to S20.4, and also with the seat at the mid-height, in the middle and full rearward positions determined in S20.1.9.4, in a fixed collision ~~rigid~~ barrier crash test at speeds up to 64 km/h (40 mph).

S21. Requirements using 3-year-old child dummies

S21.1 Each vehicle that ~~is~~ conforms ~~certified as complying~~ with S14 shall, at the option of the manufacturer, meet the requirements specified in S21.2, S21.3, S21.4 or S21.5, under the test procedures specified in S22 or S28, as applicable.

S21.2 *Option 1—Automatic suppression feature.* Each vehicle shall meet the requirements specified in S21.2.1 through S21.2.3.

S21.2.1 The vehicle shall be equipped with an automatic suppression feature for the passenger air bag which results in deactivation of the air bag during each of the static tests specified in S22.2 (using the 49 CFR part 572 subpart P 3-year-old child dummy and, as applicable, any child restraint specified in section C and section D of appendix A or A-1 of this TSD standard, as appropriate), and activation of the air bag system during each of the static tests specified in S22.3 (using the 49 CFR part 572 subpart O 5th percentile adult female dummy).

S21.2.2 The vehicle shall be equipped with a tell-tale light meeting the requirements specified in S19.2.2.

S21.2.3 The vehicle shall be equipped with a mechanism that indicates whether the air bag is suppressed, regardless of whether the passenger seat is occupied. The mechanism need not be located in the occupant compartment unless it is the tell-tale described in S21.2.2.

S21.3 *Option 2—Dynamic automatic suppression system that suppresses the air bag when an occupant is out of position.* (This option is available under the conditions set forth in S27.1.) The vehicle shall be equipped with a dynamic automatic suppression system for the passenger air bag system which meets the requirements specified in S27.

S21.4 *Option 3—Low risk deployment.* Each vehicle shall meet the injury criteria specified in S21.5 of this TSD standard when the passenger air bag is deployed in accordance with both of the low risk deployment test procedures specified in S22.4.

S21.5 *Injury criteria for the 49 CFR part 572, subpart P 3-year-old child test dummy.*

S21.5.1 All portions of the test dummy shall be contained within the outer surfaces of the vehicle ~~passenger~~ occupant compartment.

S21.5.2 *Head injury criteria.*

- (a) For any two points in time, t_1 and t_2 , during the event which are separated by not more than a 15 millisecond time interval and where t_1 is less than t_2 , the head injury criterion (HIC_{15}) shall be determined using the resultant head acceleration at the center of gravity of the dummy head, a_r , expressed as a multiple of g (the acceleration of gravity) and shall be calculated using the expression:

$$\left[\frac{1}{(t_2 - t_1)} \int_{t_1}^{t_2} a_r dt \right]^{2.5} (t_2 - t_1)$$

- (b) The maximum calculated HIC_{15} value shall not exceed 570.

S21.5.3 The resultant acceleration calculated from the output of the thoracic instrumentation shall not exceed 55 g 's, except for intervals whose cumulative duration is not more than 3 milliseconds.

S21.5.4 Compression deflection of the sternum relative to the spine, as determined by instrumentation, shall not exceed 34 millimeters (1.3 in).

S21.5.5 *Neck injury.* When measuring neck injury, each of the following injury criteria shall be met.

- (a) *Nij.*
- (1) The shear force (F_x), axial force (F_z), and bending moment (M_y) shall be measured by the dummy upper neck load cell for the duration of the crash event as specified in S4.11. Shear force, axial force, and bending moment shall be filtered for Nij purposes at SAE Recommended Practice J211/1 MAR95 (~~incorporated by reference, see the list at 49 CFR Part §571.5 paragraph (k) for the full citation~~) Channel Frequency Class 600.
 - (2) During the event, the axial force (F_z) can be either in tension or compression while the occipital condyle bending moment (M_{oc}) can be in either flexion or extension. This results in four possible loading conditions for Nij : Tension-extension (N_{te}), tension-flexion (N_{tf}), compression-extension (N_{ce}), or compression-flexion (N_{cf}).
 - (3) When calculating Nij using equation S21.5.5(a)(4), the critical values, F_{zc} and M_{yc} , are:

- (i) $F_{zc} = 2120 \text{ N}$ (477 lbf) when F_z is in tension
- (ii) $F_{zc} = 2120 \text{ N}$ (477 lbf) when F_z is in compression
- (iii) $M_{yc} = 68 \text{ Nm}$ (50 lbf-ft) when a flexion moment exists at the occipital condyle
- (iv) $M_{yc} = 27 \text{ Nm}$ (20 lbf-ft) when an extension moment exists at the occipital condyle.

- (4) At each point in time, only one of the four loading conditions occurs and the N_{ij} value corresponding to that loading condition is computed and the three remaining loading modes shall be considered a value of zero. The expression for calculating each N_{ij} loading condition is given by:

$$N_{ij} = (F_z / F_{zc}) + (M_{oc} / M_{yc})$$

- (5) None of the four N_{ij} values shall exceed 1.0 at any time during the event.

- (b) *Peak tension.* Tension force (F_z), measured at the upper neck load cell, shall not exceed 1130 N (254 lbf) at any time.
- (c) *Peak compression.* Compression force (F_z), measured at the upper neck load cell, shall not exceed 1380 N (310 lbf) at any time.

S21.5.6 Unless otherwise indicated, instrumentation for data acquisition, data channel frequency class, and moment calculations are the same as given in 49 CFR part 572 subpart P 3-year-old child test dummy.

S22. Test procedure for S21

S22.1 General provisions and definitions

S22.1.1 Tests specifying the use of a forward facing child restraint, including a booster seat where applicable, may be conducted using any such restraint listed in section C and section D of appendix A or A-1 of this TSD standard, as appropriate. The child restraint may be unused or have been previously used only for automatic suppression tests. If it has been used, there shall not be any visible damage prior to the test. Booster seats are to be used in the manner appropriate for a 3-year-old child of the same height and weight as the 3-year-old child dummy.

S22.1.2 Unless otherwise specified, each vehicle ~~certified~~ that conforms to this option shall comply in tests conducted with the right front outboard ~~passenger designated~~ seating position at the mid-height, in the full rearward, middle, and the full forward positions determined in S22.1.7.4. If the dummy contacts the vehicle interior, using only the control that primarily moves the seat fore and aft, move the seat rearward to the next detent that provides clearance. If the seat is a power seat, move the seat rearward while assuring that there is a maximum of 5 mm (0.2 in) clearance.

S22.1.3 Except as otherwise specified, if the child restraint has an ~~anchorage~~ lower connector system as specified in S5.9 of FMVSS No. 213 and is tested in a vehicle with a right front outboard passenger designated seating position vehicle seat that has an a lower universal anchorage system as specified in FMVSS No. 225, the vehicle shall comply with the belted test conditions with the ~~restraint anchorage~~ lower connector system attached to the vehicle seat lower universal anchorage system and the vehicle seat belt assembly unattached. It shall also comply with the belted test conditions with the ~~restraint anchorage~~ lower connector system unattached to the vehicle seat lower universal anchorage system and the vehicle seat belt assembly attached.

S22.1.4 Do not attach any tether straps.

S22.1.5 The definitions provided in S16.3.1 through S16.3.10 apply to the tests specified in S22.

S22.1.6 For leg and thigh angles use the following references:

- (a) *Thigh* —a straight line on the thigh skin between the center of the 5/16×1/2 in. screw (part 9001024, item 10 in drawing 210–0000 sheet 2 of 7, complete assembly (HYB III 3 YR OLD)) and the knee bolt (part 210–5301 in drawing 210–5000–1 & –1, leg assembly).
- (b) *Leg* —a straight line on the leg skin between the center of the ankle bolt (part 210–5701 in drawing 210–5000–1 & –2, leg assembly) and the knee bolt (part 210–5301 in drawing 210–5000–1 & –2, leg assembly).

S22.1.7 *Seat set-up*. Unless otherwise stated,

S22.1.7.1 *Lumbar support adjustment*. Position adjustable lumbar supports so that the lumbar support is in its lowest, retracted or deflated adjustment position.

S22.1.7.2 *Other seat adjustments*. Position any adjustable parts of the seat that provide additional support so that they are in the lowest or most open adjustment position.

S22.1.7.3 Set the seat and seat cushion in the position determined in S16.2.10.3.1.

S22.1.7.4 Using only the control that primarily moves the seat in the fore and aft direction, determine the full rearward, middle, and full forward positions of the SCRP. Using any part of any seat or seat cushion adjustments other than that which primarily moves the seat or seat cushion fore-aft, determine the SCRP mid-point height for each of the three fore-aft test positions, while maintaining, as closely as possible, the seat cushion reference line angle determined in S16.2.10.3.1.

S22.1.7.5 The seat back angle, if adjustable, is set at the manufacturer's nominal design seat back angle for a 50th percentile adult male as specified in S8.1.3.

S22.1.7.6 If adjustable, set the head restraint at the full down and full forward position.

S22.2 *Static tests of automatic suppression feature which shall result in deactivation of the passenger air bag*. Each vehicle that is conforms ~~certified as complying~~ with S21.2 shall meet the following test requirements:

22.2.1 *Belted test with forward facing child restraint or booster seat ~~child restraint~~*

S22.2.1.1 Install the restraint in the right front outboard ~~passenger~~ designated seating position ~~vehicle seat~~ in accordance, to the extent possible, with the child restraint manufacturer's instructions provided with the seat for use by children with the same height and weight as the 3-year-old child dummy.

S22.2.1.2 Locate a vertical plane through the longitudinal centerline of the child restraint. This will be referred to as "Plane A".

S22.2.1.3 For bucket seats, "Plane B" refers to a vertical longitudinal plane through the longitudinal centerline of the seat cushion of the right front outboard ~~passenger~~ designated seating position ~~vehicle seat~~. For bench seats, "Plane B" refers to a vertical plane through the right front outboard ~~passenger~~ designated seating position ~~vehicle seat~~ parallel to the vehicle longitudinal centerline the same distance from the longitudinal centerline of the vehicle as the center of the steering wheel.

S22.2.1.4 The vehicle shall comply with the child restraint belted to the vehicle in the following manner:

- (a) Using the vehicle seat belt assemblies ~~safety belts~~ as specified in S22.2.1.5 with section C and section D child restraints of appendix A or A-1, as appropriate, of this TSD section ~~section~~ designed to be secured to the vehicle seat even when empty; and
- (b) If ~~the child restraint is certified to S5.9 of §571.213, and~~ the vehicle seat has an lower universal anchorage system ~~as specified in §571.225~~, using only the mechanism provided by the child restraint manufacturer for attachment to the lower universal anchorage system as specified in S22.2.1.6.

S22.2.1.5 *Installation with vehicle seat belt assemblies ~~safety belts~~.*

- (a) Place any adjustable seat belt assembly ~~safety belt~~ anchorages at the vehicle manufacturer's nominal design position for a 50th percentile adult male occupant.
- (b) Without attaching the child restraint lower connector anchorage system components ~~specified in S5.9 of §571.213~~ to a vehicle ~~child restraint~~ lower universal anchorage system ~~specified in in §571.225~~, align the child restraint system facing forward, such that Plane A is aligned with Plane B.
- (c) While maintaining the child restraint positions achieved in S22.2.1.5(b), secure the child restraint by following, to the extent possible, the child restraint manufacturer's directions regarding proper installation of the restraint. Cinch the vehicle belts to any tension from zero up to 134 N to secure the child restraint. Measure belt tension in a flat, straight section of the ~~lap belt pelvic restraint~~ between the child restraint belt path and the contact point with the belt anchor or vehicle seat, on the side away from the buckle (to avoid interference from the shoulder portion of the belt).

S22.2.1.6 *Installation using the lower universal anchorage system ~~anchor bars~~ and the attachment mechanism provided by the child restraint manufacturer.*

S22.2.1.6.1 If the mechanism provided by the manufacturer incorporates a strap(s), use the following procedure.

- (a) Place the child restraint on the vehicle seat facing forward, with Plane A of the child restraint aligned within ± 10 mm with a longitudinal vertical plane passing through a point midway between the centers of the two lower universal anchorage system ~~anchor~~ bars.
- (b) Position any adjustments on the child restraint, to the extent possible, according to the child restraint manufacturer's instructions.
- (c) Connect the lower connector system ~~anchor straps~~ to the lower universal anchorage system ~~anchor bars~~ and remove most of the slack, but do not apply any load using these straps.
- (d) Move the child restraint rearward until it contacts the seat back.
- (e) Do not attach any top tether straps.
- (f) Use the loading device equipped with the loading foot shown in Figure A1 and position it as shown in Figure A2 of appendix A and appendix A-1 of this TSD standard. The 15 ± 3 degree angle of the loading device is determined with an initial preload of 75 ± 25 N.
- (g) Over a period of 90 ± 30 seconds, increase the load to 875 ± 25 N.
- (h) After achieving the 875 N load in step (g) of this section, hold the bar length at the present position and allow the load to settle for 60 seconds.
- (i) Following the one-minute settling period specified in step (h) of this section, increase the load to 875 ± 25 N such that the 875 ± 25 N load is achieved within 10 seconds of the settling period.
- (j) Hold the bar length at present position and allow the load to settle for 120 seconds after achieving the load in step (g) of this section.
- (k) Following the settling period specified in step (j) of this section, increase the load to 875 ± 25 N such that the 875 ± 25 N load is achieved within 10 seconds of the settling period.
- (l) Observe the settling of the load and tighten the lower connector system ~~anchor straps~~ when the load is 850 ± 5 N or 180 seconds has elapsed since achieving the 875 ± 25 N load in step (g) of this section, whichever comes first. Tighten the lower connector system ~~anchor straps~~ at the same time such that the load is reduced 15 ± 10 N and the change occurs within 2 seconds.
- (m) Remove the loading device.

S22.2.1.6.2 If the mechanism provided by the manufacturer does not incorporate a strap(s), use the following procedure.

- (a) Place the vehicle seat in the rear-most and mid-height position.
- (b) Place the child restraint on the vehicle seat facing forward with Plane A of the child restraint aligned within ± 10 mm with a longitudinal vertical plane passing through a point midway between the centers of the two lower universal anchorage system ~~anchor~~ bars.
- (c) Position any adjustments on the child restraint, to the extent possible, according to the child restraint manufacturer's instructions.
- (d) Connect the lower anchor attachments to the lower ~~anchor~~ universal anchorage system ~~bars~~ following, to the extent possible, the child restraint manufacturer's instructions.
- (e) Move the child restraint rearward until it contacts the seat back.
- (f) Do not attach any top tether straps.
- (g) If the child restraint does not use a linear sliding or ratcheting mechanism that requires the application of force to securely install the child restraint, follow, to the extent possible, the manufacturer's instructions for installing the child restraint onto the seat. Do not load the seat as provided in S22.2.1.6.2(h).
- (h) If the child restraint uses a linear sliding or ratcheting mechanism that requires the application of force to securely install the child restraint, within 25 ± 5 seconds, apply a 475 ± 25 N force, that has no lateral component, aligned angularly ± 10 degrees with a parallel plane located within ± 100 mm of the plane formed by the linear mechanism. Release the force.
- (i) Move the vehicle seat to the seat position being tested (full rear, mid, full forward).

S22.2.1.7 *Forward facing child restraint.*

S22.2.1.7.1 After installation of a forward facing child restraint, position the 49 CFR part 572 subpart P 3-year-old child dummy in the child restraint such that the dummy's lower torso is centered on the child restraint and the dummy's spine is against the seat back of the child restraint. Place the arms at the dummy's sides.

S22.2.1.7.2 Attach all belts that come with the child restraint that are appropriate for a child of the same height and weight as the 3-year-old child dummy, if any, by following, to the extent possible, the manufacturer's instructions provided with the child restraint for seating children.

S22.2.1.7.3 Start the vehicle engine or place the ignition switch in the "on" position, whichever will turn on the suppression system, and close all vehicle doors. Wait 10 seconds, then check whether the air bag is deactivated.

S22.2.1.8 *Booster seat ~~child restraint~~.*

S22.2.1.8.1 After installation of a booster seat ~~child restraint~~, position the 49 CFR part 572 subpart P 3-year-old child dummy in the booster seat such that the dummy's lower torso is centered on the booster seat cushion and the dummy's back is parallel to and in contact with the booster seat back or, if there is no booster seat back, the vehicle seat back. Place the arms at the dummy's-sides.

S22.2.1.8.2 If applicable, attach all belts that come with the booster seat ~~child restraint~~ that are appropriate for a child of the same height and weight as the 3-year-old child dummy, if any, by following, to the extent possible, the manufacturer's instructions provided with the child restraint for seating children.

S22.2.1.8.3 If applicable, place the Type 2 manual seat belt assembly around the test dummy and fasten the latch. Remove all slack from the ~~lap belt pelvic restraint~~ portion. Pull the upper torso restraint webbing out of the retractor and allow it to retract; repeat this four times. Apply a 9 to 18 N (2 to 4 lb) tension load to the ~~lap belt pelvic restraint~~. Allow the excess webbing in the upper torso restraint ~~belt~~ to be retracted by the retractive force of the retractor.

S22.2.1.8.4 Start the vehicle engine or place the ignition switch in the "on" position, whichever will turn on the suppression system, and then close all vehicle doors. Wait 10 seconds, then check whether the air bag is deactivated.

S22.2.2 *Unbelted tests with dummies.* Place the 49 CFR part 572 subpart P 3-year-old child dummy on the right front outboard passenger designated seating position vehicle seat in any of the following positions (without using a child restraint or booster seat or the vehicle's seat belts assemblies):

S22.2.2.1 *Sitting on seat with back against seat back.*

- (a) Place the dummy on the right front outboard passenger designated seating position seat.
- (b) In the case of vehicles equipped with bench seats, position the midsagittal plane of the dummy vertically and parallel to the vehicle's longitudinal centerline and the same distance from the vehicle's longitudinal centerline, within ± 10 mm (± 0.4 in), as the center of the steering wheel. In the case of vehicles equipped with bucket seats, position the midsagittal plane of the dummy vertically such that it coincides with the longitudinal centerline of the seat cushion, within ± 10 mm (± 0.4 in). Position the torso of the dummy against the seat back. Position the dummy's thighs against the seat cushion.
- (c) Allow the legs of the dummy to extend off the surface of the seat.
- (d) Rotate the dummy's upper arms down until they contact the seat back.
- (e) Rotate the dummy's lower arms until the dummy's hands contact the seat cushion.
- (f) Start the vehicle engine or place the ignition switch in the "on" position, whichever will turn on the suppression system, and then close all vehicle doors.
- (g) Wait 10 seconds, then check whether the air bag is deactivated.

S22.2.2.2 *Sitting on seat with back against reclined seat back.* Repeat the test sequence in S22.2.2.1 with the seat back angle 25 degrees rearward of the manufacturer's nominal design position for the 50th percentile adult male. If the seat will not recline 25 degrees rearward of the nominal design position, use the closest position that does not exceed 25 degrees.

S22.2.2.3 *Sitting on seat with back not against seat back.*

- (a) Place the dummy on the right front outboard passenger-designated seating position seat.
- (b) In the case of vehicles equipped with bench seats, position the midsagittal plane of the dummy vertically and parallel to the vehicle's longitudinal centerline and the same distance from the vehicle's longitudinal centerline, within ± 10 mm (± 0.4 in), as the center of the steering wheel. In the case of vehicles equipped with bucket seats, position the midsagittal plane of the dummy vertically such that it coincides with the longitudinal centerline of the seat cushion, within ± 10 mm (± 0.4 in). Position the dummy with the spine vertical so that the horizontal distance from the dummy's back to the seat back is no less than 25 mm (1.0 in) and no more than 150 mm (6.0 in), as measured along the dummy's midsagittal plane at the mid-sternum level. To keep the dummy in position, a material with a maximum breaking strength of 311 N (70 lb) may be used to hold the dummy.
- (c) Position the dummy's thighs against the seat cushion.
- (d) Allow the legs of the dummy to extend off the surface of the seat.
- (e) Position the upper arms parallel to the spine and rotate the dummy's lower arms until the dummy's hands contact the seat cushion.
- (f) Start the vehicle engine or place the ignition switch in the "on" position, whichever will turn on the suppression system, and then close all vehicle doors.
- (g) Wait 10 seconds, then check whether the air bag is deactivated.

S22.2.2.4 *Sitting on seat edge, spine vertical, hands by the dummy's sides.*

- (a) In the case of vehicles equipped with bench seats, position the midsagittal plane of the dummy vertically and parallel to the vehicle's longitudinal centerline and the same distance from the vehicle's longitudinal centerline, within ± 10 mm (± 0.4 in), as the center of the steering wheel. In the case of vehicles equipped with bucket seats, position the midsagittal plane of the dummy vertically such that it coincides with the longitudinal centerline of the seat cushion, within ± 10 mm (± 0.4 in).
- (b) Position the dummy in the seated position forward in the seat such that the legs are vertical and the back of the legs rest against the front of the seat with the spine vertical. If the dummy's feet contact the floor pan, rotate the legs forward until the dummy is resting on the seat with the feet positioned flat on the floor pan and the dummy spine vertical. To keep the dummy in position, a material with a maximum breaking strength of 311 N (70 lb) may be used to hold the dummy.
- (c) Place the upper arms parallel to the spine.

- (d) Lower the dummy's lower arms such that they contact the seat cushion.
- (e) Start the vehicle engine or place the ignition switch in the "on" position, whichever will turn on the suppression system, and then close all vehicle doors.
- (f) Wait 10 seconds, then check whether the air bag is deactivated.

S22.2.2.5 *Standing on seat, facing forward.*

- (a) In the case of vehicles equipped with bench seats, position the midsagittal plane of the dummy vertically and parallel to the vehicle's longitudinal centerline and the same distance from the vehicle's longitudinal centerline, within ± 10 mm (± 0.4 in), as the center of the steering wheel rim. In the case of vehicles equipped with bucket seats, position the midsagittal plane of the dummy vertically such that it coincides with the longitudinal centerline of the seat cushion, within ± 10 mm (± 0.4 in). Position the dummy in a standing position on the right front outboard passenger designated seating position seat cushion facing the front of the vehicle while placing the heels of the dummy's feet in contact with the seat back.
- (b) Rest the dummy against the seat back, with the arms parallel to the spine.
- (c) If the head contacts the vehicle roof, recline the seat so that the head is no longer in contact with the vehicle roof, but allow no more than 5 mm (0.2 in) distance between the head and the roof. If the seat does not sufficiently recline to allow clearance, omit the test.
- (d) If necessary use a material with a maximum breaking strength of 311 N (70 lb) or spacer blocks to keep the dummy in position.
- (e) Start the vehicle engine or place the ignition switch in the "on" position, whichever will turn on the suppression system, and then close all vehicle doors.
- (f) Wait 10 seconds, then check whether the air bag is deactivated.

S22.2.2.6 *Kneeling on seat, facing forward.*

- (a) In the case of vehicles equipped with bench seats, position the midsagittal plane of the dummy vertically and parallel to the vehicle's longitudinal centerline and the same distance from the vehicle's longitudinal centerline, within ± 10 mm (± 0.4 in), as the center of the steering wheel. In the case of vehicles equipped with bucket seats, position the midsagittal plane of the dummy vertically such that it coincides with the longitudinal centerline of the seat cushion, within ± 10 mm (± 0.4 in).
- (b) Position the dummy in a kneeling position in the right front outboard passenger designated seating position ~~vehicle~~-seat with the dummy facing the front of the vehicle with its toes at the intersection of the seat back and seat cushion. Position the dummy so that the spine is vertical. Push down on the legs so that they contact the seat as much as possible and then release. Place the arms parallel to the spine.
- (c) If necessary use a material with a maximum breaking strength of 311 N (70 lb) or spacer blocks to keep the dummy in position.

- (d) Start the vehicle engine or place the ignition switch in the “on” position, whichever will turn on the suppression system, and then close all vehicle doors.
- (e) Wait 10 seconds, then check whether the air bag is deactivated.

S22.2.2.7 *Kneeling on seat, facing rearward.*

- (a) In the case of vehicles equipped with bench seats, position the midsagittal plane of the dummy vertically and parallel to the vehicle's longitudinal centerline and the same distance from the vehicle's longitudinal centerline, within ± 10 mm (± 0.4 in), as the center of the steering wheel. In the case of vehicles equipped with bucket seats, position the midsagittal plane of the dummy vertically such that it coincides with the longitudinal centerline of the seat cushion, within ± 10 mm (± 0.4 in).
- (b) Position the dummy in a kneeling position in the right front outboard passenger designated seating position ~~vehicle~~ seat with the dummy facing the rear of the vehicle. Position the dummy such that the dummy's head and torso are in contact with the seat back. Push down on the legs so that they contact the seat as much as possible and then release. Place the arms parallel to the spine.
- (c) Start the vehicle engine or place the ignition switch in the “on” position, whichever will turn on the suppression system, and then close all vehicle doors.
- (d) Wait 10 seconds, then check whether the air bag is deactivated.

S22.2.2.8 *Lying on seat.* This test is performed only in vehicles with 3 designated front seating positions.

- (a) Lay the dummy on the right front outboard passenger designated seating position ~~vehicle~~ seat such that the following criteria are met:
 - (1) The midsagittal plane of the dummy is horizontal,
 - (2) The dummy's spine is perpendicular to the vehicle's longitudinal axis,
 - (3) The dummy's arms are parallel to its spine,
 - (4) A plane passing through the two shoulder joints of the dummy vertical,
 - (5) The anterior of the dummy is facing the vehicle front,
 - (6) The head of the dummy is positioned towards the passenger door, and
 - (7) The horizontal distance from the topmost point of the dummy's head to the vehicle door is 50 to 100 mm (2–4 in).
 - (8) The dummy is as far back in the seat as possible.
- (b) Rotate the thighs as much as possible toward the chest of the dummy and rotate the legs as much as possible against the thighs.

- (c) Move the dummy's upper left arm parallel to the vehicle's transverse plane and the lower left arm 90 degrees to the upper arm. Rotate the lower left arm about the elbow joint and toward the dummy's head until movement is obstructed.
- (d) Start the vehicle engine or place the ignition switch in the "on" position, whichever will turn on the suppression system, and then close all vehicle doors.
- (e) Wait 10 seconds, then check whether the air bag is deactivated.

S22.3 Static tests of automatic suppression feature which shall result in activation of the passenger air bag system

S22.3.1 Each vehicle ~~certified to~~ that conforms to this option shall comply in tests conducted with the right front outboard ~~passenger~~ designated seating position at the mid-height, in the full rearward, and middle positions determined in S22.1.7.4, and the forward position determined in S16.3.3.1.8.

S22.3.2 Place a 49 CFR part 572 subpart O 5th percentile adult female test dummy at the right front outboard ~~passenger~~ designated seating position of the vehicle, in accordance with procedures specified in S16.3.3 of this TSD standard, except as specified in S22.3.1. Do not fasten the seat belt assembly.

S22.3.3 Start the vehicle engine or place the ignition switch in the "on" position, whichever will turn on the suppression system, and then close all vehicle doors.

S22.3.4 Wait 10 seconds, then check whether the air bag system is activated.

S22.4 Low risk deployment tests

S22.4.1 Each vehicle that conforms ~~is certified as complying~~ with S21.4 shall meet the following test requirements with the 49 CFR part 572, subpart P 3-year-old child dummy in both of the following positions: Position 1 (S22.4.2) and Position 2 (S22.4.3).

S22.4.1.1 Locate and mark a point on the front of the dummy's chest jacket on the midsagittal plane that is 114 mm (4.5 in) ± 3 mm (± 0.1 in) along the surface of the skin from the top of the skin at the neck line. This is referred to as "Point 1."

S22.4.1.2 Mark a point on the instrument panel that is longitudinally and transversely, as measured along the surface of the instrument panel, within ± 6 mm (± 0.2 in) of the point that is defined by the intersection of the instrument panel and a line between the volumetric center of the smallest volume that can encompass the folded undeployed air bag and the volumetric center of the static fully inflated air bag.

S22.4.1.3 Locate the vertical plane parallel to the vehicle longitudinal centerline through the point located in S22.4.1.2. This is referred to as "Plane D."

S22.4.1.4 Locate the horizontal plane through the point located in S22.4.1.2. This is referred to as "Plane C."

S22.4.2 *Position 1 (chest on instrument panel).*

S22.4.2.1 Set the seat and seat cushion in the positions determined in S16.2.10.3.1. If the seat back is adjustable independent of the seat, place the seat back at the manufacturer's nominal design seat back angle for a 50th percentile adult male as specified in S8.1.3. Position any adjustable parts of the seat that provide additional support so that they are in the lowest or most open adjustment position. If adjustable, set the head restraint in the lowest and most forward position.

S22.4.2.2 Place the dummy in the right front outboard passenger designated seating position seat such that:

S22.4.2.2.1 The midsagittal plane is coincident with Plane D within ± 10 mm (± 0.4 in).

S22.4.2.2.2 The legs are initially vertical to the floor pan. The legs and thighs shall be adjusted to the extent necessary for the head/torso to contact the instrument panel as specified in S22.4.2.3.

S22.4.2.2.3 The upper arms are parallel to the torso and the hands are in contact with the thighs.

S22.4.2.3 Without changing the seat position and with the dummy's thorax instrument cavity rear face vertical, move the dummy forward until the dummy head/torso contacts the instrument panel. If the dummy loses contact with the seat cushion because of the forward movement, maintain the height of the dummy and the angle of the thigh with respect to the torso. Once contact is made, raise the dummy vertically until Point 1 lies in Plane C within ± 10 mm (± 0.4 in). If the dummy's head contacts the windshield and keeps Point 1 from reaching Plane C, lower the dummy until there is no more than 5 mm (0.2 in) clearance between the head and the windshield. (The dummy shall remain in contact with the instrument panel while being raised or lowered, which may change the dummy's fore-aft position.)

S22.4.2.4 If possible, position the legs of the dummy so that the legs are vertical and the feet rest flat on the floor pan of the vehicle. If the positioning against the instrument panel does not allow the feet to be on the floor pan, the feet shall be parallel to the floor pan.

S22.4.2.5 If necessary, material with a maximum breaking strength of 311 N (70 lb) and spacer blocks may be used to support the dummy in position. The material should support the torso rather than the head. Support the dummy so that there is minimum interference with the full rotational and translational freedom for the upper torso of the dummy and the material does not interfere with the air bag.

S22.4.3 *Position 2 (head on instrument panel).*

S22.4.3.1 Place the right front outboard passenger designated seating position seat at the mid-height, in full rearward seating position determined in S22.1.7.4. Place the seat back, if adjustable independent of the seat, at the manufacturer's nominal design seat back angle for a 50th percentile adult male as specified in S8.1.3. Position any adjustable parts of the seat that provide additional support so that they are in the lowest or most open adjustment position. If adjustable, set the head restraint in the lowest and most forward position.

S22.4.3.2 Place the dummy in the right front outboard passenger designated seating position seat such that:

S22.4.3.2.1 The midsagittal plane is coincident with Plane D within ± 10 mm (± 0.4 in).

S22.4.3.2.2 The legs are vertical to the floor pan, the back of the legs are in contact with the seat cushion, and the dummy's thorax instrument cavity rear face is vertical. If it is not possible to position the dummy with the legs in the prescribed position, rotate the legs forward until the dummy is resting on the seat with the feet positioned flat on the floor pan, and the back of the legs are in contact with the front of the seat cushion. Set the transverse distance between the longitudinal centerlines at the front of the dummy's knees at 86 to 91 mm (3.4 to 3.6 in), with the thighs and the legs of the dummy in vertical planes.

S22.4.3.2.3 The upper arms are parallel to the torso and the hands are in contact with the thighs.

S22.4.3.3 Using only the control that primarily moves the seat in the fore and aft direction, move the seat forward, while maintaining the thorax instrument cavity rear face orientation until any part of the dummy contacts the vehicle's instrument panel.

S22.4.3.4 If dummy contact has not been made with the vehicle's instrument panel at the full forward seating position of the seat, slide the dummy forward until contact is made. Maintain the thorax instrument cavity rear face vertical orientation. If the dummy loses contact with the seat, from that point forward, maintain the height of the dummy. Except as provided in S22.4.3.5, maintain the angle of the thigh with respect to the horizontal.

S22.4.3.5 If head/torso contact with the instrument panel has not been made, maintain the angle of the thighs with respect to the horizontal while applying a force towards the front of the vehicle on the spine of the dummy between the shoulder joints, perpendicular to the thorax instrument cavity rear face, until the head or torso comes into contact with the vehicle's instrument panel or until a maximum force of 222 N (50 lb) is achieved. If the head/torso is still not in contact with the instrument panel, hold the femurs and release the 222 N (50 lb) force. While maintaining the relative angle between the torso and the femurs, roll the dummy on the seat cushion, without sliding, until head/torso contact with the instrument panel is achieved. If seat contact is lost prior to or during femur rotation out of the horizontal plane, constrain the dummy to rotate about the dummy H-point. If the dummy cannot be rolled forward on the seat due to contact of the dummy feet with the floor pan, extend the lower legs forward, at the knees, until floor pan contact is avoided.

S22.4.3.6 If necessary, material with a maximum breaking strength of 311 N (70 lb) and spacer blocks may be used to support the dummy in position. The material should support the torso rather than the head. Support the dummy that there is minimum interference with the full rotational and translational freedom for the upper torso of the dummy and the material does not interfere with the air bag.

S22.4.4 Deploy the right front outboard passenger designated seating position frontal air bag system. If the frontal air bag system contains a multistage inflator, the vehicle shall be able to comply with the injury criteria at any stage or combination of stages or time delay between

successive stages that could occur in a fixed collision rigid barrier crash test at or below 26 km/h (16 mph), under the test procedure specified in S22.5.

S22.5 Test procedure for determining stages of air bag systems subject to low risk deployment (low speed crashes) test requirement

S22.5.1 The test described in S22.5.2 shall be conducted with an unbelted 50th percentile adult male test dummy in the driver seating position according to S8 as it applies to that seating position and an unbelted 5th percentile adult female test dummy either in the right front outboard passenger designated vehicle seating position according to S16 as it applies to that seating position or at any fore-aft seat position on the passenger side.

S22.5.2 Impact the vehicle traveling longitudinally forward at any speed, up to and including 26 km/h (16 mph) into a fixed collision rigid barrier that is perpendicular ± 5 degrees to the line of travel of the vehicle under the applicable conditions of S8, S10, and S16 excluding S10.7, S10.8, S10.9, and S16.3.5.

S22.5.3 Determine which inflation stage or combination of stages are fired and determine the time delay between successive stages. That stage or combination of stages, with time delay between successive stages, shall be used in deploying the air bag when conducting the low risk deployment tests described in S22.4, S24.4, and S26.

S22.5.4 If the air bag does not deploy in the impact described in S22.5.2, the low risk deployment tests described in S22.4, S24.4, and S26 shall be conducted with all stages using the maximum time delay between stages.

S23. Requirements using 6-year-old child dummies

S23.1 Each vehicle that ~~is conforms certified as complying~~ with S14 shall, at the option of the manufacturer, meet the requirements specified in S23.2, S23.3, or S23.4, under the test procedures specified in S24 or S28, as applicable.

S23.2 *Option 1—Automatic suppression feature.* Each vehicle shall meet the requirements specified in S23.2.1 through S23.2.3.

S23.2.1 The vehicle shall be equipped with an automatic suppression feature for the passenger frontal air bag system which results in deactivation of the air bag during each of the static tests specified in S24.2 (using the 49 CFR part 572 subpart N 6-year-old child dummy in any of the child restraints systems specified in section D of appendix A or A-1 of this TSD standard, as appropriate), and activation of the air bag system during each of the static tests specified in S24.3 (using the 49 CFR part 572 subpart O 5th percentile adult female dummy).

S23.2.2 The vehicle shall be equipped with a tell-tale light meeting the requirements specified in S19.2.2.

S23.2.3 The vehicle shall be equipped with a mechanism that indicates whether the air bag is suppressed, regardless of whether the passenger seat is occupied. The mechanism need not be located in the occupant compartment unless it is the tell-tale described in S23.2.2.

S23.3 *Option 2—Dynamic automatic suppression system that suppresses the air bag when an occupant is out of position.* (This option is available under the conditions set forth in S27.1.) The vehicle shall be equipped with a dynamic automatic suppression system for the passenger frontal air bag system which meets the requirements specified in S27.

S23.4 *Option 3—Low risk deployment.* Each vehicle shall meet the injury criteria specified in S23.5 of this ~~TSD standard~~ when the passenger air bag is statically deployed in accordance with both of the low risk deployment test procedures specified in S24.4.

S23.5 Injury criteria for the 49 CFR part 572 subpart N 6-year-old child dummy

S23.5.1 All portions of the test dummy shall be contained within the outer surfaces of the vehicle ~~passenger~~ occupant compartment.

S23.5.2 *Head injury criteria.*

- (a) For any two points in time, t_1 and t_2 , during the event which are separated by not more than a 15 millisecond time interval and where t_1 is less than t_2 , the head injury criterion (HIC_{15}) shall be determined using the resultant head acceleration at the center of gravity of the dummy head, a_r , expressed as a multiple of g (the acceleration of gravity) and shall be calculated using the expression:

$$\left[\frac{1}{(t_2 - t_1)} \int_{t_1}^{t_2} a_r dt \right]^{2.5} (t_2 - t_1)$$

- (b) The maximum calculated HIC_{15} value shall not exceed 700.

S23.5.3 The resultant acceleration calculated from the output of the thoracic instrumentation shall not exceed 60 g 's, except for intervals whose cumulative duration is not more than 3 milliseconds.

S23.5.4 Compression deflection of the sternum relative to the spine, as determined by instrumentation, shall not exceed 40 mm (1.6 in).

S23.5.5 *Neck injury.* When measuring neck injury, each of the following injury criteria shall be met.

- (a) N_{ij} .

- (1) The shear force (F_x), axial force (F_z), and bending moment (M_y) shall be measured by the dummy upper neck load cell for the duration of the crash event as specified in S4.11. Shear force, axial force, and bending moment shall be filtered for N_{ij} purposes at SAE J211/1 MAR95 (~~incorporated by reference~~, see

the list at 49 CFR Part §571.5 paragraph (k) for the full citation) Channel Frequency Class 600.

- (2) During the event, the axial force (F_z) can be either in tension or compression while the occipital condyle bending moment (M_{oc}) can be in either flexion or extension. This results in four possible loading conditions for N_{ij} : tension-extension (N_{te}), tension-flexion (N_{tf}), compression-extension (N_{ce}), or compression-flexion (N_{cf}).
- (3) When calculating N_{ij} using equation S23.5.5(a)(4), the critical values, F_{zc} and M_{yc} , are:
 - (i) $F_{zc} = 2800 \text{ N (629 lbf)}$ when F_z is in tension
 - (ii) $F_{zc} = 2800 \text{ N (629 lbf)}$ when F_z is in compression
 - (iii) $M_{yc} = 93 \text{ Nm (69 lbf-ft)}$ when a flexion moment exists at the occipital condyle
 - (iv) $M_{yc} = 37 \text{ Nm (27 lbf-ft)}$ when an extension moment exists at the occipital condyle.
- (4) At each point in time, only one of the four loading conditions occurs and the N_{ij} value corresponding to that loading condition is computed and the three remaining loading modes shall be considered a value of zero. The expression for calculating each N_{ij} loading condition is given by:
$$N_{ij} = (F_z / F_{zc}) + (M_{oc} / M_{yc})$$
- (5) None of the four N_{ij} values shall exceed 1.0 at any time during the event.
 - (b) *Peak tension.* Tension force (F_z), measured at the upper neck load cell, shall not exceed 1490 N (335 lbf) at any time.
 - (c) *Peak compression.* Compression force (F_z), measured at the upper neck load cell, shall not exceed 1820 N (409 lbf) at any time.

S23.5.6 Unless otherwise indicated, instrumentation for data acquisition, data channel frequency class, and moment calculations are the same as given for the 49 CFR part 572 subpart N 6-year-old child test dummy.

S24. Test procedure for S23

S24.1 General provisions and definitions

S24.1.1 Tests specifying the use of a booster seat may be conducted using any such restraint listed in section D of appendix A or A-1 of this TSD standard, as appropriate. The booster seat may be unused or have been previously used only for automatic suppression tests. If it has been used, there shall not be any visible damage prior to the test. Booster seats are to be

used in the manner appropriate for a 6-year-old child of the same height and weight as the 6-year-old child dummy.

S24.1.2 Unless otherwise specified, each vehicle ~~certified to~~ that conforms to this option shall comply in tests conducted with the right front outboard passenger designated seating position at the mid-height, in the full rearward seat track position, the middle seat track position, and the full forward seat track position as determined in this section. Using only the control that primarily moves the seat in the fore and aft direction, determine the full rearward, middle, and full forward positions of the SCRP. Using any seat or seat cushion adjustments other than that which primarily moves the seat fore-aft, determine the SCRP mid-point height for each of the three fore-aft test positions, while maintaining as closely as possible, the seat cushion angle determined in S16.2.10.3.1. Set the seat back angle, if adjustable independent of the seat, at the manufacturer's nominal design seat back angle for a 50th percentile adult male as specified in S8.1.3. If the dummy contacts the vehicle interior, move the seat rearward to the next detent that provides clearance. If the seat is a power seat, move the seat rearward while assuring that there is a maximum of 5 mm (0.2 in) distance between the vehicle interior and the point on the dummy that would first contact the vehicle interior.

S24.1.3 Except as otherwise specified, if the booster seat has an anchorage lower connector system as specified in S5.9 of FMVSS No. 213 and is used under this TSD standard in testing a vehicle with a right front outboard passenger designated seating position vehicle seat that has an lower universal anchorage system as specified in FMVSS No. 225, the vehicle shall comply with the belted test conditions with the ~~restraint anchorage lower connector~~ lower connector system attached to the ~~FMVSS No. 225 vehicle seat lower universal anchorage system and the vehicle seat belt assembly unattached~~. It shall also comply with the belted test conditions with the ~~restraint anchorage lower connector~~ lower connector system unattached to the ~~FMVSS No. 225 vehicle seat lower universal anchorage system and the vehicle seat belt assembly attached~~. The vehicle shall comply with the unbelted test conditions with the ~~restraint anchorage lower connector~~ lower connector system unattached to the ~~FMVSS No. 225 vehicle seat anchorage lower universal system~~.

S24.1.4 Do not attach any tether straps.

S24.1.5 The definitions provided in S16.3.1 through S16.3.10 apply to the tests specified in S24.

S24.1.6 For leg and thigh angles, use the following references:

S24.1.6.1 *Thigh* —a straight line on the thigh skin between the center of the 5/16–18 UNC–2B threaded access hole in the upper leg clamp (drawing 127–4004, 6 YR H3—upper leg clamp) and the knee screw (part 9000248 in drawing 127–4000–1 & –2, leg assembly).

S24.1.6.2 *Leg* —a straight line on the leg skin between the center of the lower leg screw (part 9001170 in drawing 127–4000–1 & –2, leg assembly) and the knee screw (part 9000248 in drawing 127–4000–1 & –2, leg assembly).

S24.2 *Static tests of automatic suppression feature which shall result in deactivation of the passenger air bag.* Each vehicle that is conforms ~~certified as complying with S23.2 of~~

FMVSS No. 208 shall meet the following test requirements with the child restraint in the right front outboard passenger designated seating position vehicle seat under the following conditions:

- (a) Using the vehicle seat belt assemblies ~~safety belts~~ as specified in S22.2.1.5 with section D child restraints designed to be secured to the vehicle seat even when empty;
- (b) If the ~~child restraint is certified to S5.9 of §571.213, and the~~ vehicle seat has an lower universal anchorage system ~~as specified in §571.225, using~~ use only the mechanism provided by the child restraint manufacturer for attachment to the lower universal anchorage system as specified in S22.2.1.6; and
- (c) Without securing the child restraint with either the vehicle seat belt assemblies ~~safety belts~~ or any mechanism provided with a the child restraint certified to S5.9 of §571.213.

S24.2.1 Except as provided in S24.2.2, conduct all tests as specified in S22.2, except that the 49 CFR part 572 subpart N 6-year-old child dummy shall be used.

S24.2.2 *Exceptions.* The tests specified in the following paragraphs of S22.2 need not be conducted: S22.2.1.7, S22.2.2.3, S22.2.2.5, S22.2.2.6, S22.2.2.7, and S22.2.2.8.

S24.2.3 *Sitting back in the seat and leaning on the right front outboard passenger designated seating position door.*

- (a) Place the dummy in the seated position in the right front outboard passenger designated seating position ~~vehicle~~ seat. For bucket seats, position the midsagittal plane of the dummy vertically such that it coincides with the longitudinal centerline of the seat cushion, within ± 10 mm (± 0.4 in). For bench seats, position the midsagittal plane of the dummy vertically and parallel to the vehicle's longitudinal centerline and the same distance from the longitudinal centerline of the vehicle, within ± 10 mm (± 0.4 in), as the center of the steering wheel.
- (b) Place the dummy's back against the seat back and rest the dummy's thighs on the seat cushion.
- (c) Allow the legs and feet of the dummy to extend off the surface of the seat. If this positioning of the dummy's legs is prevented by contact with the instrument panel, using only the control that primarily moves the seat fore and aft, move the seat rearward to the next detent that provides clearance. If the seat is a power seat, move the seat rearward, while assuring that there is a maximum of 5 mm (0.2 in) distance between the vehicle interior and the part of the dummy that was in contact with the vehicle interior.
- (d) Rotate the dummy's upper arms toward the seat back until they make contact.
- (e) Rotate the dummy's lower arms down until they contact the seat.
- (f) Close the vehicle's passenger-side door and then start the vehicle engine or place the ignition switch in the "on" position, whichever will turn on the suppression system.

- (g) Push against the dummy's left shoulder to lean the dummy against the door; close all remaining doors.
- (h) Wait ten seconds, then check whether the air bag is deactivated.

S24.3 Static tests of automatic suppression feature which shall result in activation of the passenger air bag system

S24.3.1 Each vehicle ~~certified to~~ that conforms to this option shall comply in tests conducted with the right front outboard ~~passenger~~ designated seating position at the mid-height, in the full rearward and middle positions determined in S24.1.2, and the forward position determined in S16.3.3.1.8.

S24.3.2 Place a 49 CFR part 572 subpart O 5th percentile adult female test dummy-at the right front outboard ~~passenger~~ designated seating position of the vehicle, in accordance with procedures specified in S16.3.3 of this TSD standard, except as specified in S24.3.1. Do not fasten the seat belt assembly.

S24.3.3 Start the vehicle engine or place the ignition switch in the "on" position, whichever will turn on the suppression system, and then close all vehicle doors.

S24.3.4 Wait 10 seconds, then check whether the air bag system is activated.

S24.4 Low risk deployment tests

S24.4.1 Each vehicle that conforms ~~is certified as complying with~~ S23.4 shall meet the following test requirements with the 49 CFR part 572, subpart N 6-year-old child dummy in both of the following positions: Position 1 (S24.4.2) or Position 2 (S24.4.3).

S24.4.1.1 Locate and mark a point on the front of the dummy's jacket on the midsagittal plane that is 139 mm (5.5 in) ± 3 mm (± 0.1 in) along the surface of the skin from the top of the skin at the neckline. This is referred to as "Point 1."

S24.4.1.2 Mark a point on the instrument panel that is longitudinally and transversely, as measured along the surface of the instrument panel, within ± 6 mm (± 0.2 in) of the point that is defined by the intersection of the instrument panel and a line between the volumetric center of the smallest volume that can encompass the folded undeployed air bag and the volumetric center of the static fully inflated air bag.

S24.4.1.3 Locate the vertical plane parallel to the vehicle longitudinal centerline through the point located in S24.4.1.2. This is referred to as "Plane D."

S24.4.1.4 Locate the horizontal plane through the point located in S24.4.1.2. This is referred to as "Plane C."

S24.4.2 *Position 1 (chest on instrument panel).*

S24.4.2.1 Set the seat and seat cushion in the positions determined in S16.2.10.3.1. If the seat back is adjustable independent of the seat, place the seat back at the manufacturer's nominal design seat back angle for a 50th percentile adult male as specified in S8.1.3. Position any

adjustable parts of the seat that provide additional support so that they are in the lowest or most open adjustment position. If adjustable, set the head restraint in the lowest and most forward position.

S24.4.2.2 Remove the legs of the dummy at the pelvic interface.

S24.4.2.3 Place the dummy in the right front outboard passenger designated seating position seat such that:

- (a) The midsagittal plane is coincident with Plane D within ± 10 mm (± 0.4 in).
- (b) The upper arms are parallel to the torso and the hands are next to where the thighs would be.
- (c) Without changing the seat position and with the dummy's thorax instrument cavity rear face 6 degrees forward of the vertical, move the dummy forward until the dummy head/torso contacts the instrument panel. If the dummy loses contact with the seat cushion because of the forward movement, maintain the height of the dummy while moving the dummy forward. If the head contacts the windshield before head/torso contact with the instrument panel, maintain the thorax instrument cavity angle and move the dummy forward such that the head is following the angle of the windshield until there is head/torso contact with the instrument panel. Once contact is made, raise or lower the dummy vertically until Point 1 lies in Plane C within ± 10 mm (± 0.4 in). If the dummy's head contacts the windshield and keeps Point 1 from reaching Plane C, lower the dummy until there is no more than 5 mm (0.2 in) clearance between the head and the windshield. (The dummy shall remain in contact with the instrument panel while being raised or lowered which may change the dummy's fore-aft position.)

S24.4.2.4 If necessary, material with a maximum breaking strength of 311 N (70 lb) and spacer blocks may be used to support the dummy in position. The material should support the torso rather than the head. Support the dummy so that there is minimum interference with the full rotational and translational freedom for the upper torso of the dummy and the material does not interfere with the air bag.

S24.4.3 *Position 2 (head on instrument panel).*

S24.4.3.1 Place the right front outboard passenger designated seating position seat at the mid-height full rearward seating position determined in S24.1.2. Place the seat back, if adjustable independent of the seat, at the manufacturer's nominal design seat back angle for a 50th percentile adult male as specified in S8.1.3. Position any adjustable parts of the seat that provide additional support so that they are in the lowest or most open adjustment position. Position an adjustable head restraint in the lowest and most forward position.

S24.4.3.2 Place the dummy in the right front outboard passenger designated seating position seat such that:

- (a) The midsagittal plane is coincident with Plane D within ± 10 mm (± 0.4 in).

- (b) The legs are perpendicular to the floor pan, the back of the legs are in contact with the seat cushion, and the dummy's thorax instrument cavity rear face is 6 degrees forward of vertical. If it is not possible to position the dummy with the legs in the prescribed position, rotate the legs forward until the dummy is resting on the seat with the feet positioned flat on the floor pan and the back of the legs are in contact with the front of the seat cushion. Set the transverse distance between the longitudinal centerlines at the front of the dummy's knees at 112 to 117 mm (4.4 to 4.6 in), with the thighs and the legs of the dummy in vertical planes.
- (c) The upper arms are parallel to the torso and the hands are in contact with the thighs.

S24.4.3.3 Using only the control that primarily moves the seat in the fore and aft direction, move the seat forward, while maintaining the thorax instrument cavity rear face orientation until any part of the dummy contacts the vehicle's instrument panel.

S24.4.3.4 If dummy contact has not been made with the vehicle's instrument panel at the full forward seating position of the seat, slide the dummy forward on the seat until contact is made. Maintain the thorax instrument cavity rear face orientation. If the dummy loses contact with the seat, from that point forward maintain the height of the dummy. Except as provided in S24.4.3.5, maintain the angle of the thigh with respect to the horizontal.

S24.4.3.5 If head/torso contact with the instrument panel has not been made, maintain the angle of the thighs with respect to the horizontal while applying a force towards the front of the vehicle on the spine of the dummy between the shoulder joints, perpendicular to the thorax instrument cavity rear face, until the head or torso comes into contact with the vehicle's instrument panel or until a maximum force of 222 N (50 lb) is achieved. If the head/torso is still not in contact with the instrument panel, hold the femurs and release the 222 N (50 lb) force. While maintaining the relative angle between the torso and the femurs, roll the dummy forward on the seat cushion, without sliding, until head/torso contact with the instrument panel is achieved. If seat contact is lost prior to or during femur rotation out of the horizontal plane, constrain the dummy to rotate about the dummy H-point. If the dummy cannot be rolled forward on the seat due to contact of the dummy feet with the floor pan, extend the lower legs forward, at the knees, until floor pan contact is avoided.

S24.4.3.6 If necessary, material with a maximum breaking strength of 311 N (70 lb) and spacer blocks may be used to support the dummy in position. The material should support the torso rather than the head. Support the dummy so that there is minimum interference with the full rotational and translational freedom for the upper torso of the dummy and the material does not interfere with the air bag.

S24.4.4 Deploy the right front outboard passenger designated seating position frontal air bag system. If the frontal air bag system contains a multistage inflator, the vehicle shall be able to comply with the injury criteria at any stage or combination of stages or time delay between successive stages that could occur in a fixed collision rigid barrier crash test at or below 26 km/h (16 mph), under the test procedure specified in S22.5.

S25. Requirements using an out-of-position 5th percentile adult female dummy at the driver position

S25.1 Each vehicle ~~conforming certified as complying~~ with S14 shall, at the option of the manufacturer, meet the requirements specified in S25.2 or S25.3 under the test procedures specified in S26 or S28, as appropriate.

S25.2 *Option 1—Dynamic automatic suppression system that suppresses the air bag when the driver is out of position.* (This option is available under the conditions set forth in S27.1.) The vehicle shall be equipped with a dynamic automatic suppression system for the driver air bag which meets the requirements specified in S27.

S25.3 *Option 2—Low risk deployment.* Each vehicle shall meet the injury criteria specified by S15.3 of this TSD standard, except as modified in S25.4, when the driver air bag is statically deployed in accordance with both of the low risk deployment test procedures specified in S26.

S25.4 *Neck injury criteria driver low risk deployment tests.* When measuring neck injury in low risk deployment tests for the driver position, each of the following neck injury criteria shall be met.

(a) *Nij.*

- (1) The shear force (F_x), axial force (F_z), and bending moment (M_y) shall be measured by the dummy upper neck load cell for the duration of the crash event as specified in S4.11. Shear force, axial force, and bending moment shall be filtered for N_{ij} purposes at SAE J211/1 MAR 95 (~~incorporated by reference~~, see the list at 49 CFR Part §571.5 paragraph (k) for the full citation) Channel Frequency Class 600.
- (2) During the event, the axial force (F_z) can be either in tension or compression while the occipital condyle bending moment (M_{ocy}) can be in either flexion or extension. This results in four possible loading conditions for N_{ij} : tension-extension (N_{te}), tension-flexion (N_{tf}), compression-extension (N_{ce}), or compression-flexion (N_{cf}).
- (3) When calculating N_{ij} using equation S25.4(a)(4), the critical values, F_{zc} and M_{yc} , are:
 - (i) $F_{zc} = 3880 \text{ N (872 lbf)}$ when F_z is in tension
 - (ii) $F_{zc} = 3880 \text{ N (872 lbf)}$ when F_z is in compression
 - (iii) $M_{yc} = 155 \text{ Nm (114 lbf-ft)}$ when a flexion moment exists at the occipital condyle
 - (iv) $M_{yc} = 61 \text{ Nm (45 lbf-ft)}$ when an extension moment exists at the occipital condyle.
- (4) At each point in time, only one of the four loading conditions occurs and the N_{ij} value corresponding to that loading condition is computed and the three

remaining loading modes shall be considered a value of zero. The expression for calculating each N_{ij} loading condition is given by:

$$N_{ij} = (F_z / F_{zc}) + (M_{ocy} / M_{yc})$$

- (5) None of the four N_{ij} values shall exceed 1.0 at any time during the event.
- (b) *Peak tension.* Tension force (F_z), measured at the upper neck load cell, shall not exceed 2070 N (465 lbf) at any time.
- (c) *Peak compression.* Compression force (F_z), measured at the upper neck load cell, shall not exceed 2520 N (566 lbf) at any time.
- (d) Unless otherwise indicated, instrumentation for data acquisition, data channel frequency class, and moment calculations are the same as given in 49 CFR part 572 subpart O 5th percentile female test dummy.

S26. Procedure for low risk deployment tests of driver air bag

S26.1 Each vehicle that ~~conforms is certified as complying~~ with S25.3 shall meet the requirements of S25.3 and S25.4 with the 49 CFR part 572 subpart O 5th percentile adult female dummy in both of the following positions: Driver position 1 (S26.2) and Driver position 2 (S26.3).

S26.2 Driver position 1 (chin on module)

S26.2.1 Adjust the steering controls so that the steering wheel hub is at the geometric center of the locus it describes when it is moved through its full range of driving positions. If there is no setting at the geometric center, position it one setting lower than the geometric center. Set the rotation of the steering wheel so that the vehicle wheels are pointed straight ahead.

S26.2.2 Mark a point on the steering wheel cover that is longitudinally and transversely, as measured along the surface of the steering wheel cover, within ± 6 mm (± 0.2 in) of the point that is defined by the intersection of the steering wheel cover and a line between the volumetric center of the smallest volume that can encompass the folded undeployed air bag and the volumetric center of the static fully inflated air bag. Locate the vertical plane parallel to the vehicle longitudinal centerline through the point located on the steering wheel cover. This is referred to as "Plane E."

S26.2.3 Place the seat and seat cushion in the position achieved in S16.2.10.3.1. If the seat or seat cushion is adjustable in the vertical direction by adjustments other than that which primarily moves the seat or seat cushion fore-aft, determine the maximum and minimum heights of the SCRIP at this position, while maintaining the seat cushion reference line angle as closely as possible. Place the SCRIP in the mid-height position. If the seat back is adjustable independent of the seat, place the seat back at the manufacturer's nominal design seat back angle for a 50th percentile adult male as specified in S8.1.3. Position any adjustable parts of the seat that provide additional support so that they are in the lowest or most open

adjustment position. Position an adjustable head restraint in the lowest and most forward position.

S26.2.4 Place the dummy in the driver's seat such that:

S26.2.4.1 The midsagittal plane is coincident with Plane E within ± 10 mm (± 0.4 in).

S26.2.4.2 The legs are perpendicular to the floor pan and the back of the legs are in contact with the seat cushion. The legs may be adjusted if necessary to achieve the final head position.

S26.2.4.3 The dummy's thorax instrument cavity rear face is 6 degrees forward (toward the front of the vehicle) of the steering wheel angle (i.e., if the steering wheel angle is 25 degrees from vertical, the thorax instrument cavity rear face angle is 31 degrees).

S26.2.4.4 The initial transverse distance between the longitudinal centerlines at the front of the dummy's knees is 160 to 170 mm (6.3 to 6.7 in), with the thighs and legs of the dummy in vertical planes.

S26.2.4.5 The upper arms are parallel to the torso and the hands are in contact with the thighs.

S26.2.5 Maintaining the spine angle, slide the dummy forward until the head/torso contacts the steering wheel.

S26.2.6 While maintaining the spine angle, adjust the height of the dummy so that the bottom of the chin is in the same horizontal plane as the highest point of the air bag module cover (dummy height can be adjusted using the seat height adjustments and/or spacer blocks). If the seat prevents the bottom of the chin from being in the same horizontal plane as the module cover, adjust the dummy height to as close to the prescribed position as possible.

S26.2.7 If necessary, material with a maximum breaking strength of 311 N (70 lb) and spacer blocks may be used to support the dummy in position. The material should support the torso rather than the head. Support the dummy so that there is minimum interference with the full rotational and translational freedom for the upper torso of the dummy and the material does not interfere with the air bag.

S26.3 Driver position 2 (chin on rim).

S26.3.1 Place the seat and seat cushion in the position achieved in S16.2.10.3.1. If the seat or seat cushion is adjustable in the vertical direction by adjustments other than that which primarily moves the seat or seat cushion fore-aft, determine the maximum and minimum heights of the SCRCP at this position, while maintaining the seat cushion reference line angle as closely as possible. Place the SCRCP in the mid-height position. If the seat back is adjustable independent of the seat, place the seat back at the manufacturer's nominal design seat back angle for a 50th percentile adult male as specified in S8.1.3. Position any adjustable parts of the seat that provide additional support so that they are in the lowest or most open adjustment position. Position an adjustable head restraint in the lowest position.

S26.3.2 Adjust the steering controls so that the steering wheel hub is at the geometric center of the locus it describes when it is moved through its full range of driving positions. If there is no setting at the geometric center, position it one setting lower than the geometric center. Set the rotation of the steering wheel so that the vehicle wheels are pointed straight ahead.

S26.3.3 Mark a point on the steering wheel cover that is longitudinally and transversely, as measured along the surface of the steering wheel cover, within ± 6 mm (± 0.2 in) of the point that is defined by the intersection of the steering wheel cover and a line between the volumetric center of the smallest volume that can encompass the folded undeployed air bag and the volumetric center of the static fully inflated air bag. Locate the vertical plane parallel to the vehicle longitudinal centerline through the point located on the steering wheel cover. This is referred to as "Plane E."

S26.3.4 Place the dummy in the driver's seat position such that:

S26.3.4.1 The midsagittal plane is coincident with Plane E within ± 10 mm (± 0.4 in).

S26.3.4.2 The legs are perpendicular to the floor pan and the back of the legs are in contact with the seat cushion. The legs may be adjusted if necessary to achieve the final head position.

S26.3.4.3 The dummy's thorax instrument cavity rear face is 6 degrees forward (toward the front of the vehicle) of the steering wheel angle (i.e., if the steering wheel angle is 25 degrees from vertical, the thorax instrument cavity rear face angle is 31 degrees).

S26.3.4.4 The initial transverse distance between the longitudinal centerlines at the front of the dummy's knees is 160 to 170 mm (6.3 to 6.7 in), with the thighs and legs of the dummy in vertical planes.

S26.3.4.5 The upper arms are parallel to the torso and the hands are in contact with the thighs.

S26.3.5 Maintaining the spine angle, slide the dummy forward until the head/torso contacts the steering wheel.

S26.3.6 While maintaining the spine angle, position the dummy so that a point on the chin 40 mm (1.6 in) ± 3 mm (± 0.1 in) below the center of the mouth (chin point) is, within ± 10 mm (± 0.4 in), in contact with a point on the steering wheel rim surface closest to the dummy that is 10 mm (0.4 in) vertically below the highest point on the rim in Plane E. If the dummy's head contacts the vehicle windshield or upper interior before the prescribed position can be obtained, lower the dummy until there is no more than 5 mm (0.2 in) clearance between the vehicle's windshield or upper interior, as applicable.

S26.3.7 If the steering wheel can be adjusted so that the chin point can be in contact with the rim of the uppermost portion of the steering wheel, adjust the steering wheel to that position. If the steering wheel contacts the dummy's leg(s) prior to attaining this position, adjust it to the next highest detent, or if infinitely adjustable, until there is a maximum of 5 mm (0.2 in) clearance between the wheel and the dummy's leg(s). Readjust the dummy's torso such that the thorax instrument cavity rear face is 6 degrees forward of the steering wheel angle.

Position the dummy so that the chin point is in contact, or if contact is not achieved, as close as possible to contact with the rim of the uppermost portion of the steering wheel.

S26.3.8 If necessary, material with a maximum breaking strength of 311 N (70 lb) and spacer blocks may be used to support the dummy in position. The material should support the torso rather than the head. Support the dummy so that there is minimum interference with the full rotational and translational freedom for the upper torso of the dummy and the material does not interfere with the air bag.

S26.4 Deploy the driver frontal air bag system. If the frontal air bag system contains a multistage inflator, the vehicle shall be able to comply with the injury criteria at any stage or combination of stages or time delay between successive stages that could occur in a fixed collision rigid barrier crash test at or below 26 km/h (16 mph), under the test procedure specified in S22.5.

S27. Option for dynamic automatic suppression system that suppresses the air bag when an occupant is out-of-position

S27.1 Availability of option. This option is available for either air bag, singly or in conjunction, subject to the requirements of S27, if:

- (a) A petition for rulemaking to establish dynamic automatic suppression system test procedures is submitted pursuant to subpart B Chapter V, Title 49, part 552 of the Code of Federal Regulations and a test procedure applicable to the vehicle is added to S28 pursuant to the procedures specified by that subpart, or
- (b) A test procedure applicable to the vehicle is otherwise added to S28.

S27.2 Definitions. For purposes of S27 and S28, the following definitions apply:

Automatic suppression zone or ASZ means a three-dimensional zone adjacent to the air bag cover, specified by the vehicle manufacturer, where the deployment of the air bag will be suppressed by the DASS if a vehicle occupant enters the zone under specified conditions.

Dynamic automatic suppression system or DASS means a portion of an air bag system that automatically controls whether or not the air bag deploys during a crash by:

- (1) Sensing the location of an occupant, moving or still, in relation to the air bag;
- (2) Interpreting the occupant characteristics and location information to determine whether or not the air bag should deploy; and
- (3) Activating or suppressing the air bag system based on the interpretation of occupant characteristics and location information.

S27.3 Requirements

Each vehicle shall, at each applicable right front outboard designated seating position, when tested under the conditions of S28 of this standard, comply with the requirements specified in S27.4 through S27.6.

S27.4 Each vehicle shall be equipped with a DASS

S27.5 Static test requirement (low risk deployment for occupants outside the ASZ)

S27.5.1 Driver (49 CFR part 572 subpart O 5th percentile female dummy). Each vehicle shall meet the injury criteria specified in S15.3 of this standard when the driver air bag is deployed in accordance with the procedures specified in S28.1.

S27.5.2 Passenger (49 CFR part 572 subpart P 3-year-old child dummy and 49 CFR part 572 subpart N 6-year-old child dummy). Each vehicle shall meet the injury criteria specified in S21.5 and S23.5, as appropriate, when the passenger air bag is deployed in accordance with the procedures specified in S28.2.

S27.6 Dynamic test requirement (suppression of air bag for occupants inside the ASZ)

S27.6.1 Driver. The DASS shall suppress the driver air bag before the head, neck, or torso of the specified test device enters the ASZ when the vehicle is tested under the procedures specified in S28.3.

S27.6.2 Passenger. The DASS shall suppress the passenger air bag before head, neck, or torso of the specified test device enters the ASZ when the vehicle is tested under the procedures specified in S28.4.

S28. Test procedure for S27 of this standard. [Reserved]

S28.1 Driver suppression zone verification test (49 CFR part 572 Subpart O 5th percentile female dummy). [Reserved]

S28.2 Passenger suppression zone verification test (49 CFR part 572 subpart P 3-year-old child dummy and 49 CFR part 572 subpart N 6-year-old child dummies). [Reserved]

S28.3 Driver dynamic test procedure for DASS requirements. [Reserved]

S28.4 Passenger dynamic test procedure for DASS requirements. [Reserved]

S29. Manufacturer option for their vehicles to conform to certify vehicles to certain static suppression test requirements using human beings rather than test dummies

S29.1 At the option of the manufacturer, instead of using test dummies in conducting the tests for the following automatic suppression and occupant recognition parts of the low risk deployment test requirements, human beings may be used as specified. If human beings are used, they shall assume, to the extent possible, the final physical position specified for the corresponding dummies for each test.

- (a) If a manufacturer decides ~~to certify a~~ that their vehicle shall conform using a human being for a test of the passenger automatic suppression, it shall use humans for the entire series of tests, e.g., 3-year-old children for each test of the system involving 3-year-old test dummies. If a manufacturer decides to certify a vehicle using a test dummy for a test of the system, it shall use test dummies for the entire series of tests, e.g., a Hybrid III 3-year-old child dummy for each test of the system involving 3-year-old child test dummies.
- (b) For S19.2, instead of using the 49 CFR part 572 subpart R 12-month-old child dummy, a human child who weighs between 8.2 and 9.1 kg (18 and 20 lb), and who is between 61 and 66 cm (24 and 26 in) tall may be used.
- (c) For S19.2, instead of using the 49 CFR part 572 subpart K newborn infant dummy, a human child who weighs between 8.2 and 9.1 kg (18 and 20 lb), and who is between 61 and 66 cm (24 and 26 in) tall may be used.
- (d) For S21.2 and S21.5.1, instead of using the 49 CFR part 572 subpart P 3-year-old child dummy, a human child who weighs between 13.4 and 18 kg (29.5 and 39.5 lb), and who is between 89 and 99 cm (35 and 39 in) tall may be used.
- (e) For S23.2 and S23.5.1, instead of using the 49 CFR part 572 subpart N 6-year-old child dummy, a human child who weighs between 21 and 25.6 kg (46.5 and 56.5 lb), and who is between 114 and 124.5 cm (45 and 49 in) tall may be used.
- (f) For S19.2, S21.2, and S23.2, instead of using the 49 CFR part 572 subpart O 5th percentile adult female test dummy, a female who weighs between 46.7 and 51.25 kg (103 and 113 lb), and who is between 139.7 and 150 cm (55 and 59 in) tall may be used.

S29.2 Human beings shall be dressed in a cotton T-shirt, full length cotton trousers, and sneakers. Specified weights and heights include clothing.

S29.3 A manufacturer exercising this option shall upon request:

- (a) Provide ~~NHTSA with~~ a method to deactivate the air bag during compliance testing under S20.2, S20.3, S22.2, S22.3, S24.2, and S24.3, and identify any parts or equipment necessary for deactivation; such assurance may be made by removing the air bag; and
- (b) Provide ~~NHTSA with~~ a method to assure that the same test results would be obtained if the air bag were not deactivated.

Figures to ~~§571.208~~ TSD 208

Figure 1 (Reserved)

Figure 2 (Content not reproduced)

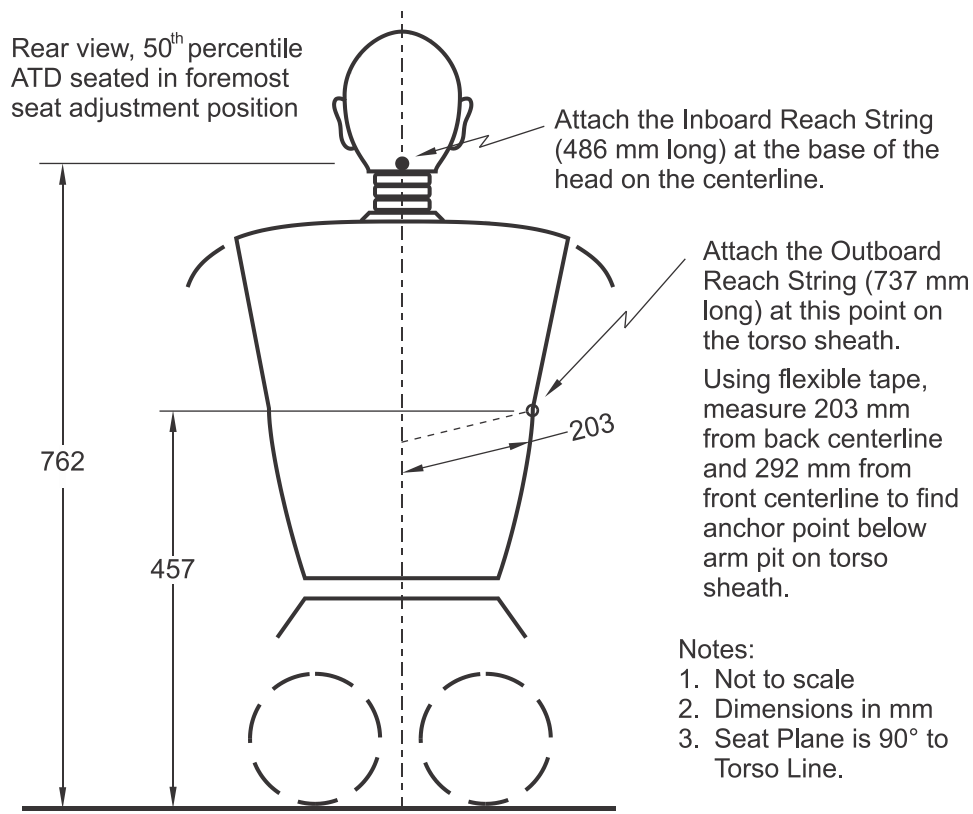

Figure 3 Location of Anchoring Points for Latchplate Reach Limiting Chains or Strings to Test for Latchplate Accessibility Using Subpart E Test Device

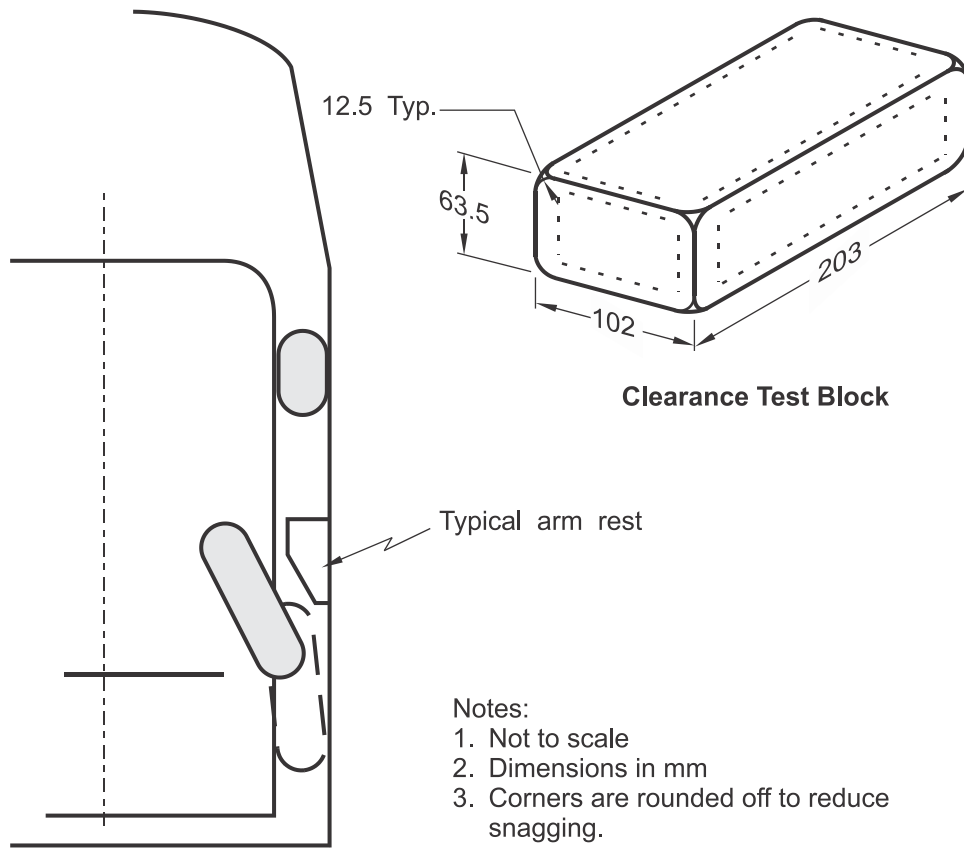
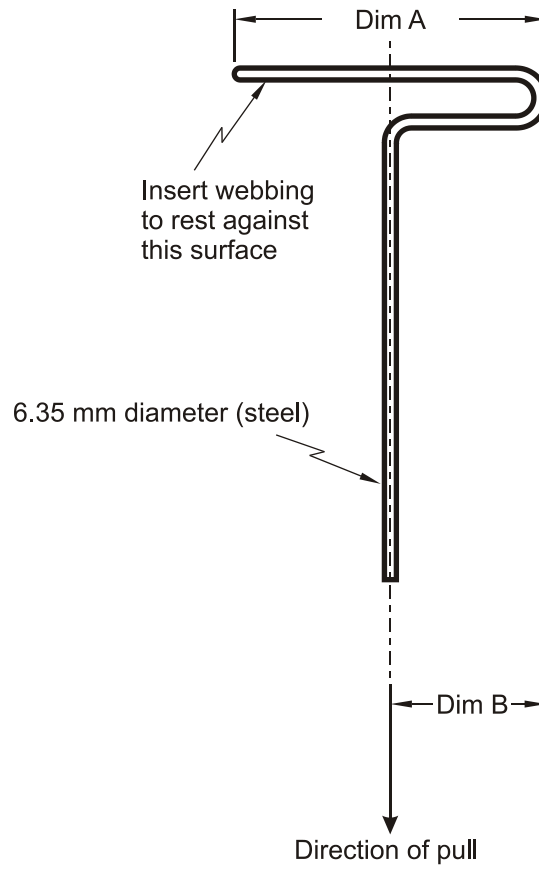

Figure 4 Use of Clearance Test Block to Determine Hand/Arm Access



- Notes:
1. Dim **A**: Width of webbing + 12.7 mm
 2. Dim **B**: $\frac{1}{2}$ of Dim **A**
 3. Not to scale

Figure 5 Webbing Tension Pull Device

Sled Pulse with Maximum and Minimum Corridors

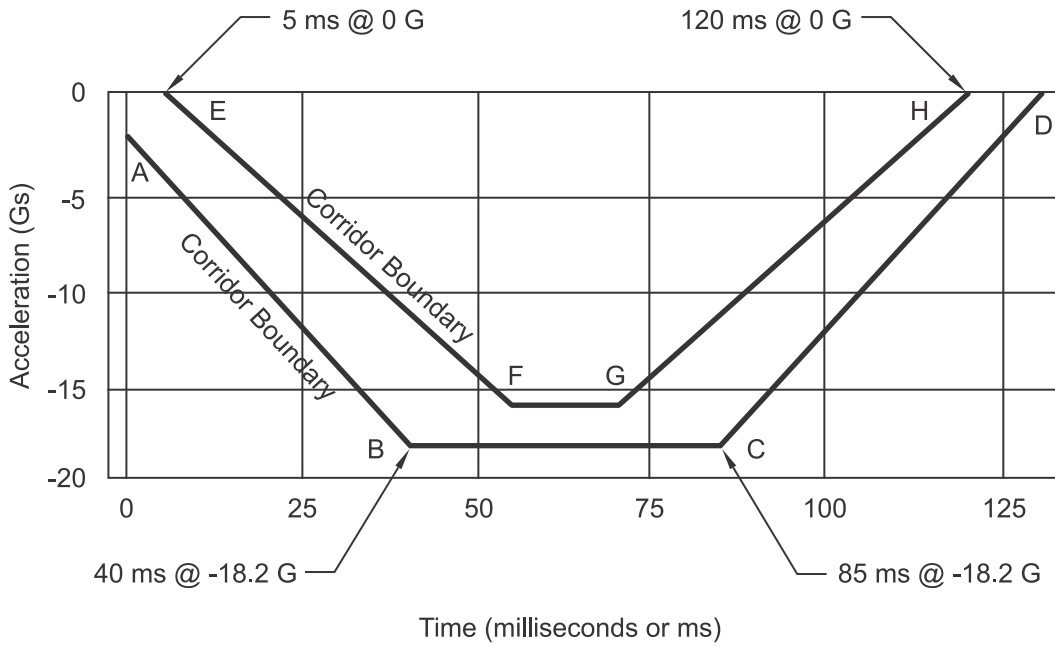

Figure 6 Sled and Pulse Coordinates

Sled Pulse and Coordinates

Reference Point	T(ms)	Acceleration (G)
A	0	-2
B	40	-18.2
C	85	-18.2
D	130	0
E	5	0
F	55	-16
G	70	-16
H	120	0.00

Figure 6a. [CONTENT NOT REPRODUCED]

Figure 6b. [CONTENT NOT REPRODUCED]

Figure 6c. [CONTENT NOT REPRODUCED]

Figure 7. [CONTENT NOT REPRODUCED]

Figure 8. [CONTENT NOT REPRODUCED]

Figure 9. [CONTENT NOT REPRODUCED]

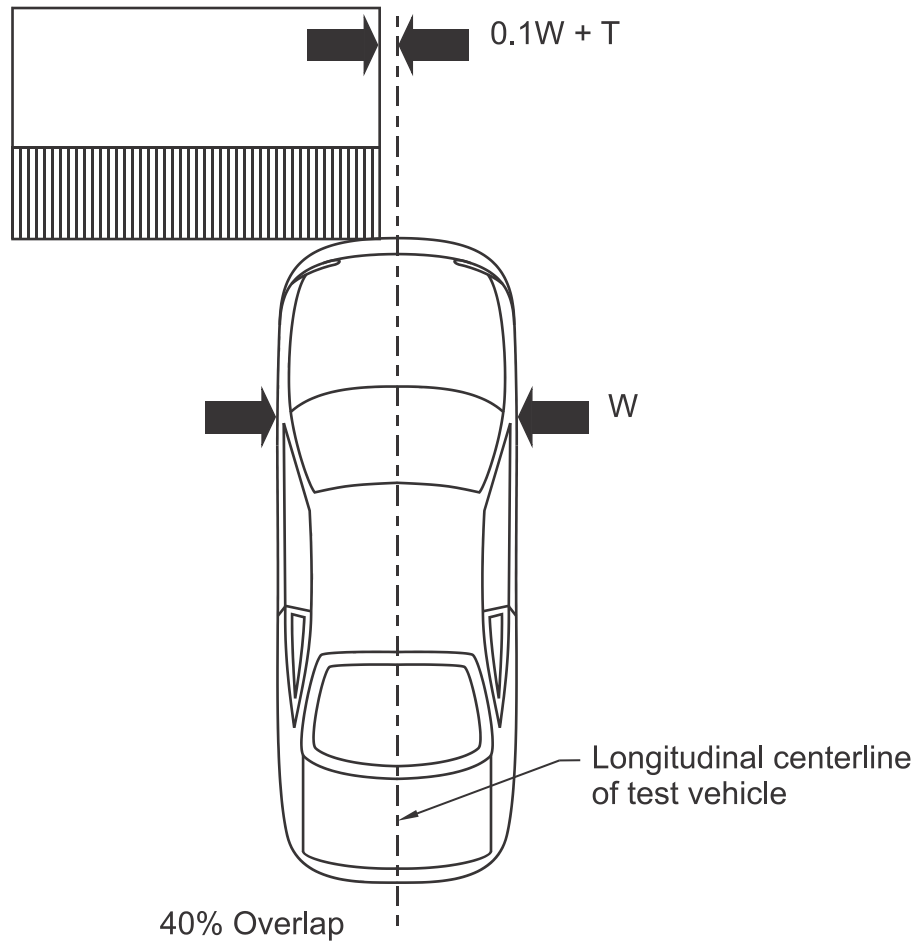

Notes:
W Vehicle Width
T Tolerance

Figure 10. Configuration for Frontal Offset Deformable Barrier Test

Figure 11. [CONTENT NOT REPRODUCED]

Figure 12. [CONTENT NOT REPRODUCED]

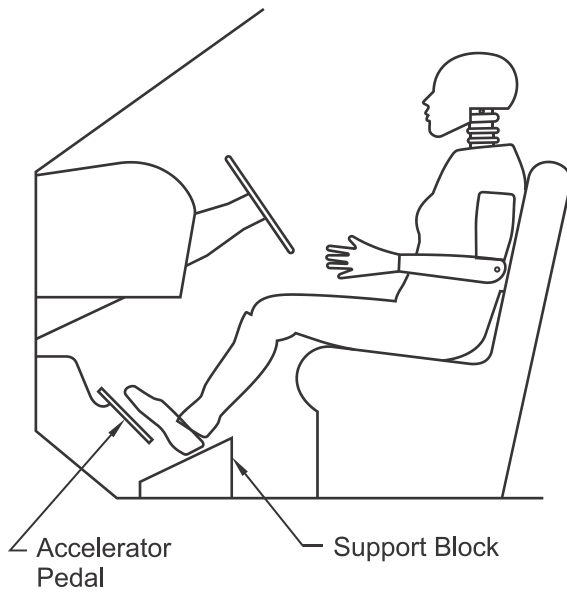

**5th Percentile Female
Right Foot Support Block**

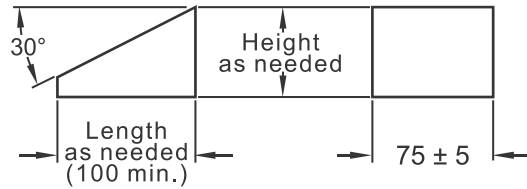

Support Block Detail

- Notes:
1. Dimensions in mm
 2. Drawing not to scale

Figure 13 5th Percentile Female Right Foot Support Block

Appendix A to ~~TSD 208 571.208~~—Selection of Child Restraint Systems

This appendix A applies to vehicles manufactured before September 1, 2009 and to not more than 50 percent of a manufacturer's vehicles manufactured on or after September 1, 2009 and before September 1, 2010, as specified in S14.8 of this ~~TSD standard~~. This appendix does not apply to vehicles manufactured on or after September 1, 2010.

A. The following car bed, manufactured on or after December 1, 1999, may be used by ~~Transport Canada the National Highway Traffic Safety Administration~~ to test the suppression system of a vehicle that has been certified as being in compliance with ~~TSD 208 49-CFR 571.208~~ S19:

Subpart A—Car Bed Child Restraints of Appendix A

Cosco Dream Ride 02–719.

B. Any of the following rear-facing child restraint systems specified in the table below, manufactured on or after December 1, 1999, may be used by ~~Transport Canada the National Highway Traffic Safety Administration~~ to test the suppression or low risk deployment (LRD) system of a vehicle that has been certified as being in compliance with ~~TSD 208 49-CFR 571.208~~ S19. When the restraint system comes equipped with a removable base, the test may be run either with the base attached or without the base.

Subpart B—Rear-Facing Child Restraints of Appendix A

Britax Handle with Care 191.

Century Assura 4553.

Century Smart Fit 4543.

Cosco Arriva 02727.

Evenflo Discovery Adjust Right 212.

Evenflo First Choice 204.

Graco Infant 8457.

C. Any of the following forward-facing child restraint systems, and forward-facing child restraint systems that also convert to rear-facing, manufactured on or after December 1, 1999, may be used by ~~Transport Canada the National Highway Traffic Safety Administration~~ to test the suppression or LRD system of a vehicle that has been certified as being in compliance with ~~TSD 208 49-CFR 571.208~~ S19, or S21. (Note: Any child restraint listed in this subpart that does not have manufacturer instructions for using it in a rear-facing position is excluded from use in testing in a belted rear-facing configuration under S20.2.1.1(a) and S20.4.2):

Subpart C—Forward-Facing and Convertible Child Restraints of Appendix A

Century Encore 4612.
Cosco Olympian 02803.
Britax Roundabout 161.
Century STE 1000 4416.
Cosco Touriva 02519.
Evenflo Horizon V 425.
Evenflo Medallion 254.
Safety 1st Comfort Ride 22–400.

D. Any of the following forward-facing child restraint systems and ~~booster belt positioning~~ seats, manufactured on or after December 1, 1999, may be used by ~~Transport Canada the National Highway Traffic Safety Administration~~ as test devices to test the suppression system of a vehicle that has been certified as being in compliance with ~~TSD 208 49 CFR 571.208~~ S21 or S23:

Subpart D—Forward-Facing Child Restraints and Booster Belt Positioning Seats of Appendix A

Britax Roadster 9004.
Century Next Step 4920.
Cosco High Back Booster 02–442.
Evenflo Right Fit 245.

APPENDIX A–1 TO ~~TSD 208 §571.208~~—SELECTION OF CHILD RESTRAINT SYSTEMS

This Appendix A–1 applies to not less than 50 percent of a manufacturer's vehicles manufactured on or after September 1, 2009 and before September 1, 2010, as specified in S14.8 of ~~TSD 208 this standard~~. This appendix applies to all vehicles manufactured on or after September 1, 2010.

A. The following car bed, manufactured on or after the date listed, may be used by ~~Transport Canada the National Highway Traffic Safety Administration~~ to test the suppression system of a vehicle that has been certified as being in compliance with ~~TSD 208 49 CFR 571.208~~ S19:

Subpart A—Car Bed Child Restraints of Appendix A-1

	Manufactured on or after
Angel Guard Angel Ride XX2403XXX	September 25, 2007.

B. Any of the following rear-facing child restraint systems specified in the table below, manufactured on or after the date listed, may be used by Transport Canada ~~the National Highway Traffic Safety Administration~~ to test the suppression or low risk deployment (LRD) system of a vehicle that has been certified as being in compliance with TSD 208 49 CFR 571.208 S19. When the restraint system comes equipped with a removable base, the test may be run either with the base attached or without the base.

Subpart B—Rear-Facing Child Restraints of Appendix A-1

	Manufactured on or after
Century Smart Fit 4543	December 1, 1999.
Cosco Arriva 22-013 PAW and base 22-999 WHO	September 25, 2007.
Evenflo Discovery Adjust Right 212	December 1, 1999.
Graco Infant 8457	December 1, 1999.
Graco Snugride	September 25, 2007.
Peg Perego Primo Viaggio SIP IMUN00US	September 25, 2007.

C. Any of the following forward-facing child restraint systems, and forward-facing child restraint systems that also convert to rear-facing, manufactured on or after the date listed, may be used by Transport Canada ~~the National Highway Traffic Safety Administration~~ to test the suppression or LRD system of a vehicle that has been certified as being in compliance with TSD 208 49 CFR 571.208 S19, or S21. (Note: Any child restraint listed in this subpart that does not have manufacturer instructions for using it in a rear-facing position is excluded from use in testing in a belted rear-facing configuration under S20.2.1.1(a) and S20.4.2):

Subpart C—Forward-Facing and Convertible Child Restraints of Appendix A–1

	Manufactured on or after
Britax Roundabout E9L02xx	September 25, 2007.
Graco ComfortSport	September 25, 2007.
Cosco Touriva 02519	December 1, 1999.
Evenflo Tribute V 379xxxx or Evenflo Tribute 381xxxx	September 25, 2007.
Evenflo Medallion 254	December 1, 1999.
Cosco Summit Deluxe High Back Booster 22–262	September 25, 2007.
Evenflo Generations 352xxxx	September 25, 2007.
Graco Toddler SafeSeat Step 2	September 25, 2007.
Graco Platinum Cargo	September 25, 2007.
Cosco High Back Booster 22–209	September 25, 2007.

D. Any of the following forward-facing child restraint systems and ~~booster belt positioning~~ seats, manufactured on or after the date listed, may be used by ~~Transport Canada the National Highway Traffic Safety Administration~~ as test devices to test the suppression system of a vehicle that has been certified as being in compliance with ~~TSD 208 49 CFR 571.208~~ S21 or S23:

Subpart D—Forward-Facing Child Restraints and Booster Belt Positioning Seats of Appendix A-1

	Manufactured on or after
Britax Roadster 9004	December 1, 1999.
Graco Platinum Cargo	September 25, 2007.
Cosco High Back Booster 22–209	September 25, 2007.
Evenflo Right Fit 245	December 1, 1999.
Evenflo Generations 352xxxx	September 25, 2007.
Cosco Summit Deluxe High Back Booster 22–262	September 25, 2007.

**Figure A1 to Appendix A and Appendix A-1 of TSD 208 FMVSS No. 208 Regulatory Text:
Loading Bar Foot Detail**

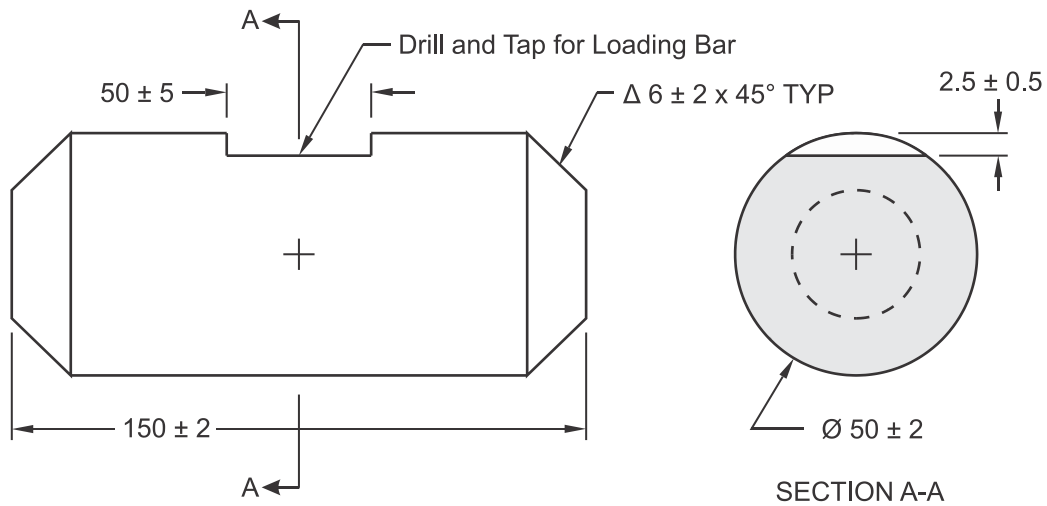

Notes:

1. Dimensions in mm
2. Drawing not to scale
3. Surface Finish: 64 (all surfaces)

Figure A2 to Appendix A and Appendix A-1 of ~~TSD 208 FMVSS No. 208~~ Regulatory Text:
Loading Bar Installation

