



**Transport
Canada**
Motor Vehicle
Safety

**Transports
Canada**
Sécurité des
véhicules
automobiles

TEST METHOD 216

Roof Intrusion Protection

**Revised:
Issued:**

**September 15, 2000R
November 9, 1993**

(Ce document est aussi disponible en français)

Table of Contents

1. Introduction	1
2. Definitions	1
3. Test Procedure	1
3.1 Applicability	1
3.2 General Requirements	1
3.3 Vehicle Set-up	1
3.4 Test Device Orientation	1
3.5 Test Device Alignment	1
3.6 Test Device	2
3.7 Application Force	2
3.8 Test Procedure	2
Figure 1 – Force Application Plate Orientation	3

1. Introduction

Test Method 216 — Roof Intrusion Protection (September 15, 2000) is to be used for demonstrating compliance with the requirements of section 216 of Schedule IV to the *Motor Vehicle Safety Regulations*.

2. Definitions

Windshield trim means any moulding, other than rubber moulding and bonding adhesive, that is located over either the windshield glazing, the exterior roof surface or both.

3. Test Procedure

3.1 Applicability

The following procedure applies in determining compliance with section 216 of Schedule IV to the *Motor Vehicle Safety Regulations*.

3.2 General Requirements

A particular vehicle need not be subjected to further testing after being tested at one location.

3.3 Vehicle Set-up

Prepare the vehicle as follows:

3.3.1 Place the sill or the chassis frame of the vehicle on a rigid horizontal surface and fix the vehicle rigidly in position;

3.3.2 Close all windows, close and lock all doors, and close and secure any removable or opening roof structure in place over the occupant compartment;

3.3.3 Remove all exterior roof racks or similar non-structural components.

3.4 Test Device Orientation

Orient the test device, on either the left or right side of the vehicle's roof structure as shown in Figure 1, so that:

3.4.1 Its longitudinal axis is at a forward angle (side view) of 5° below the horizontal and is parallel to the vertical plane through the vehicle's longitudinal centreline;

3.4.2 Its transverse axis is at an outboard angle, in the front-view projection, of 25° below the horizontal.

3.5 Test Device Alignment

Maintaining the orientation specified in 3.4, align and position the test device as follows:

3.5.1 The longitudinal centreline on its lower surface is on the initial point of contact, or on the centre of the initial contact area, with the roof; and,

3.5.2 The midpoint of the forward edge of the lower surface of the test device is within 10 mm of the transverse vertical plane 254 mm forward of the forward most point on the exterior surface of the roof, including windshield trim, that lies in the longitudinal vertical plane passing through the vehicle's longitudinal centreline.

3.6 Test Device

The plate applying the force to the roof will be a rigid and unyielding block having a lower surface which is a flat rectangle whose dimensions are 762 mm x 1829 mm.

3.7 Application Force

The minimum application force shall be:

3.7.1 For passenger cars 1 1/2 times the unloaded vehicle weight of the tested vehicle or 22,240 newtons, whichever is less; or

3.7.2 For multipurpose passenger vehicles, trucks and buses, 1 1/2 times the unloaded vehicle weight of the vehicle tested.

3.8 Test Procedure

Complete the test as follows:

3.8.1 Apply the force in a downward direction perpendicular to the lower surface of the test device at a rate of not more than 13 mm per-second until reaching the force specified in 3.7;

3.8.2 The force specified in 3.7 must be applied within 120 seconds;

3.8.3 Guide the test device so that throughout the test it moves, without rotation, in a straight line with its lower surface oriented as specified in 3.4; and,

3.8.4 Measure the distance of intrusion that the test device moves, i.e., the distance between the original location of the lower surface of the test device and its location when the force specified 3.7 is reached.

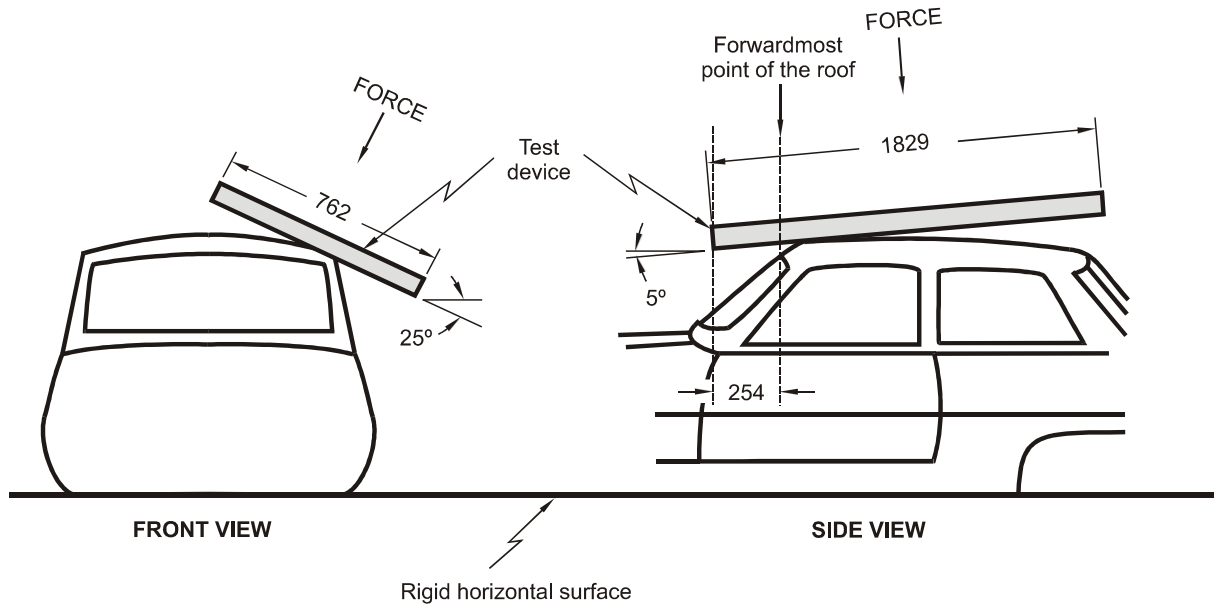

- Notes:
1. Dimensions in mm
2. Drawing not to scale

Figure 1 – Force Application Plate Orientation